



US012236738B2

(12) **United States Patent**
Haishima

(10) **Patent No.:** **US 12,236,738 B2**
(45) **Date of Patent:** **Feb. 25, 2025**

- (54) **MANAGEMENT SERVER**
- (71) Applicant: **Universal Entertainment Corporation**, Tokyo (JP)
- (72) Inventor: **Jun Haishima**, Tokyo (JP)
- (73) Assignee: **UNIVERSAL ENTERTAINMENT CORPORATION**, Tokyo (JP)
- (*) Notice: Subject to any disclaimer, the term of this patent is extended or adjusted under 35 U.S.C. 154(b) by 303 days.

- (21) Appl. No.: **17/428,192**
- (22) PCT Filed: **Jan. 30, 2020**
- (86) PCT No.: **PCT/JP2020/003393**
§ 371 (c)(1),
(2) Date: **Aug. 3, 2021**
- (87) PCT Pub. No.: **WO2020/162312**
PCT Pub. Date: **Aug. 13, 2020**

- (65) **Prior Publication Data**
US 2022/0122403 A1 Apr. 21, 2022

- (30) **Foreign Application Priority Data**
Feb. 4, 2019 (JP) 2019 018016

- (51) **Int. Cl.**
G07D 11/22 (2019.01)
G07F 17/32 (2006.01)
G07D 7/12 (2016.01)
- (52) **U.S. Cl.**
CPC **G07D 11/22** (2019.01); **G07F 17/3246** (2013.01); **G07D 7/12** (2013.01); **G07D 2207/00** (2013.01); **G07D 2211/00** (2013.01)

- (58) **Field of Classification Search**
CPC .. G07D 11/22; G07D 2211/00; G07F 17/3246
See application file for complete search history.

- (56) **References Cited**
U.S. PATENT DOCUMENTS
8,641,513 B2 * 2/2014 Brosnan G07F 17/32 463/16
9,501,897 B2 * 11/2016 Hafezi G07F 17/323
(Continued)

- FOREIGN PATENT DOCUMENTS
JP 2013-127805 6/2013
WO 2010055726 5/2010
Primary Examiner — Seng H Lim
(74) *Attorney, Agent, or Firm* — Simpson & Simpson, PLLC; S. Peter Konzel

(57) **ABSTRACT**
An object of the present invention is to provide a management server which makes it possible to set areas in which a predetermined currency is available and areas in which the predetermined currency is unavailable, in a case in which a lot of currency handling systems in each of which a variety of currencies are available are used. A slot machine management server **1** is connected with currency handling systems including a currency reading device **201** in which a variety of currencies are available. Each currency handling system **100** is associated with any of areas A to H. The slot machine management server **1** includes: an input unit **104**; a communication interface **103**; and a center controller **101**, and the center controller **101** sends a command of causing a process of allowing usage of the selected currency to be performed in a case in which the center controller **101** receives a selection of an area and a selection of a currency, a currency read in the currency reading device **201** corresponds to the selected currency, and the currency reading device **201** that read the currency corresponds to the selected area.

7 Claims, 16 Drawing Sheets

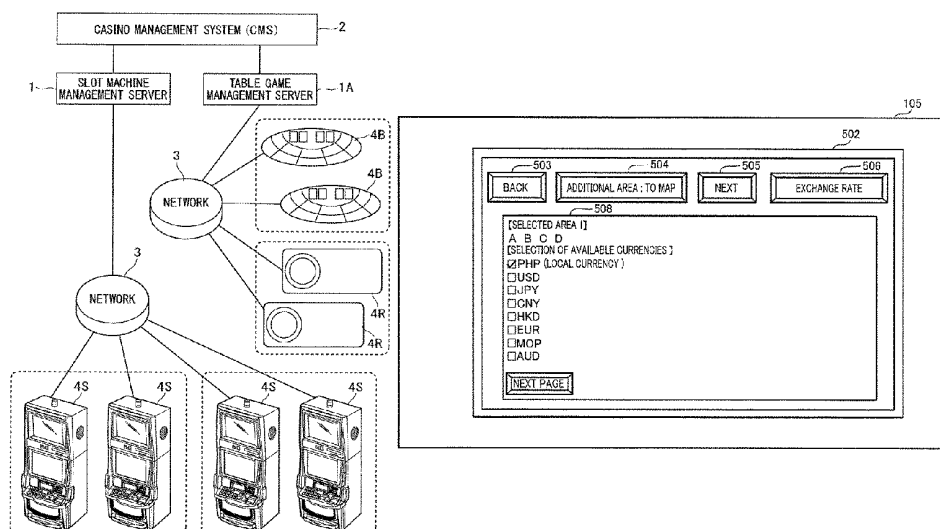

(56)

References Cited

U.S. PATENT DOCUMENTS

9,536,387 B2* 1/2017 Doyle G07F 17/3246
 10,885,742 B2* 1/2021 Emori G07F 17/3246
 11,227,467 B2* 1/2022 Emori G07F 17/3227
 11,328,563 B1* 5/2022 Fraser G07F 19/205
 2002/0138594 A1* 9/2002 Rowe G07F 17/32
 709/219
 2003/0081824 A1* 5/2003 Mennie G07D 7/06
 382/135
 2003/0216182 A1* 11/2003 Gauselmann G07F 17/323
 463/40
 2005/0037837 A1* 2/2005 Rowe G07F 17/32
 463/25
 2007/0032288 A1* 2/2007 Nelson G07F 17/323
 463/16
 2007/0155490 A1* 7/2007 Phillips G07F 17/32
 463/29
 2007/0173328 A1* 7/2007 Edgren G07F 17/323
 463/42
 2008/0120232 A1* 5/2008 Herrin G07D 11/30
 235/487
 2009/0012823 A1* 1/2009 Anderson G06Q 10/06
 707/999.001
 2009/0063344 A1* 3/2009 Travis G06Q 20/381
 705/43

2009/0124370 A1* 5/2009 Walkwitz G07F 17/3244
 463/27
 2009/0276715 A1* 11/2009 Arbogast H04L 67/06
 715/736
 2011/0195786 A1* 8/2011 Wells G07F 9/026
 463/47
 2011/0212762 A1* 9/2011 Ocko A63F 13/85
 463/25
 2011/0270425 A1* 11/2011 Kelly G07F 17/3239
 700/92
 2012/0135799 A1* 5/2012 Okada G07F 17/3202
 463/25
 2012/0252556 A1* 10/2012 Doyle G07F 17/3246
 463/25
 2013/0344945 A1* 12/2013 Hafezi G07F 17/3262
 463/25
 2015/0038217 A1* 2/2015 Okada G07D 11/16
 463/25
 2017/0287256 A1* 10/2017 Takeda B65H 43/04
 2019/0156626 A1* 5/2019 Emori G07F 17/3211
 2020/0312074 A1* 10/2020 Jagielinski G06V 20/66
 453/4
 2022/0122063 A1* 4/2022 Haishima G07D 11/22
 2022/0130209 A1* 4/2022 Haishima G07F 17/3223

* cited by examiner

FIG. 1

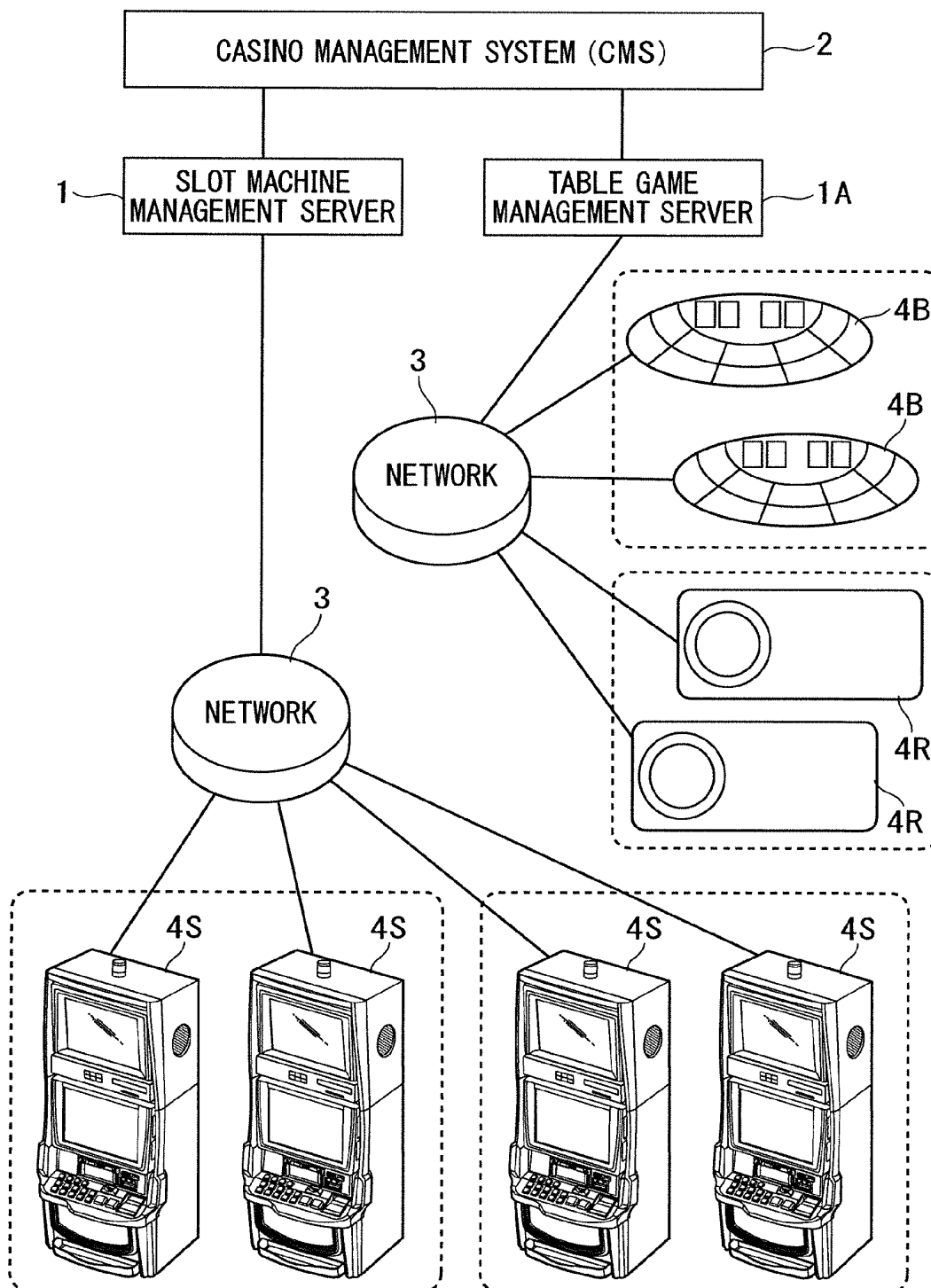

FIG. 2

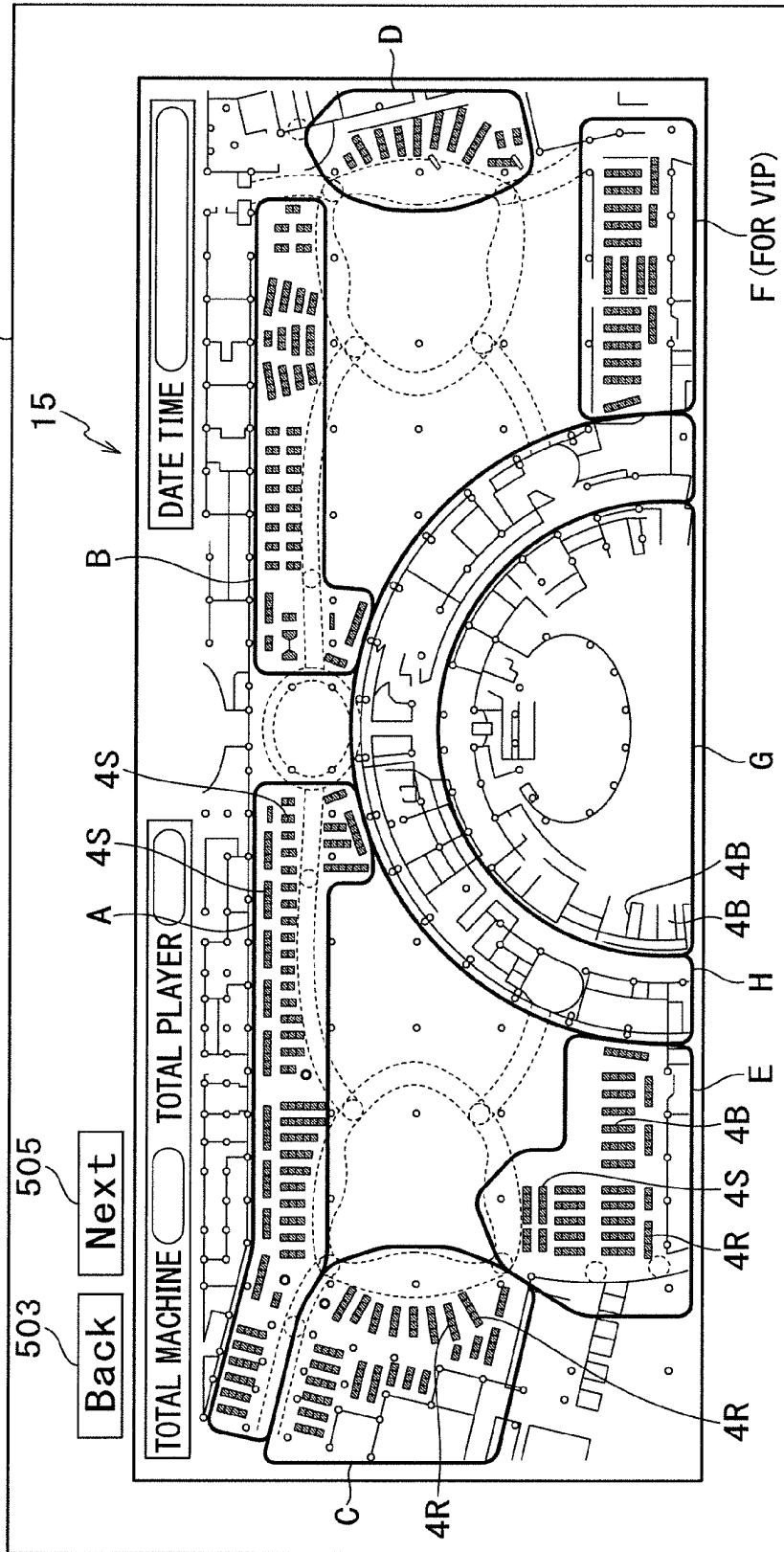

FIG.3

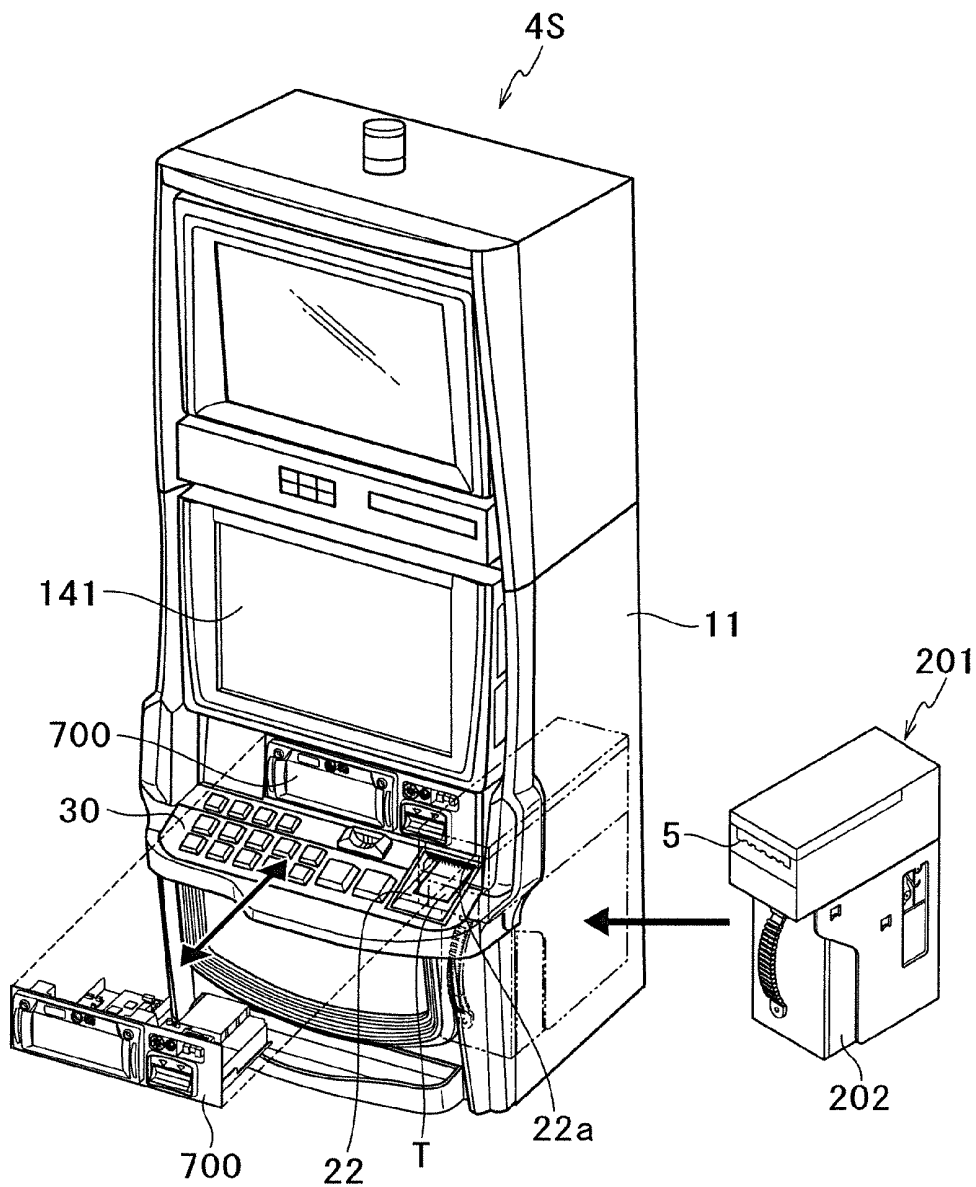

FIG. 4

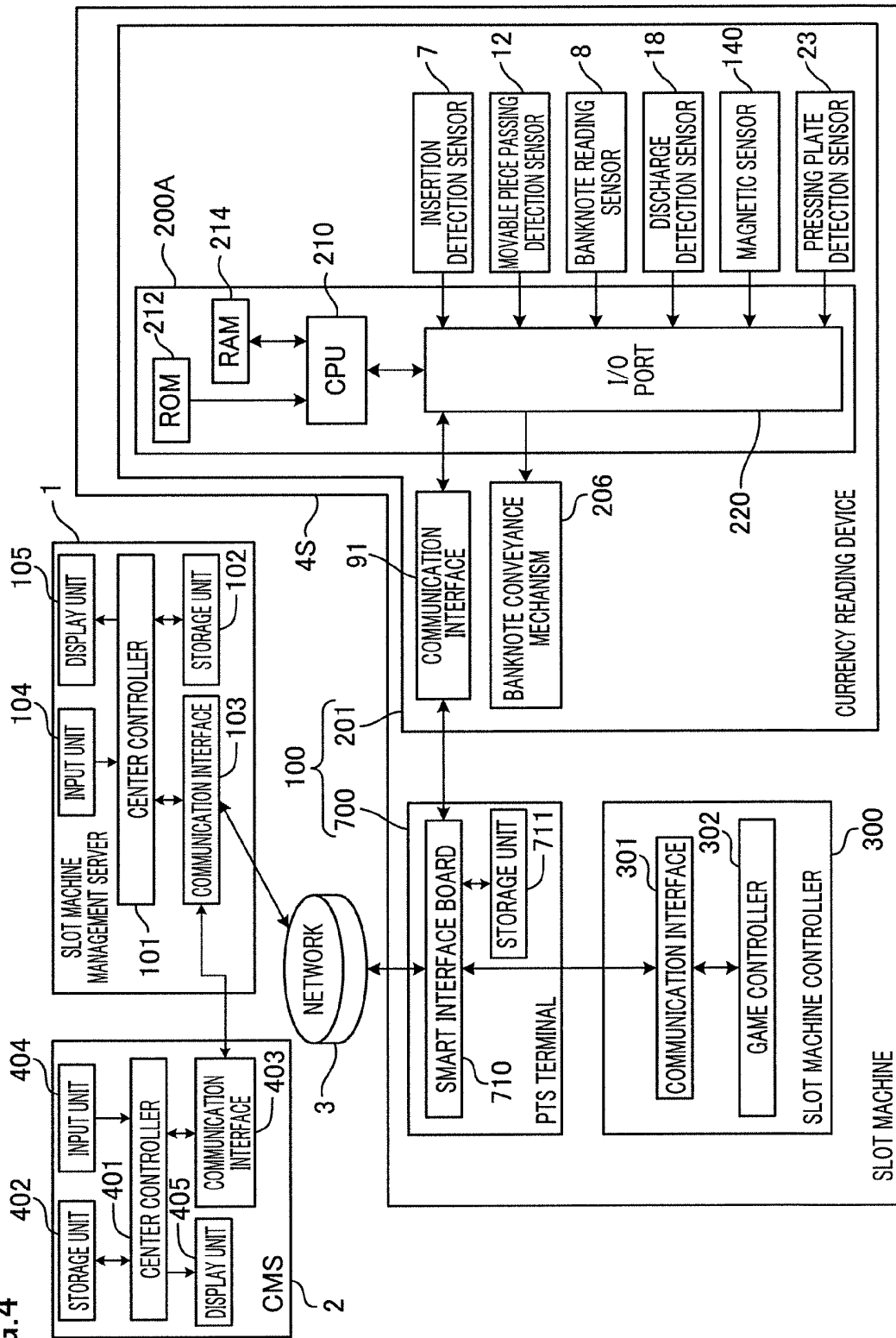

FIG.5

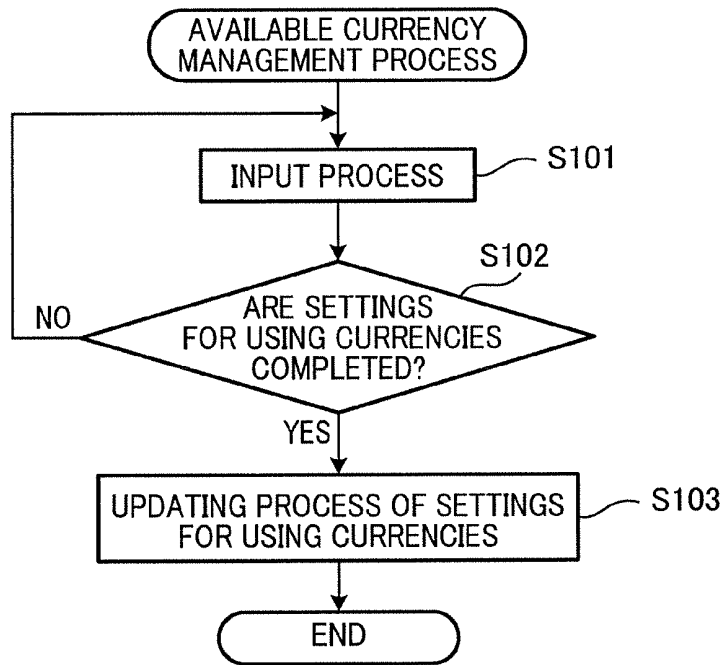

FIG.6

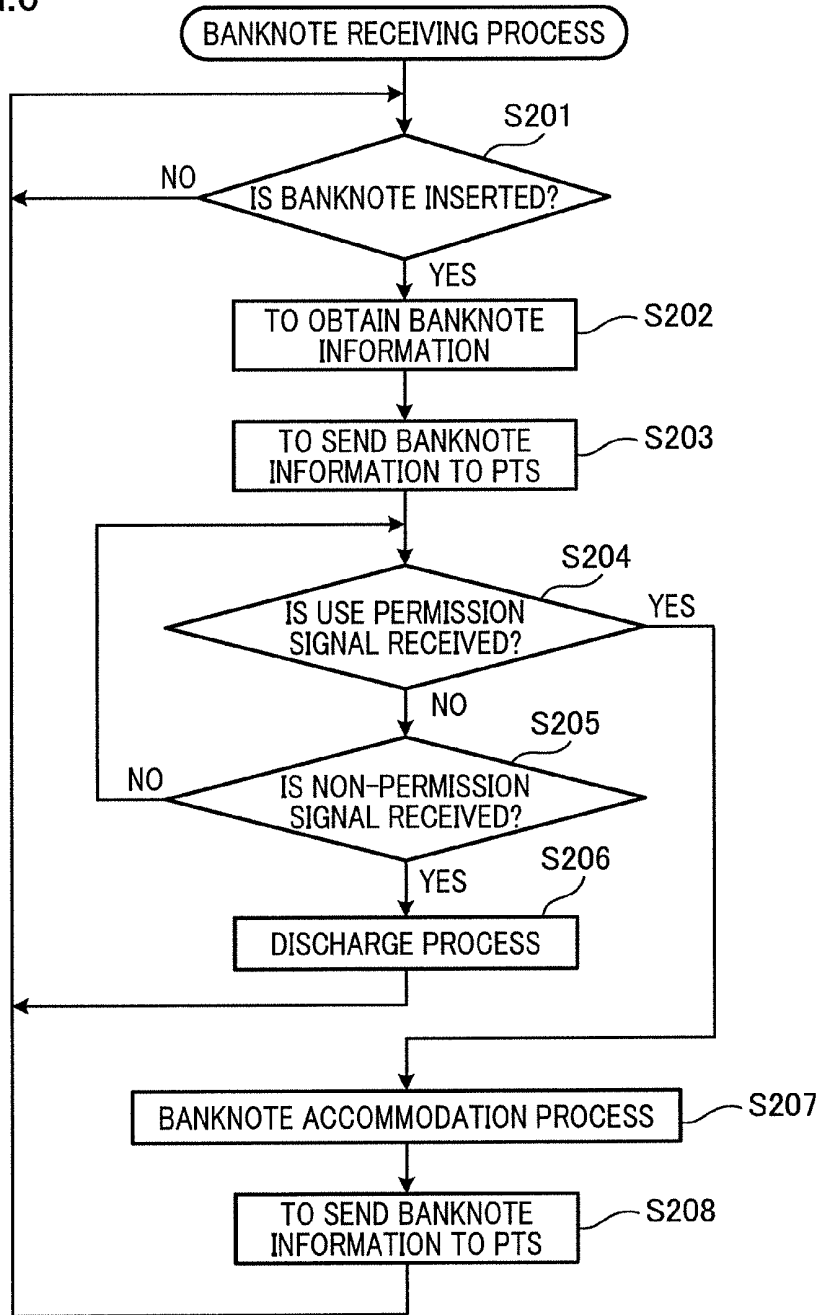

FIG.7

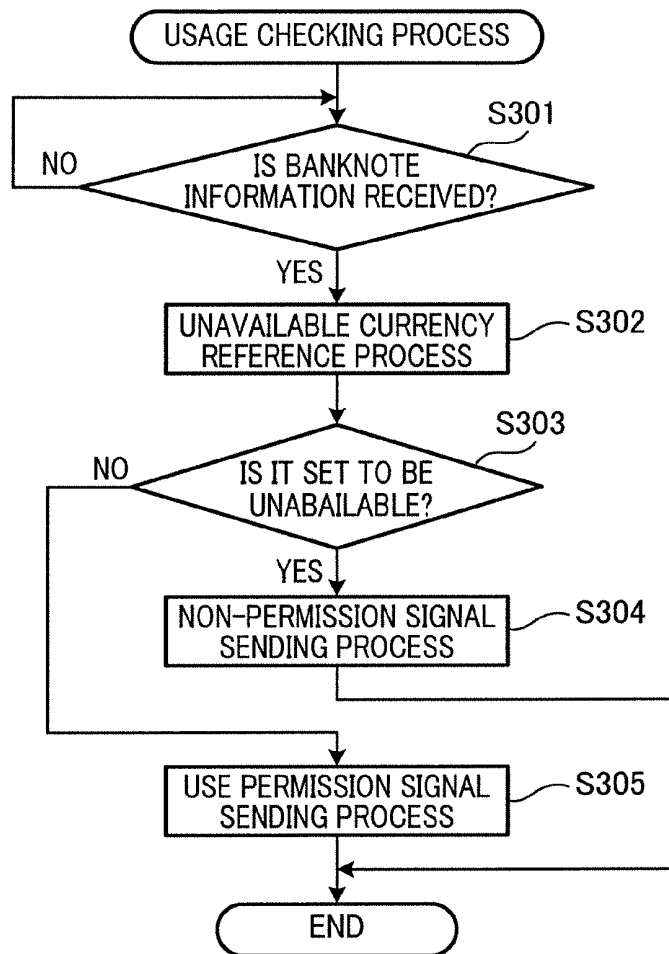

FIG.8

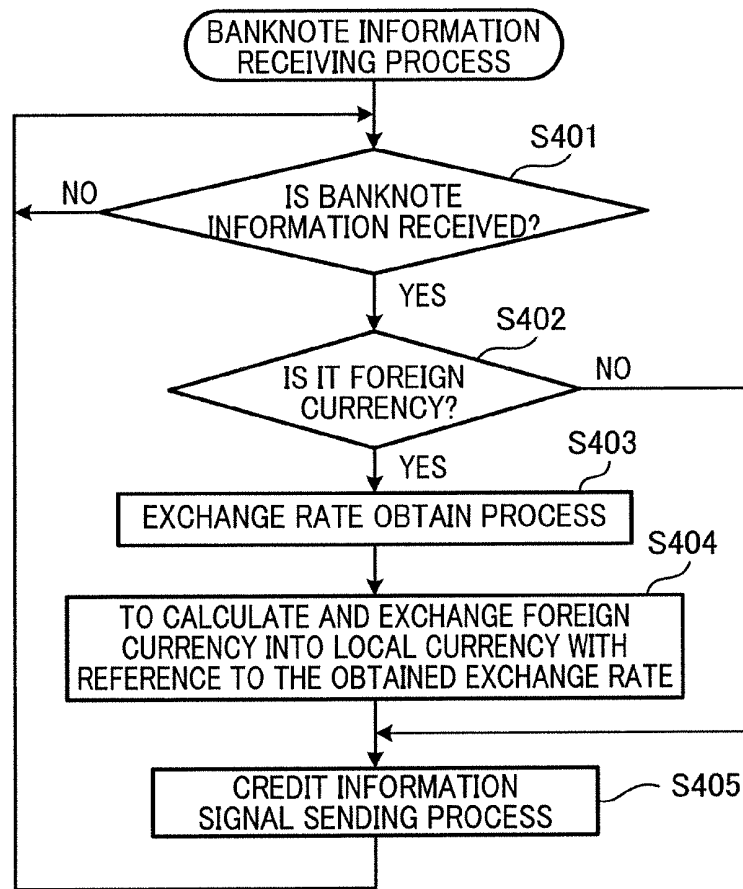
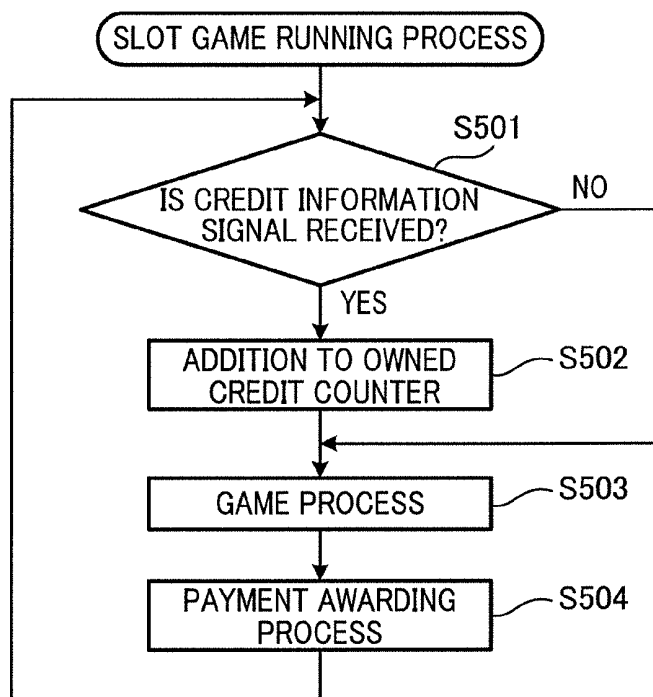

FIG.9



105

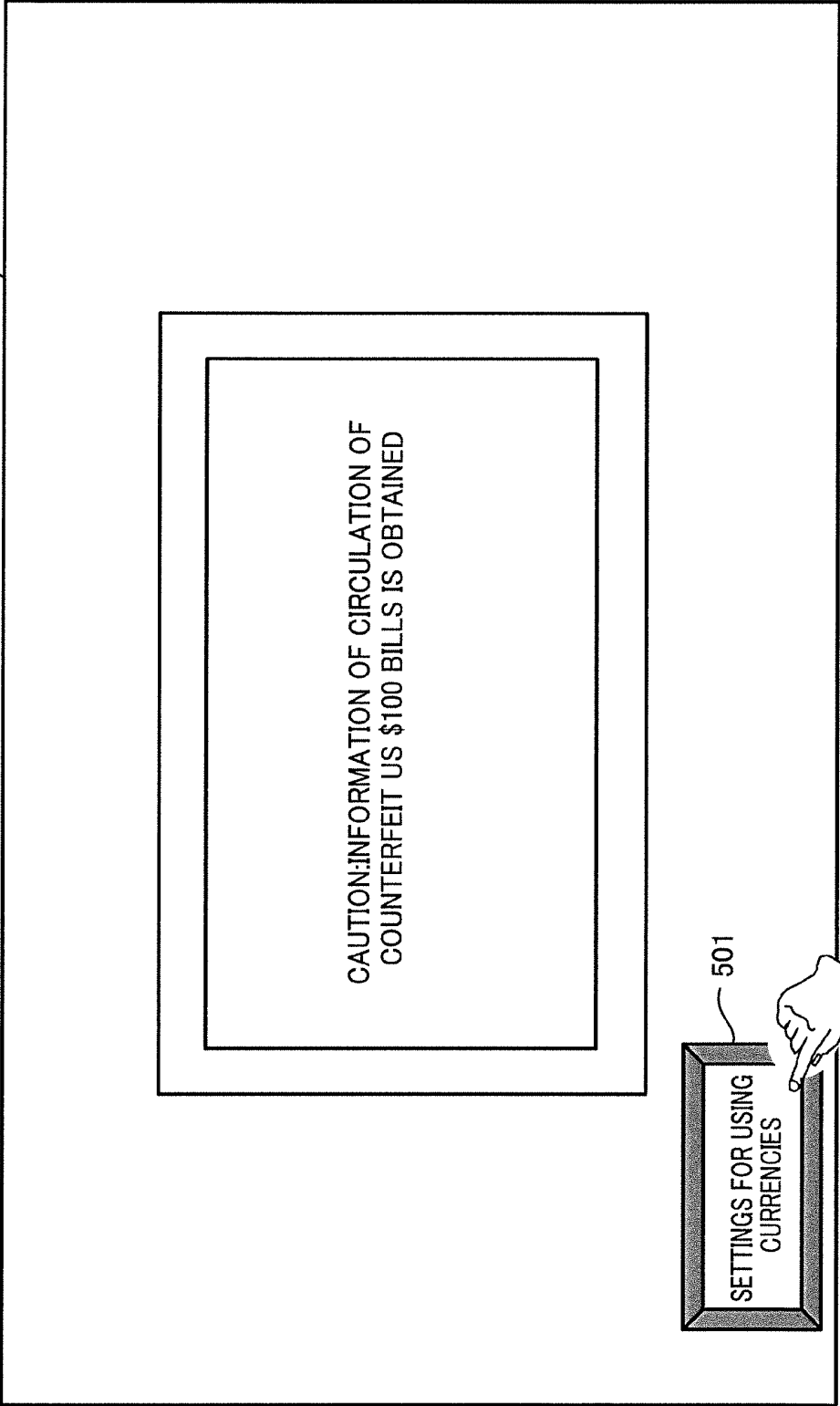
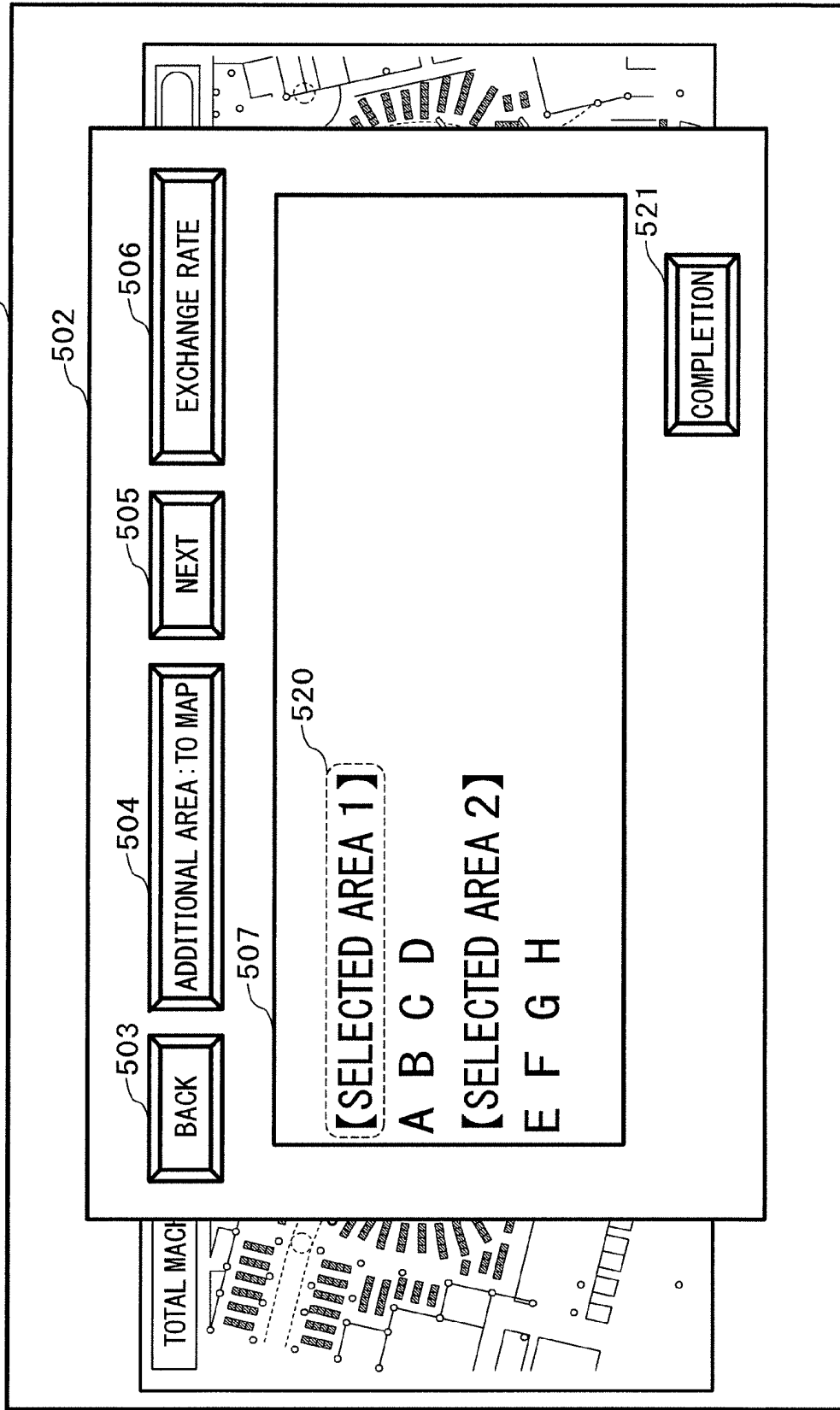

FIG.10

FIG. 11



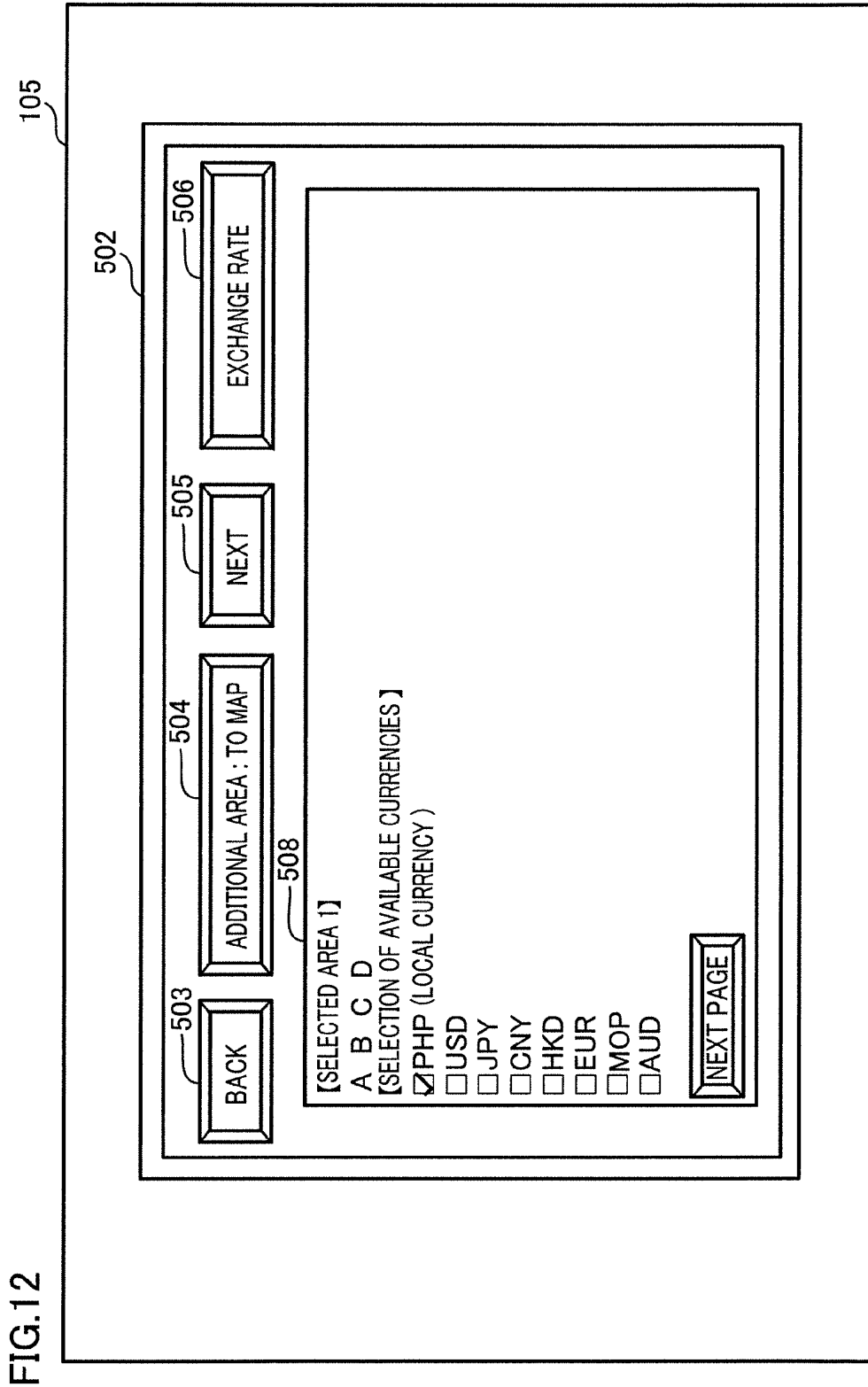
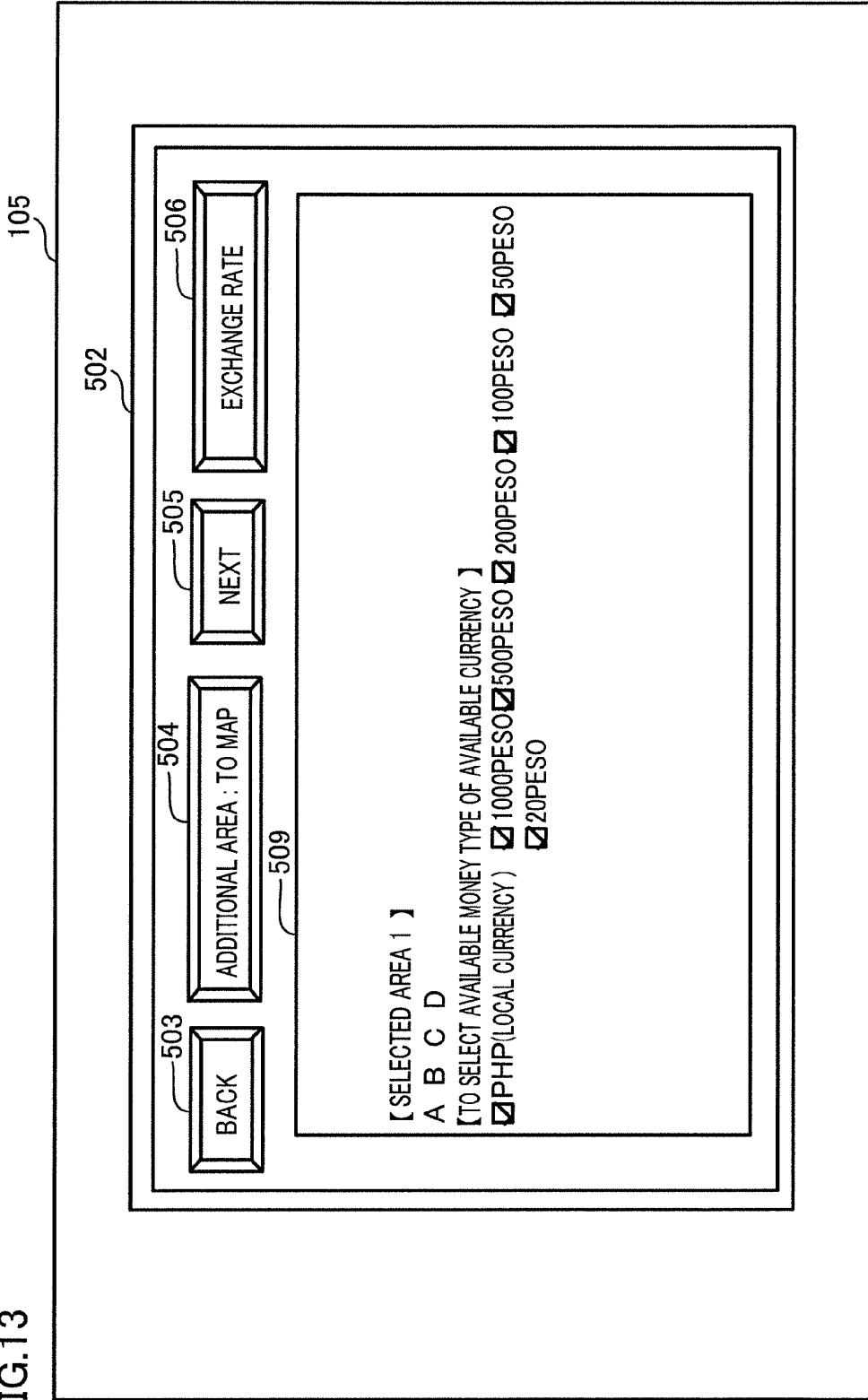

FIG.13



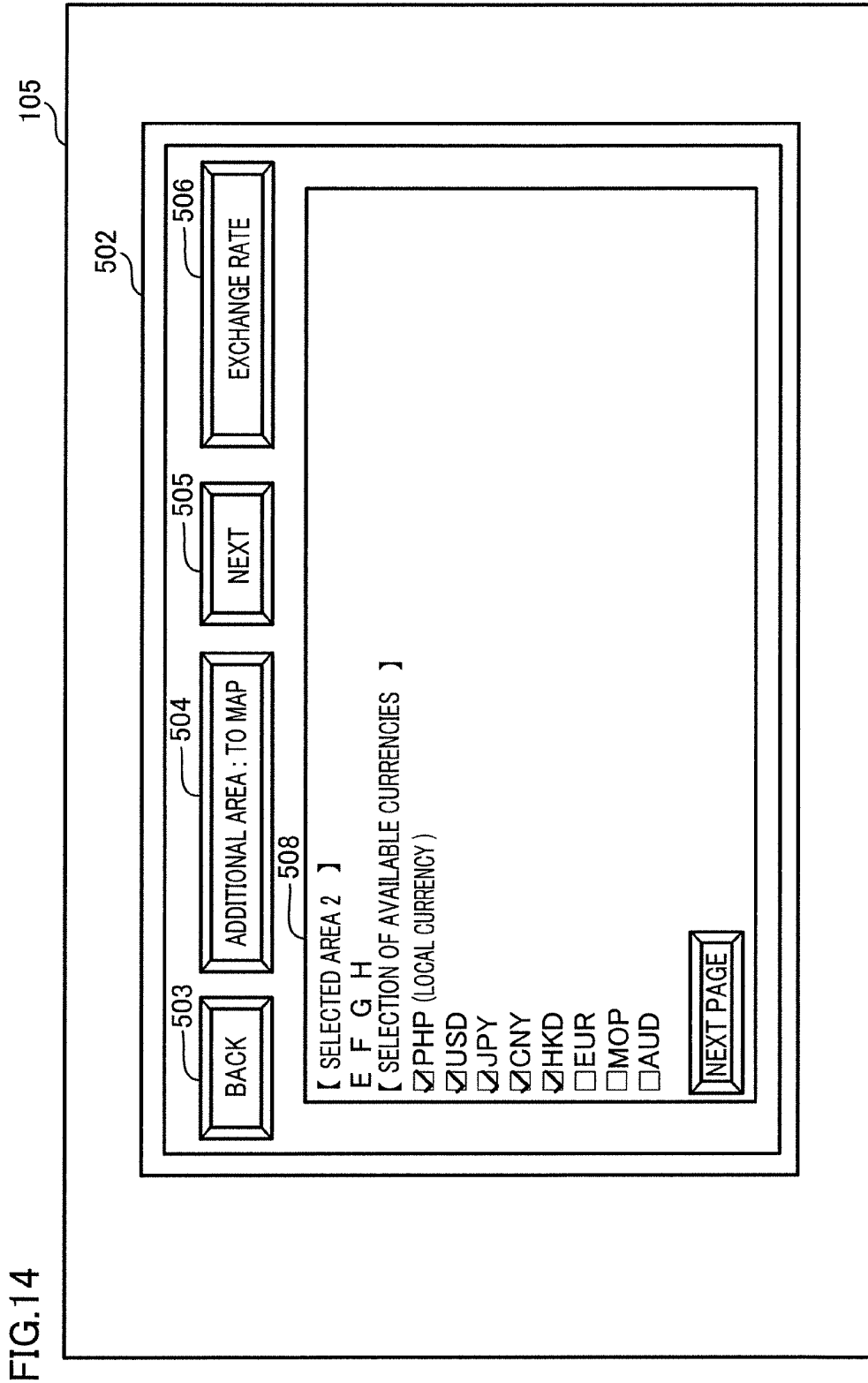

FIG.15

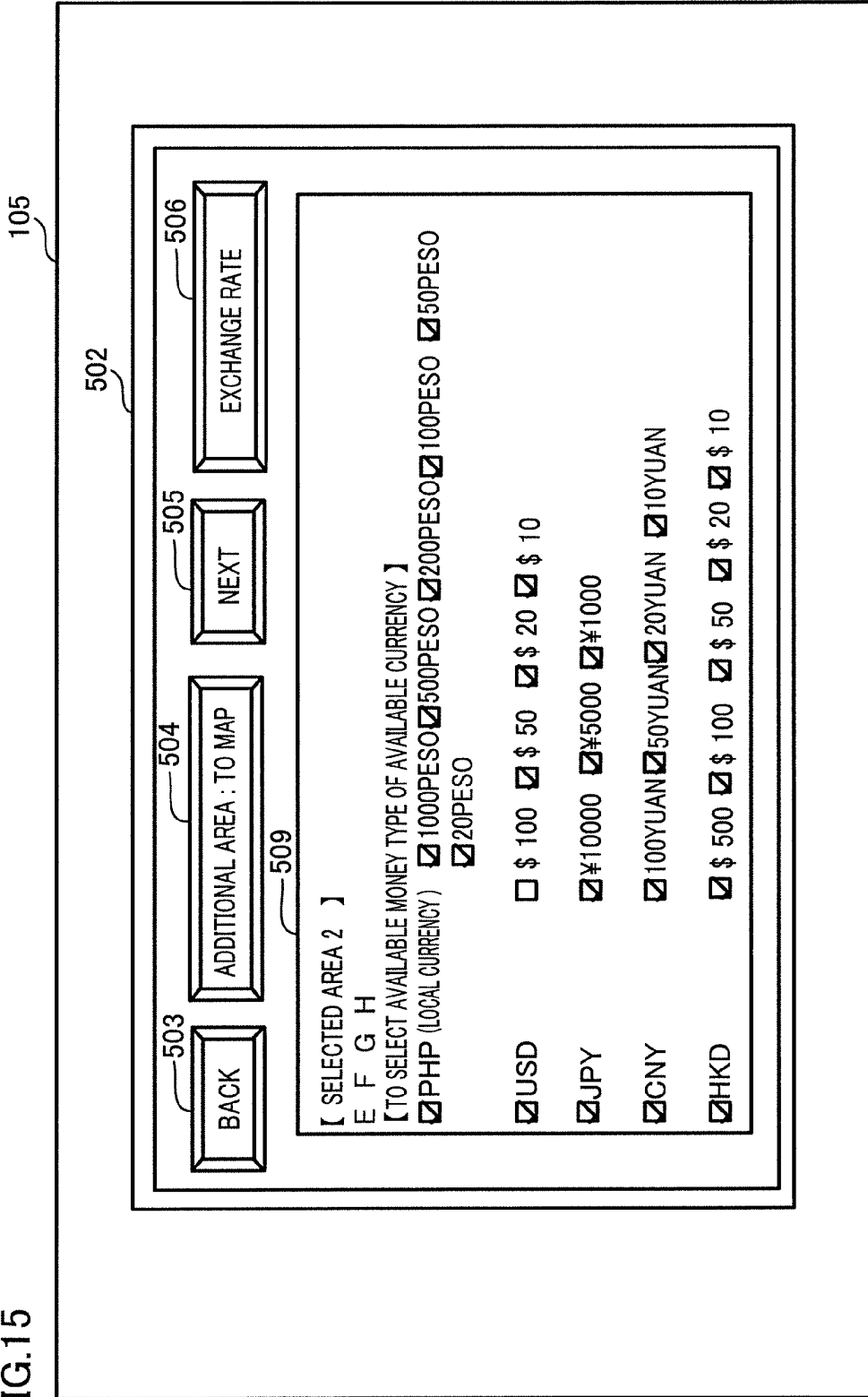
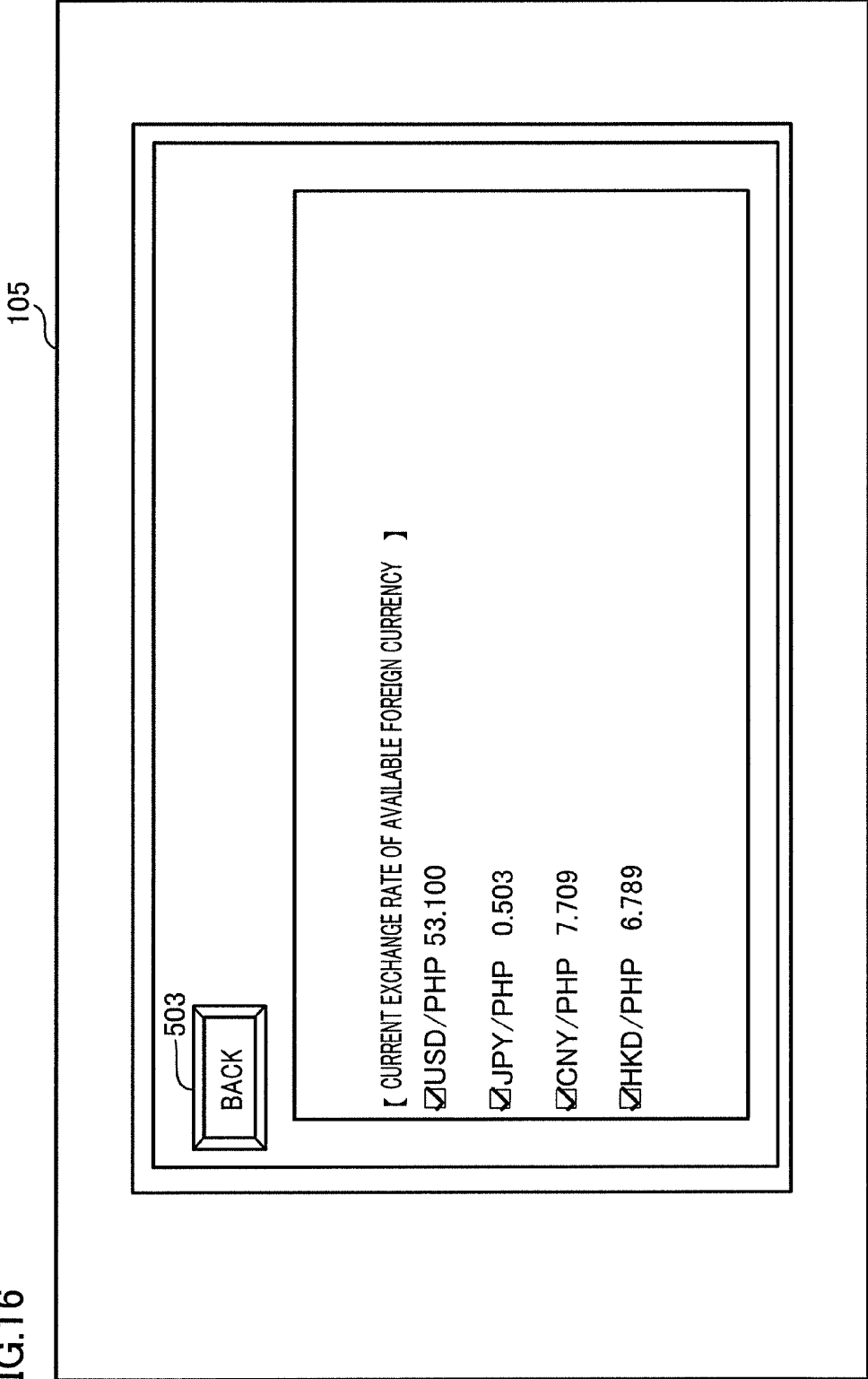

FIG.16



MANAGEMENT SERVER

TECHNICAL FIELD

The present invention relates to a management server which manages currency handling systems each of which includes a currency reading device in which a variety of currencies are available.

BACKGROUND ART

A known currency reading device (Bill Validator) provided at a gaming machine receives only currency of the country in which the gaming machine is provided, and is able to distinguish the face value (see Patent Literatures 1 to 2).

However, with increase of travelers and sojourners from foreign countries, gaming machines are increasingly required to accept foreign currencies. As such, gaming machines are required to accept foreign currencies.

CITATION LIST

Patent Literatures

[PTL 1] Japanese Unexamined Patent Publication No. 2013-127805

[PTL 2] Japanese Unexamined Patent Publication No. 2012-141897

SUMMARY OF INVENTION

Technical Problem

However, when a variety of currencies are available, it makes management and maintenance laborious to accept a variety of currencies in all gaming machines. In addition to that, a season in which the number of players is large (because of, e.g., difference of holidays between countries) and a time period at which the number of staying players is large in a day are not constant. Therefore, in some cases it is required to change the areas of gaming machines in which foreign currencies are available and the number of gaming machines, between seasons or times of a day.

An object of the present invention is to provide a management server which solves the above-described problems.

Solution to Problem

The present invention is a management server which is connected, through a communication line, to currency handling systems each including a currency reading device in which a variety of currencies are available, each of the currency handling systems being associated with any of areas,

the management server includes:

an input unit which allows selection of an area from among the areas and a currency from among the variety of the currencies;

a transmitter which is configured to send a command to the currency handling systems; and

a controller which is programmed to perform processes of: (a) receiving a selection of an area from among the areas and a selection of a currency from among the variety of the currencies, by the input unit; and

(b) sending a command of causing a process of allowing usage of the selected currency to be performed from the

transmitter to one currency handling system, in a case in which a currency read by the currency reading device corresponds to the selected currency and the currency reading device that read the currency corresponds to the selected area.

By the above-described structure, when a lot of currency handling systems in each of which a variety of currencies are available are used, it is possible to freely set areas in which a selected currency is available and areas in which the selected currency is unavailable.

The present invention is the management server, and the input unit further allows selection of a money type from among a variety of money types, and, the controller is programmed to perform processes of:

(a) receiving a selection of an area from among the areas, a selection of a currency from among the variety of the currencies, and a selection of a money type from among the variety of the money types, by the input unit; and

(b) sending a command of causing a process of allowing usage of the selected money type of the selected currency to be performed from the transmitter to one currency handling system, in a case in which a currency read in the currency reading device corresponds to the selected money type of the selected currency and the currency reading device that read the currency corresponds to the selected area.

By the above-described structure, when a lot of currency handling systems in each of which a variety of currencies are available are used, it is possible to freely set areas in which a selected money type of a selected currency is available and areas in which the selected money type of the selected currency is unavailable.

The present invention is the management server, each of the currency handling systems is mounted in a gaming machine which awards a payout based on a game result and a bet of a currency, and the areas are distinguished from one another based on the minimum of an amount of a currency which is betted at the gaming machine.

By the above-described structure, because areas are distinguished from one another based on the minimum of an amount of a currency which is betted, it is possible to select both group of areas based on the minimum of the betted amount in a case in which areas in which a predetermined currency is available and the areas in which predetermined currency is unavailable are set.

BRIEF DESCRIPTION OF DRAWINGS

FIG. 1 illustrates a network environment of a casino system.

FIG. 2 illustrates areas A to H which are associated with gaming machines provided at a gaming facility.

FIG. 3 illustrates a currency reading device and a PTS terminal which are provided at a slot machine.

FIG. 4 is a block diagram of a casino management system, a slot machine management server, and a slot machine, etc.

FIG. 5 is a flowchart of an available currency management process.

FIG. 6 is a flowchart of a banknote receiving process.

FIG. 7 is a flowchart of a usage checking process.

FIG. 8 is a flowchart of a banknote information receiving process.

FIG. 9 is a flowchart of a slot game running process.

FIG. 10 is an explanatory diagram showing a state in which counterfeit bill information is displayed on a display unit of the slot machine management server.

FIG. 11 is an explanatory diagram of a status window.

FIG. 12 is an explanatory diagram of an available currency selection screen of a selected area 1.

FIG. 13 is an explanatory diagram of an available money type selection screen of the selected area 1.

FIG. 14 is an explanatory diagram of an available currency selection screen of a selected area 2.

FIG. 15 is an explanatory diagram of an available money type selection screen of the selected area 2.

FIG. 16 is an explanatory diagram of an exchange rate screen.

PREFERRED EMBODIMENT OF INVENTION

Embodiment

The following will describe a casino system including a slot machine management server 1 of the present embodiment with reference to figures. In this regard, the slot machine management server 1 corresponds to a management server of the present invention, and is connected through a communication line with a currency handling system 100 (currency reading device 201 and PTS terminal 700) mounted at a slot machine 4S. (Casino System)

As shown in FIG. 1, the slot machine management server 1 is connected with slot machines 4S (gaming machines 4) through a network 3 (communication lines). In other words, the slot machine management server 1 mainly plays a role of managing the slot machines 4S. The slot machine management server 1 itself is connected with a casino management system 2 (CMS) which manages operation of the entire casino. With the casino management system 2, a table game management server 1A is also connected. The table game management server 1A plays a role of managing table games (total sales, etc.) such as baccarat game tables 4B, roulette game machines 4R, and poker game machines 4P, which correspond to other gaming machines 4. In this regard, the casino management system 2 itself may be connected with the outside through communication lines (the Internet, etc.).

The gaming machine 4 includes a device which is able to perform or support a game (e.g., support of progress of a game and support of calculation of a payout). In the game, a payout may be awarded based on a betted gaming value and a game result. The gaming machine 4 further includes a device which is embedded in or provided to be adjacent to a playing table of baccarat or poker, which is a game controlled by a human player. In this regard, the gaming value is electrically valuable information in which a currency amount is exchanged into electronic money, etc. The gaming value in the disclosure is not limited to this, and for example a gaming medium such as a medal, a token, a coin, or a ticket or the like may be used. The ticket is not particularly limited, and for example, a barcoded ticket may be used. The barcoded ticket has data of, e.g., a credit amount in the form of bar code. Alternatively, the gaming value may be a game point which does not include valuable information.

As shown in FIG. 2, the gaming machines 4 such as the slot machines 4S, baccarat game tables 4B, roulette game machines 4R, and poker game machines 4P are provided at a gaming facility 15. In addition to that, the slot machines 4S managed by the slot machine management server 1 are associated with any of areas A to H in the gaming facility 15.

For example, the area A is provided with slot machines 4S which are of a type Y, in which the minimum bet (the minimum bet amount to start a game) is set to be lower than the minimum bet in the area B. The area B is provided with

the slot machines 4S which are of the type Y, in which the minimum bet is set to be higher than the minimum bet in the area A. The area C is provided with slot machines 4S which are of a type Z, in which the minimum bet is set to be lower than the minimum bet in the area D. The area D is provided with the slot machines 4S which are of the type Z, in which the minimum bet is set to be higher than the minimum bet in the area C. The area E is provided with slot machines 4S, in which the minimum bet is set to be the highest among the minimum bets among the gaming facility 15. The area F is provided with slot machines 4S which are used exclusively for VIP members. The area G is provided with slot machines 4S which are of a type X, in which the minimum bet is set to be higher than the minimum bet in the area H. The area H is provided with the slot machines 4S which are of the type X, in which the minimum bet is set to be lower than the minimum bet in the area G.

In this regard, it is possible to arrange areas of each gaming facility at will, e.g., which slot machine 4S is associated with each area and for what reason each area is provided. For example, areas may correspond to respective types of games or manufacturers, areas may be classified based on values of minimum bets or based on available currencies, or one area may be associated with one slot machine 4S.

In the present embodiment, the currency reading device 201 is mounted in a slot machine 4S (gaming machine 4) which awards a payout based on a game result and a bet of a gaming value (currency), and areas are distinguished from one another based on the minimum (minimum bet: bet amount necessary to start a single game) of an amount (currency amount) of a gaming value which is betted at the slot machine 4S. Because of this, when areas in which a predetermined currency is available and areas in which the predetermined currency is unavailable are set, both groups of areas are selected based on the minimum bet. (Structure of Slot Machine Management Server 1)

As shown in FIG. 4, the slot machine management server 1 is a computer. The slot machine management server 1 includes a center controller 101, a storage unit 102 which stores information, etc., a communication interface 103 for achieving sending and receiving of a signal (command) to and from the outside, an input unit 104 (touch panel, keyboard, and mouse, etc.) which makes it possible to input information, etc., and a display unit 105 which is able to display characters and images, etc. In this regard, information is sent from the slot machine 4S (PTS terminal 700, etc.) or the casino management system 2, or is input from the input unit. Although not illustrated, the center controller 101 includes a CPU, a ROM, a RAM, and an I/O port to which members such as the storage unit 102, the communication interface 103 (transmitter), the input unit 104, and the display unit 105 are connected.

(Structure of Casino Management System 2)

As shown in FIG. 4, the casino management system 2 is a computer which manages the operation of the entire casino (including management of the exchange rate, etc.). Similarly to the slot machine management server 1, the casino management system 2 includes a center controller 401, a storage unit 402 which stores information, etc., a communication interface 403 for achieving sending and receiving of a signal (command) to and from the outside, an input unit 404 (touch panel, keyboard, and mouse, etc.) which makes it possible to input information, etc., and a display unit 405 which is able to display characters and images, etc. In this regard, information is sent from the slot machine management server 1 or is input from the input unit.

The center controller **401** of the casino management system **2** plays a role of sending information of the exchange rate which is stored in the storage unit **402** to the currency handling system **100** (PTS terminal **700**) in a case in which a banknote T read by the currency reading device **201** is determined as a foreign currency in the PTS terminal **700**. In this casino management system **2**, the exchange rate referred by the entire casino system is managed. This exchange rate is updated by manual input of a person in charge of the casino management system **2** at a predetermined time (AM 6:00).

(Slot Machine 4S)

In the present embodiment, the slot machine **4S** will be described as an example of a gaming machine **4** which is provided with the currency handling system **100** (PTS terminal **700** and currency reading device **201**). A device corresponding to the currency handling system **100** is also mounted at each of, e.g., the baccarat game table **4B**, the roulette game machine **4R**, and the poker game machine **4P** which are managed by the table game management server **1A**.

As shown in FIG. 3, the slot machine **4S** includes a cabinet **11**. In the cabinet **11**, the currency reading device **201**, a slot machine controller **300**, and the PTS terminal **700** are provided. Outside the cabinet **11**, the followings are provided: a game image display panel **141** which displays a game image, etc.; a control panel **30** which is provided with buttons, etc., for operating a game; and a bill entry **22** which includes an insertion slot **22a** for receiving a banknote T from the outside. In other words, a banknote T is received into the currency reading device **201** through the insertion slot **22a** of the bill entry **22**.

(Currency Reading Device 201)

As shown in FIG. 3, the currency reading device **201** is disposed in the cabinet **11** so that a banknote insertion slot **5** is identical to the insertion slot **22a** of the bill entry **22**. In this way, a banknote T inserted from the insertion slot **22a** of the bill entry **22** is introduced into the currency reading device **201**. In addition to that, the currency reading device **201** includes a banknote accommodation unit **202** which accommodates the received banknote T. The banknote accommodation unit **202** has a function as a safe, and is detachably attached to the currency reading device **201**.

In the currency reading device **201** of the present embodiment, not only a banknote T of PHP (peso) but also banknotes T of plural foreign currencies (USD, US dollar; JPY, Japanese yen; CNY, yuan; HKD, Hong Kong dollar; EUR, euro; MOP, Macanese pataca; AUD, Australian dollar) are available. PHP (peso) is set as a local currency.

As shown in FIG. 4, a banknote conveyance mechanism **206** is provided inside the currency reading device **201**. The banknote conveyance mechanism **206** conveys a banknote T which is inserted from the insertion slot **22a** of the bill entry **22**, to the banknote accommodation unit **202**. In addition to that, inside the currency reading device **201**, a control circuit board **200A** which controls motion of a driving device such as the banknote conveyance mechanism **206** is provided. On this control circuit board **200A**, a CPU (Control Processing Unit) **210**, a ROM (Read Only Memory) **212**, a RAM (Random Access Memory) **214**, and an I/O port **220** are mounted.

The CPU **210** receives detection signals, through the I/O port **220**, from sensors such as an insertion detection sensor **7**, a movable piece passing detection sensor **12**, a banknote reading sensor **8**, a discharge detection sensor **18**, a magnetic sensor **140**, and a pressing plate detection sensor **23**. The insertion detection sensor **7** detects a banknote T inserted

into the banknote insertion slot **5**. The movable piece passing detection sensor **12** detects being passed through a predetermined position of the banknote conveyance mechanism **206**. The banknote reading sensor **8** reads information of the banknote T which is being conveyed. The discharge detection sensor **18** detects the banknote T being discharged into the banknote accommodation unit **202**. The magnetic sensor **140** detects whether banknotes T which are laminated and accustomed in the banknote accommodation unit **202** reach a predetermined number. The pressing plate detection sensor **23** can detect a position of a pressing plate which presses banknotes T in the banknote accommodation unit **202**. Based on these detection signals, the drive control of the banknote conveyance mechanism **206**, etc., is performed. To the I/O port **220**, a communication interface **91** is connected. The communication interface **91** is connected to a smart interface board **710** of the PTS terminal **700** so as to enable data communication with the PTS terminal **700**.

The insertion detection sensor **7** generates a detection signal when detecting a banknote T inserted into the banknote insertion slot **5**. While the insertion detection sensor **7** is an optical sensor such as a retro-reflective photo sensor, the insertion detection sensor **7** may be constituted by a mechanical sensor.

The movable piece passing detection sensor **12** generates a detection signal when detecting that a distal end of the banknote T has passed through the predetermined position of the banknote conveyance mechanism **206**, and is provided upstream of the banknote reading sensor **8**. This movable piece passing detection sensor **12** is also constituted by an optical sensor or a mechanical sensor, in the same manner as the insertion detection sensor **7**.

The banknote reading sensor **8** reads banknote information of the banknote T conveyed by the banknote conveyance mechanism **206**. In this regard, the banknote information which is read by the banknote reading sensor **8** is compared to reference data stored in the ROM **212**, and the followings are determined: which country or region a currency belongs to; the money type (amount of the banknote T); and whether the banknote T is valid.

The discharge detection sensor **18** detects that a rear end of the banknote T has passed through and that the banknote T has been discharged into the banknote accommodation unit **202**, and is provided immediately upstream of the banknote accommodation unit **202**. This discharge detection sensor **18** is also constituted by an optical sensor or a mechanical sensor in the same manner as the insertion detection sensor **7**.

In the ROM **212**, the following sets of data are stored: programs such as an actuation program of the banknote conveyance mechanism **206** and a verification program regarding the banknote T which is read by the banknote reading sensor **8**; and permanent data. The CPU **210** generates a control signal based on the programs stored in the ROM **212**, sends and receives signals to and from the banknote conveyance mechanism **206** and the like through the I/O port **220**, and performs the drive control of the banknote conveyance mechanism **206** and the like. The ROM **212** further stores, regarding the inserted banknote T, reference data used for determining which country or region a currency belongs to, the money type (amount of the banknote T), and the validity of the banknote T. For example, sets of data obtained from the entire print region of a valid banknote T (e.g., data regarding light and shade and data regarding transmitted light and reflected light when

infrared light is applied to a valid banknote T) are stored. The RAM 214 stores data and a program used in operation of the CPU 210.

(Slot Machine Controller 300)

The slot machine controller 300 includes a game controller 302 which controls a process performed by the slot machine 4S, and the communication interface 301 which enables data communication with the PTS terminal 700 (see FIG. 4). Although not illustrated, the game controller 302 includes a CPU, a ROM, a RAM, and an I/O port to which members such as the control panel 30 and the game image display panel 141 are connected. The slot machine controller 300 sends, through the communication interface 301, a game result and game information such as the content of a bet betted on a game to the slot machine management server 1 through the PTS terminal 700 as a game information signal. In this regard, game information based on the game information signal received by the slot machine management server 1 is managed in the slot machine management server 1.

To be more specific, the game controller 302 runs a slot game which awards a payout based on a betted gaming value and a game result. In this slot game, twenty symbols determined randomly are displayed on a symbol display area which is formed of twenty areas forming a matrix with, e.g., five columns and four rows. In addition to that, a payout is awarded based on a displayed symbol combination (game result) and a betted gaming value.

(PTS Terminal 700)

As shown in FIG. 3, the PTS terminal 700 is inserted into the cabinet 11 from the front surface side of the slot machine 4S, and embedded in the slot machine 4S so as to form a part of the front surface of the cabinet 11. The PTS terminal 700 includes an LCD, a touch panel, a human detection camera, a microphone, a speaker, a card insertion slot, the smart interface board 710, and a storage unit 711.

The LCD displays an effect image used for an effect in a game, information when there is a payout as a game result, and a current exchange rate of each foreign currency. The touch panel is provided on the LCD to cause the PTS terminal 700 to function as an input device capable of receiving input from the outside. The human detection camera detects the presence of a player by a camera function. The microphone is used for allowing a player to participate in a game through input of player's voice and for authenticating a player by voice recognition. The speaker performs effects in a game by sound, and outputs various types of notification sound. The card insertion slot has a mechanism which allows an IC card such as a member card of a player of a game to be inserted and removed. The smart interface board 710 connected to the above-described components is a control board configured to control the components, and controls sending and receiving of signals to and from the outside. The storage unit 711 (ROM and RAM) is connected to the smart interface board 710, and makes it possible to store various information such as an exchange rate of each foreign currency.

The PTS terminal 700 is arranged to perform mediation in data communications between devices in the slot machine management server 1, the currency reading device 201, and the slot machine controller 300. Specifically, the currency reading device 201 sends the banknote information of a banknote T, which is received from the bill entry 22, to the PTS terminal 700. The PTS terminal 700 associates the received banknote information with area information showing where the slot machine 4S belongs to, and sends the associated information to the slot machine management

server 1 and the casino management system 2 via the slot machine management server 1. As described above, the PTS terminal 700 performs mediation of data communication from the currency reading device 201 to the slot machine management server 1 and data communication from the currency reading device 201 to the slot machine controller 300.

The PTS terminal 700 calculates and exchanges (replaces) a foreign currency received by the currency reading device 201 into a local currency (PHP, peso) based on information of an exchange rate which is obtained from the casino management system 2. The LCD of the PTS terminal 700 makes it possible to display a current exchange rate of a currency of each country. In this regard, the LCD displays the timing of update (changing) of the exchange rate (for example, the LCD displays update time (AM 6:00) of the exchange rate).

(Process Related to Settings for Using Currencies)

The following will describe a process with reference to FIG. 5 to FIG. 16. In the process, an administrator of the slot machine management server 1 determines that it is a season in which the number of players of a local country is large and the number of foreign players is small (because of difference of holidays between countries), limits usage of a foreign currency, and allows usage of only a local currency in the slot machines 4S placed at the areas A to D of the gaming facility 15. One reason for limiting the usage of a foreign currency is that, because maintenance is laborious if a foreign currency is available in all slot machines 4S of the gaming facility 15, maintenance costs are decreased by limiting the number of slot machines 4S in which a foreign currency is available, based on usage types (e.g., time in which the number of foreign players is low).

At the same time, the following will describe a process which limits usage of a \$100 bill of the USA banknote against gaming machines 4 placed at the areas E to H in a case in which information of the circulation of counterfeit US \$100 bills of a foreign currency is acquired from the outside of the casino system. In the slot machines 4S placed at the areas E to H, other foreign currencies are still available.

To begin with, when a person in charge of the casino management system 2 obtains information regarding the circulation of the counterfeit US \$100 bills (hereinafter, counterfeit bill information) from an international organization, an administrative organization (police), and a management department, etc., the person in charge of the casino management system 2 notifies the administrator of the slot machine management server 1 of the circulation of the counterfeit bill information from the casino management system 2.

For example, when the administrator of the slot machine management server 1 grasps the counterfeit bill information from the person in charge of the casino management system 2 by a mail displayed on the display unit 105 as shown in FIG. 10, the administrator of the slot machine management server 1 performs settings for using currencies by using currency management software and the input unit 104 of the slot machine management server 1. To be more specific, the administrator selects a currency use setting icon 501 (see FIG. 10) displayed on the display unit 105. Subsequently, as shown in FIG. 11, a status window 502 showing currently available currencies is displayed.

For the slot machines 4S placed at the areas A to D among the areas A to H of the gaming facility 15 in the present embodiment, the administrator performs settings which limit the usage of a foreign currency but allow the usage of only

a local currency (PHP, peso). For the slot machines 4S placed at the areas E to H among the areas A to H of the gaming facility 15, the administrator performs settings which allow the usage of foreign currencies, i.e., USD (US dollar), JPY (Japanese yen), CNY (yuan), and HKD (Hong Kong dollar) in addition to a local currency (PHP, peso), and limit the usage of the \$100 bill of the USA banknote for which the counterfeit bill information is acquired.

The administrator firstly selects, by a cursor 520, a "selected area 1" of a selecting area screen 507 (see FIG. 11) which is displayed on the status window 502, and then selects an additional area icon 504. Subsequently, as shown in FIG. 2, a map of the areas A to H associated with slot machines 4S provided at the gaming facility 15 is displayed on the display unit 105. In this regard, e.g., a baccarat game table 4B, roulette game machine 4R, and poker game machine 4P are provided in addition to the slot machine 4S in the areas A to H. These machines are managed by the table game management server 1A, and the administrator is allowed to perform the settings for using currencies of each of these machines, in the same manner as the slot machine management server 1.

Then, the administrator selects the areas A to D from among the areas A to H of the map of the gaming facility 15, which is displayed on the display unit 105. After the areas A to D are selected, a Next button 505 is selected to cause the shift to the status window 502 of FIG. 11. Because of this, characters of the areas A to D are displayed at an item of the "selected area 1" of the selecting area screen 507 displayed on the status window 502. The characters of the areas A to D show areas which are targets of the settings for using currencies.

Subsequently, the administrator selects the "selected area 1" by the cursor 520, and then the Next button 505 is selected to cause the shift to an available currency selection screen 508 of the "selected area 1" of FIG. 12. In this screen, the administrator selects currencies which are available at the areas A to D. For example, when PHP (peso) is selected as shown in FIG. 12, a currency of PHP (peso) of a local currency is settable to be available in the gaming machines 4 provided at the areas A to D. Meanwhile, USD (US dollar), JPY (Japanese yen), CNY (yuan), HKD (Hong Kong dollar), EUR (euro), MOP (Macanese pataca), and AUD (Australian dollar), etc., are not selected and thus are settable to be unavailable in the slot machines 4S provided at areas A to D. In the present embodiment, PHP (peso) is set as a local currency, and other currencies are treated as foreign currencies.

Subsequently, the administrator selects the Next button 505 to cause the shift to an available money type selection screen 509 of the "selected area 1" of FIG. 13. In this screen, the administrator selects available money types (banknotes T) of the currency which has been selected to be available on the available currency selection screen 508 of the "selected area 1". As shown in FIG. 13, when 1000 pesos, 500 pesos, 200 pesos, 100 pesos, 50 pesos, and 20 pesos of available PHP (peso) are selected, a \$1000 banknote, a \$500 banknote, a \$200 banknote, a \$100 banknote, a \$50 banknote, and a \$20 banknote are settable to be available in the slot machines 4S provided at the areas A to D. Meanwhile, when these banknotes are not selected, the banknotes which are not selected are unavailable in the slot machines 4S provided at the areas A to D. After that, the administrator selects the Next button 505. As a result, the selecting area screen 507 of FIG. 11 is displayed again. In this regard, contents (information of areas in which the settings for using currencies are updated, information of currencies which are

set to be available or unavailable, and information of money types which are set to be available or unavailable) of the settings for using currencies are stored in the storage unit 102.

Next, the administrator selects a "selected area 2" of the selecting area screen 507 (see FIG. 11) by the cursor 520, and then selects the additional area icon 504. Subsequently, as shown in FIG. 2, a map of the areas A to H associated with slot machines 4S provided at the gaming facility 15 is displayed on the display unit 105. Then, the administrator selects the areas E to H from among the areas A to H of the map of the gaming facility 15 which is displayed on the display unit 105. After the areas E to H are selected, the Next button 505 is selected to cause the shift to the status window 502 of FIG. 11. Because of this, characters of the areas E to H are displayed at an item of the "selected area 2" of the selecting area screen 507 displayed on the status window 502. The characters of the areas E to H show areas which are targets of the settings for using currencies.

Subsequently, the administrator selects the "selected area 2" by the cursor 520, and then the Next button 505 is selected to cause the shift to the available currency selection screen 508 of the "selected area 2" of FIG. 14. In this screen, the administrator selects currencies which are available at the areas E to H. As shown in FIG. 14, when PHP (peso), USD (US dollar), JPY (Japanese yen), CNY (yuan), and HKD (Hong Kong dollar) are selected, PHP (peso), USD (US dollar), JPY (Japanese yen), CNY (yuan), and HKD (Hong Kong dollar) become available in slot machines 4S provided at the areas E to H. Meanwhile, regarding EUR (euro), MOP (Macanese pataca), and AUD (Australian dollar) which are not selected, it is possible to set these currencies to be unavailable in the slot machines 4S provided at the areas E to H.

Subsequently, the administrator selects the Next button 505 to cause the shift to an available money type selection screen 509 of the "selected area 2" of FIG. 15. In this screen, the administrator selects available money types (banknotes T) of the currency which has been selected to be available on the available currency selection screen 508 of the "selected area 2". As shown in FIG. 15, when 1000 pesos and 500 pesos and 200 pesos and 100 pesos and 50 pesos and 20 pesos of available PHP (peso), 50 dollars and 20 dollars and 10 dollars of available USD (US dollar), 10000 yen and 5000 yen and 1000 yen of available JPY (Japanese yen), 100 yuan and 50 yuan and 20 yuan and 10 yuan of available CNY (yuan), and 500 dollars and 100 dollars and 50 dollars and 20 dollars and 10 dollars of available HKD (Hong Kong dollar) are selected, these banknotes are settable to be available in the slot machines 4S provided at the areas E to H. Meanwhile, regarding the \$100 banknote of USD which is not selected by the administrator who grasps the counterfeit bill information, it is possible to set the banknote to be unavailable in the slot machines 4S provided at the areas E to H. After that, the administrator selects the Next button 505. As a result, the selecting area screen 507 of FIG. 11 is displayed again. In this regard, contents (information of areas in which the settings for using currencies are updated, information of currencies which are set to be available or unavailable, and information of money types which are set to be available or unavailable) of the settings for using currencies are stored in the storage unit 102.

Then, when the administrator selects a completion button 521, a confirmation screen (not illustrated) is displayed. After the confirmation is accepted, the settings for using currencies are completed.

On the status window **502** (see FIG. **11**), available currency selection screen **508** (see FIG. **12** and FIG. **14**), and available money type selection screen **509** (see FIG. **13** and FIG. **15**), etc., an exchange rate button **506** is displayed to cause the shift to an exchange rate screen **510** (see FIG. **16**) showing the current exchange rate of each currency. On the status window **502**, the available currency selection screen **508**, and the available money type selection screen **509**, etc., a Back button **503** which enables to go back to a prior page is also displayed.

(Available Currency Management Process)

The following will describe an available currency management process performed in the slot machine management server **1**, with reference to a flowchart of FIG. **5**.

To begin with, the above-described settings for using currencies are performed by the input unit **104** (**S101**: input process). Subsequently, the center controller **101** determines whether the settings for using currencies are completed in the input process (**S102**). If the settings for using currencies have not been completed (NO in **S102**), completion of the settings for using currencies is waited.

Meanwhile, if the settings for using currencies have been completed (YES in **S102**), the settings for using currencies which are stored in the storage unit **102** are updated (**S103**). For example, when the areas A to D ("selected area 1"; see FIG. **11**) are selected from among the areas A to H of the map of the gaming facility **15** as described above, the settings for using currencies in correspondence with the selected area **1** are updated in the slot machines **4S** provided at the areas A to D (update of information of available or unavailable currencies and update of information of available or unavailable money types; see FIG. **13**). For another example, when the areas E to H ("selected area 2"; see FIG. **11**) are selected from among the areas A to H of the map of the gaming facility **15**, the settings for using currencies in correspondence with the selected area **2** are updated in the slot machines **4S** provided at the areas E to H (update of information of available or unavailable currencies and update of information of available or unavailable money types; see FIG. **15**). Then, this process is terminated.

In the slot machine management server **1** with the arrangement above, for example, when (i) the areas E to H (selected area **2**) are selected as arbitrary areas from among the areas A to H, (ii) PHP (peso), USD (US dollar), JPY (Japanese yen), CNY (yuan), and HKD (Hong Kong dollar) are selected as arbitrary currencies from among a variety of currencies, and (iii) 1000 pesos, 500 pesos, 200 pesos, 100 pesos, 50 pesos, and 20 pesos of PHP (peso), 50 dollars, 20 dollars, and 10 dollars of USD (US dollar), 10000 yen, 5000 yen, and 1000 yen of JPY (Japanese yen), 100 yuan, 50 yuan, 20 yuan, and 10 yuan of CNY (yuan), and 500 dollars, 100 dollars, 50 dollars, 20 dollars, and 10 dollars of HKD (Hong Kong dollar) are selected as arbitrary money types from among a variety of money types by the input unit **104**, a process which allows the usage of the selected money types of the selected currencies is performable only for each of currency handling systems **100** mounted in the slot machines **4S** provided performable at the selected areas E to H, through the communication interface **103** of the slot machine management server **1**. Because of this, even in a gaming facility **15** provided with a lot of currency handling systems **100** in each of which a variety of currencies are available, it is possible to freely set areas in which selected money types of selected currencies are available and areas in which the selected money types of the selected currencies are unavailable.

In this regard, when the settings for using currencies are updated in the step **S103**, information of the settings for using currencies is sent to PTS terminals **700** at the area where the settings have been done, and kinds of available and unavailable currencies and money types are updated to be displayable on LCDs of the PTS terminals **700** or on display devices of the slot machines **4S**. Alternatively, on LCDs of the PTS terminals **700** or on the display devices of the slot machines **4S**, only kinds of available currencies and money types may be displayed and kinds of unavailable currencies and money types may not be displayed. (Banknote Receiving Process)

A banknote receiving process will be described with reference to a flowchart of FIG. **6**. The banknote receiving process is performed by a CPU **210** of a control circuit board **200A** when a currency reading device **201** mounted at a slot machine **4S** receives a banknote T from a bill entry **22** after the settings for using currencies are updated in the available currency management process described above, in the slot machine management server **1**.

To begin with, the CPU **210** determines whether a valid banknote T is inserted from the bill entry **22** (**S201**). If a valid banknote T has not been inserted (NO in **S201**), the CPU **210** performs the step **S201** again and waits for the insertion of a valid banknote T.

Meanwhile, if a valid banknote T has been inserted (YES in **S201**), the CPU **210** obtains banknote information of the inserted banknote T based on a signal from the banknote reading sensor **8** (**S202**). To be more specific, the followings are obtained as the banknote information: a kind of the inserted banknote T (currency such as PHP, peso; USD, US dollar; JPY, Japanese Yen; CNY, yuan; HKD, Hong Kong dollar; EUR, euro; MOP, Macanese pataca; AUD, Australian dollar); and a money type of the banknote T (e.g., monetary amount such as \$100 banknote, \$50 banknote, \$20 banknote, and \$10 banknote, etc., in USD; US dollar).

Subsequently, the CPU **210** sends the banknote information which has been obtained in the step **S202** to the PTS terminal **700**. The PTS terminal **700** which has received the banknote information sends a banknote information signal to the slot machine management server **1** (**S203**). The banknote information signal is a signal in which the received banknote information is associated with area information showing to which area the slot machine **4S** belongs. In this regard, the banknote information signal is a signal which is sent from the PTS terminal **700** to the casino management system **2**, the slot machine management server **1**, and the slot machine controller **300**, etc. This banknote information signal is formed in such a way that the above-described banknote information, read from the banknote T by the banknote reading sensor **8**, is associated with area information. The area information shows to which area the slot machine **4S**, including the currency reading device **201** which has read the banknote T, belongs.

In this regard, when the slot machine management server **1** receives a banknote information signal (details thereof will be described later), whether the currency of the banknote indicated by the signal is an available currency is determined based on the received banknote information signal and the settings, stored in the slot machine management server **1**, for using currencies (information of areas in which the settings for using currencies are performed, information of currencies which are set to be available or unavailable, and information of money types which are set to be available or unavailable). If it is an available currency, a use permission signal is sent to the currency reading device **201** through the PTS terminal **700** of the slot machine **4S** which has sent the

banknote information signal. Meanwhile, if it is an unavailable currency, a non-permission signal is sent to the currency reading device 201 through the PTS terminal 700 of the slot machine 4S which has sent the banknote information signal.

Subsequently, the CPU 210 determines whether a use permission signal sent through the PTS terminal 700 from the slot machine management server 1 is received (S204). If a use permission signal has not been received (NO in S204), the CPU 210 determines whether a non-permission signal sent through the PTS terminal 700 from the slot machine management server 1 is received (S205). In addition to that, if a non-permission signal has not been received (NO in S205), the step S204 is performed again.

Meanwhile, if a non-permission signal has been received (YES in S205), the inserted banknote T is discharged from the bill entry 22 (S206: discharge process). For example, a banknote T is inserted into a slot machine 4S provided at the area E, and EUR (euro) is not selected on the available currency selection screen 508 of the selected area 2 of FIG. 14 and is set as an unavailable currency. In this case, every inserted euro banknote is determined as a money type of the unavailable currency and discharged from a bill entry 22. Because of this, usage of euro banknotes is limited (stopped) in such a way that the euro banknotes are discharged even if the euro banknotes are inserted from the bill entry 22. In this regard, EUR is set as the unavailable currency in the slot machine 4S provided at the area E. For another example, a banknote T is inserted into the slot machine 4S provided at the area E, and a \$100 banknote of USD is not selected on the available money type selection screen 509 of the selected area 2 of FIG. 15 and is set as an unavailable money type of a currency. In this case, the inserted \$100 banknote of USD is determined as the unavailable money type of the currency and discharged from the bill entry 22. Because of this, usage of \$100 banknotes is limited (stopped) in such a way that the \$100 banknotes are discharged even if the \$100 banknotes are inserted from the bill entry 22. A \$100 banknote is set as the unavailable money type of the currency in the slot machine 4S provided at the area E. Then, after the discharge process of S206, the routine goes back to S201.

If the use permission signal has been received in the step S204 (YES in S204), the CPU 210 conveys the inserted banknote T to a banknote accommodation unit 202 and stores the inserted banknote T (S207). For example, a banknote T is inserted into the slot machine 4S provided at the area E, and \$50 banknote and \$20 banknote and \$10 banknote of USD are selected on the available money type selection screen 509 of the selected area 2 of FIG. 15 and are set as available money types of an available currency. In this case, the inserted \$50 banknote and the inserted \$20 banknote and the inserted \$10 banknote are determined as the available money types of the available currency, conveyed to the banknote accommodation unit 202, and then housed.

Subsequently, the CPU 210 sends the banknote information which has been obtained in the step S202 to the PTS terminal 700 (S208).

(Usage Checking Process)

A usage checking process will be described with reference to a flowchart of FIG. 7. The usage checking process is performed by the center controller 101 of the slot machine management server 1 when the slot machine management server 1 receives the banknote information signal which has been sent from the PTS terminal 700 in the step 203 of the banknote receiving process described above.

To begin with, the center controller 101 determines whether the banknote information signal having been sent from the PTS terminal 700 in the step S203 of the banknote

receiving process described above is received (S301). If the banknote information signal has not been received (NO in S301), supply of the signal is waited.

Meanwhile, if the banknote information signal has been received (YES in S301), the center controller 101 performs an unavailable currency reference process (S302). In this unavailable currency reference process, banknote information (kind of the inserted banknote T, currency; and money type of the inserted banknote T) of the received banknote information signal and area information (information of the area where the slot machine 4S including the PTS terminal 700 which has sent the banknote information signal is provided) associated with the banknote information are compared with the settings for using currencies, stored in the storage unit 102. (The settings for using currencies are information of areas in which the settings for using currencies are performed, information of currencies which are set to be available or unavailable, and information of money types which are set to be available or unavailable.)

As a result of the unavailable currency reference process, when the slot machine 4S including the PTS terminal 700 which has sent the banknote information signal corresponds to the area in which the settings for using currencies are performed, the center controller 101 determines whether the banknote T inserted into the currency reading device 201 mounted in the slot machine 4S which has sent the banknote information signal is an unavailable banknote whose money type of a currency is set to be unavailable (S303). Meanwhile, if it has been determined that the inserted banknote T is an unavailable banknote whose money type of a currency is set to be unavailable (YES in S303), a non-permission signal is sent to the currency reading device 201 through the PTS terminal 700 of the slot machine 4S which has sent the banknote information signal (S304).

Meanwhile, if it has been determined that the inserted banknote T is not an unavailable banknote whose money type of a currency is set to be unavailable (NO in S303), a use permission signal is sent to the currency reading device 201 through the PTS terminal 700 of the slot machine 4S which has sent the banknote information signal (S305). Then, this process is terminated.

In the slot machine management server 1 with the arrangement above, for example, when the areas A to D (selected area 1) are selected as arbitrary areas from among the areas A to H and only banknotes of a local currency (PHP, peso) are selected (see FIG. 13) as an arbitrary currency from among a variety of currencies by the input unit 104, a process which allows the usage of selected banknotes of a local currency is performable only for each of the currency reading devices 201 mounted in the slot machines 4S provided at the selected areas A to D from the communication interface 103 of the slot machine management server 1. Because of this, even in a gaming facility 15 provided with a lot of currency handling systems 100 in each of which a variety of currencies are available, areas in which only the selected local currency is available are freely settable. In the, e.g., slot machine management server 1 with the arrangement above, when (i) the areas E to H (selected area 2) are selected as arbitrary areas from among the areas A to H, (ii) PHP (peso), USD (US dollar), JPY (Japanese yen), CNY (yuan), and HKD (Hong Kong dollar) are selected as arbitrary currencies from among a variety of currencies, and (iii) 1000 pesos, 500 pesos, 200 pesos, 100 pesos, 50 pesos, and 20 pesos of PHP (peso), 50 dollars, 20 dollars, and 10 dollars of USD (US dollar), 10000 yen, 5000 yen, and 1000 yen of JPY (Japanese yen), 100 yuan, 50 yuan, 20 yuan, and 10 yuan of CNY (yuan), and 500 dollars,

100 dollars, 50 dollars, 20 dollars, and 10 dollars of HKD (Hong Kong dollar) are selected as arbitrary money types from among a variety of money types by the input unit 104, a process which allows the usage of the selected money types of the selected currencies is performable only for each currency handling system 100 mounted in the slot machines 4S provided at the selected areas E to H, through the communication interface 103 of the slot machine management server 1. Because of this, even in a gaming facility 15 provided with a lot of currency handling systems 100 in each of which a variety of currencies are available, it is possible to freely set areas in which selected money types of selected currencies are available and areas in which the selected money types of the selected currencies are unavailable. (Banknote Information Receiving Process)

A banknote information receiving process will be described with reference to a flowchart of FIG. 8. The banknote information receiving process is performed by the smart interface board 710 when the PTS terminal 700 receives the banknote information which has been sent in the step S208 of the banknote receiving process described above.

To begin with, the smart interface board 710 determines whether the banknote information which has been sent from the currency reading device 201 is received (S401). If the banknote information has not been received (NO in S401), supply of the banknote information is waited.

Meanwhile, if the banknote information has been received (YES in S401), the smart interface board 710 determines whether a kind of a banknote T which is read from the banknote information is a foreign currency, i.e., whether it is one of currencies except PHP (peso) of a local currency (S402). In the present embodiment, USD (US dollar), JPY (Japanese yen), CNY (yuan), and HKD (Hong Kong dollar), etc., are foreign currencies.

If information indicating the kind of the banknote T which is read from the banknote information has been determined as one of foreign currencies (YES in S402), the smart interface board 710 performs an exchange rate obtain process (S403). In this exchange rate obtain process, the casino management system 2 is accessed (asked) through the slot machine management server 1 from the PTS terminal 700, and an exchange rate is obtained. The exchange rate is stored in the storage unit 402 of the casino management system 2, and corresponds to the foreign currency which is the type read from the banknote information. For example, when the foreign currency which is the type read from the banknote information is US dollar, an exchange rate is obtained. The exchange rate ("USD/PHP") regulates an exchange ratio which is used for exchanging US dollar of a foreign currency into PHP (peso) of a local currency. In this regard, the obtained exchange rate is stored in the storage unit 711.

Subsequently, the smart interface board 710 calculates and exchanges (replaces) a money type (monetary amount) of the foreign currency into a monetary amount of a local currency (PHP, peso) with reference to the exchange rate which has been obtained in the step S403 (S404). In this regard, the foreign currency is the type read from the banknote information.

In this step, the exchange rate of a currency of each country which is stored in the storage unit 402 of the casino management system 2 is an exchange ratio from a foreign currency which is available in the gaming machine 4 (e.g., slot machine 4S which is managed by the slot machine management server 1, and baccarat game table 4B and roulette game table 4R which are managed by the table game management server 1A) provided in the gaming facility 15

to a local currency (PHP, peso), and is updated by manual input from the input unit 404 at every predetermined time. The manual input is made by the person in charge of the casino management system 2 who has obtained information of the exchange rate from the outside. In the present embodiment, at every predetermined time (e.g., AM 6:00), the person in charge of the casino management system 2 grasps the latest information of the exchange rate of each foreign currency and manually updates the exchange rate of a currency of each country which is stored in the storage unit 402. In this regard, the update of the exchange rate may be performed at a wide variety of timing in accordance with a kind of the currency. In the present embodiment, the update of the exchange rate in the casino management system 2 is manually performed. Alternatively, the exchange rate in the casino management system 2 may be automatically updated by automatically obtaining exchange rates from the outside. Alternatively, instead of the predetermined time, the exchange rate may be adjusted to an exchange rate which varies in real time. Information of the exchange rate is sent to a PTS terminal 700 of each slot machine 4S through the slot machine management server 1. Because of this, a PTS terminal 700 which has obtained the exchange rate is able to display a current exchange rate of a currency of each country onto an LCD.

In the step S404, for example, when an exchange rate "USD/PHP" obtained from the casino management system 2 is "53. 100" (one US dollar is exchanged into 53. 100 pesos) and a money type (monetary amount) of a foreign currency is a \$10 banknote of USD, it is calculated and exchanged into 531 pesos of a local currency. In this regard, the foreign currency is the type read from the banknote information.

Meanwhile, if it is determined that the kind of the banknote T which has been read from the banknote information in the step S402 is not one of foreign currencies (i.e., determined as PHP, peso, of local currency; NO in S402), or after the step S404, the smart interface board 710 performs a credit information signal sending process (S405). In this credit information signal sending process, when the kind of the banknote T which has been read from the banknote information in the step S402 is PHP (peso) of a local currency, a monetary amount of the money type is sent to the slot machine controller 300 as a credit information signal. For example, when the kind of the banknote T which has been read from the banknote information in the step S402 is 500 pesos of a local currency, the 500 pesos are sent to the slot machine controller 300 as a credit information signal. When a foreign currency has been calculated and exchanged into a local currency, i.e., into PHP (peso) in the step S404, the exchanged monetary amount of the local currency is sent to the slot machine controller 300 as a credit information signal. For example, when a \$10 banknote of USD has been calculated and exchanged into 531 pesos of a local currency in the step S404, the 531 pesos are sent to the slot machine controller 300 as a credit information signal. After that, the step S401 is performed again. (Slot Game Running Process)

A flowchart of a slot game running process will be described with reference to FIG. 9. The slot game running process is performed by the game controller 302 of the slot machine controller 300 of the slot machine 4S.

To begin with, the game controller 302 determines whether a credit information signal is received from the PTS terminal 700 (S501). If a credit information signal has been received (YES in S501), the game controller 302 adds a monetary amount (PHP, peso, of local currency) based on

the credit information signal to an owned credit counter of a RAM (S502). The owned credit counter of the RAM shows a monetary amount which is owned by a player.

After the step S502, or if a credit information signal has not been received (NO in S501), the game controller 302 performs a game process (S503). In this game process, a slot game is performed by a player. The slot game awards a payout based on a betted monetary amount (amount which is betted from the owned credit counter) and a game result. In this slot game, twenty symbols randomly determined are displayed on a symbol display area which is formed of twenty areas forming a matrix with, e.g., five columns and four rows. In addition to that, a payout is awarded based on a displayed symbol combination (game result) and a betted monetary amount.

The awarded payout is added to the owned credit counter (S504). In this regard, e.g., information based on a game result is sent to the slot machine management server 1 through the PTS terminal 700, and managed in the slot machine management server 1.

Other Embodiments

In the embodiment described above, the administrator of the slot machine management server 1 performs the settings for using currencies by manual input with the input unit 104 and the currency management software. However, the disclosure is not limited to this. When the counterfeit bill information is received from the outside such as the casino management system 2, the slot machine management server 1 may automatically perform the settings for using currencies based on the counterfeit bill information.

In the present embodiment described above, the currency handling system 100 is embedded in the gaming machine 4 such as the slot machine 4S. However, the disclosure is not limited to this. Alternatively, the currency handling system 100 may be a terminal device connected to an external apparatus such as a money exchanger, a vending machine, and a ticket machine. Alternatively, the currency handling system 100 may not be embedded in the terminal device. While in the present embodiment the currency handling system 100 is provided for each gaming machine 4, one currency handling system 100 may be provided for plural gaming machines 4.

In the embodiment described above, if the settings for using currencies have been completed (YES in S102), the settings for using currencies which are stored in the storage unit 102 are updated. In other words, the settings for using currencies are managed in the slot machine management server 1. However, the disclosure is not limited to this. The contents of the settings, set in the slot machine management server 1, for using currencies may be sent to the PTS terminal 700 and may be stored and managed in the storage unit 711. Because of this, in the storage unit 711 of the PTS terminal 700, the settings for using currencies (e.g., information of currencies which are set to be available or unavailable, information of money types which are set to be available or unavailable, and information of areas in which the settings for using currencies are performed) are updated. In this case, the usage checking process (see FIG. 7) is performed in the PTS terminal 700.

The exchange rates may be managed in the slot machine management server 1. Alternatively, a process of exchanging each foreign currency into a local currency may be performed in the casino management system 2 or the slot machine management server 1.

While in the present embodiment the slot machine management server 1 and the casino management system 2 play a role of the management server, one server may play a role of the management server.

In the present embodiment, \$100 banknotes of USD are set as an unavailable money type of an unavailable currency in the areas E to H (selected area 2). The \$100 banknotes of USD are discharged so as to limit (stop) usage of the \$100 banknotes of USD even if the \$100 banknotes of USD are inserted from the bill entry 22. Meanwhile, the limit of usage of a currency which is set as an unavailable currency may be achieved by stopping an exchange function in which the PTS terminal 700 exchanges (replaces) a foreign currency into a local currency (PHP, peso). The foreign currency is the type read in the currency reading device 201. In this case, the slot machine management server 1 sends, to the PTS terminal 700, a command which stops (limits) exchange of the currency used at the currency reading device 201.

Embodiments of the present invention thus described above solely serve as specific examples of the present invention, and are not to limit the scope of the present invention. The specific structures and the like are suitably modifiable. Further, the effects described in the embodiment of the present invention described in the above embodiment are no more than examples of preferable effects brought about by the present invention, and the effects of the present invention are not limited to those described hereinabove.

REFERENCE SIGNS LIST

- 1 management server
- 2 casino management system
- 3 network
- 4 gaming machine
- 4S slot machine
- 100 currency handling system
- 101 center controller
- 102 storage unit
- 103 communication interface
- 104 input unit
- 105 display unit
- 201 currency reading device
- 300 slot machine controller
- 700 PTS terminal
- T banknote

The invention claimed is:

1. A management server which is connected, through a communication line, to a plurality of currency handling systems,
 - each of the plurality of currency handling systems including a currency reading device capable of reading a plurality of banknotes in a plurality of currencies and a player tracking system (PTS) terminal, the currency reading device in communication with the player tracking system (PTS) terminal, and the player tracking system (PTS) terminal in communication with the management server;
 - each of the plurality of currency handling systems being provided at a respective gaming machine configured to award a payout based on a bet game value and a game result;
 - each of the plurality of currency handling systems being associated with at least one of a plurality of different floor areas;
 - each of the different floor areas including at least two currency handling systems and at least two different types of gaming machine;

each of the different floor areas classified in accordance with a minimum required bet game value at each respective gaming machine associated therewith, the at least two different gaming machines of a first floor area of the plurality of different floor areas having a minimum required bet that is different from the at least two different gaming machines of a second floor area of the plurality of different floor areas,

the management server comprising:

an input unit which allows selection of a floor area from among the plurality of different floor areas and a selection of at least one of the plurality of banknotes in at least one of the plurality of currencies corresponding to a selected floor area;

a transmitter which is configured to send a command to each of the plurality of currency handling systems; and

a controller which is programmed to perform processes of:

(a) via the input unit of the management server, receiving a selection of at least one floor area from among the plurality of different floor areas, and a selection of at least one of the plurality of banknotes in the at least one of the plurality of currencies to correspond therewith; and

(b) where a respective currency handling system associated with a respective gaming machine in the selected floor area has received and read a respective banknote in a currency associated with the selected at least one of the plurality of currencies, and banknote information including floor area information corresponding to the location of the currency handling system receiving the respective banknote is transmitted to the management server via the player tracking system (PTS) terminal, via the transmitter of the management server, sending a command to the respective currency handling system having received the respective banknote allowing the respective currency handling system to accept the respective banknote in the currency received and read.

2. The management server according to claim 1, wherein the input unit of the management server further allows selection of at least one banknote amount from among a plurality of banknote amounts in the at least one of the plurality of currencies, and,

the controller is programmed to perform processes of:

(a) via the input unit of the management server, receiving a selection of the at least one of the floor areas from among the plurality of different floor areas, a selection of at least one of the plurality of banknotes in the at least one of the plurality of currencies to correspond therewith, and a selection of at least one of the plurality of banknote amounts from among the plurality of banknote amounts in the at least one of the plurality of currencies that is acceptable; and

(b) where a respective currency handling system associated with a respective gaming machine in the selected floor area has received and read a respective banknote in the currency associated with the selected at least one of the plurality of currencies, and the banknote information including banknote amount information and floor area information corresponding to the location of the currency handling system receiving the respective banknote is transmitted to the management server via the player tracking system (PTS) terminal, via the transmitter of the man-

agement server, sending a command to the respective currency handling system allowing the respective currency handling system to accept the respective banknote amount in the currency received and read.

3. The management server of claim 1, wherein when a respective currency handling system associated with a respective gaming machine in the selected at least one of the plurality of different floor areas received and read a respective banknote in a currency that is not associated with the selected at least one of the plurality of currencies, via the transmitter, sending a command to the respective currency handling system disallowing the respective currency handling system to accept the respective currency received and read.

4. The management server of claim 1, wherein the selection of the at least one of the plurality of currencies for at least one floor area concurrently designates the at least one of the plurality of currencies accepted at each of the currency handling systems in the selected at least one floor area.

5. A management server which is connected, through a communication line, to a plurality of currency handling systems,

each of the plurality of currency handling systems including a currency reading device capable of reading a plurality of banknotes in a plurality of currencies and a player tracking system (PTS) terminal, the currency reading device in communication with the player tracking system (PTS) terminal, and the player tracking system (PTS) terminal in communication with the management server;

each of the plurality of currency handling systems being provided at a respective gaming machine configured to award a payout based on a bet game value and a game result;

each of the plurality of currency handling systems being associated with at least one of a plurality of different floor areas;

each of the different floor areas including at least two currency handling systems and at least two different types of gaming machine;

each of the different floor areas classified in accordance with a minimum required bet game value at each respective gaming machine associated therewith, the at least two different gaming machines of a first floor area of the plurality of different floor areas having a minimum required bet that is different from the at least two different gaming machines of a second floor area of the plurality of different floor areas,

wherein, the management server displays a graphical user interface that allows:

a selection of at least one of the plurality of different floor areas;

a selection of at least one accepted currency associated with the selected at least one of the plurality of different floor areas from among a plurality of currencies; and,

a selection of at least one accepted banknote amount from among a plurality of banknote amounts in the selected at least one currency;

wherein, based on the selected at least one of the plurality of different floor areas, the selected at least one accepted currency, and the selected at least one acceptable banknote amount being received at the management server, and where a respective currency handling system associated with a respective gaming machine in the selected at least one floor area has received and read a respective banknote in the at least one accepted

currency and accepted banknote amount, and banknote information including currency type information, banknote amount information, and floor area information corresponding to the location of the currency handling system receiving the respective banknote is transmitted to the management server via the player tracking system (PTS) terminal, the management server executes a process of transmitting a command to each of the plurality of currency handling systems within the selected at least one of the plurality of different floor areas, which allows use of the selected and accepted at least one accepted currency and at least one accepted banknote amount in the selected at least one of the plurality of different floor areas.

6. The management server of claim 5, where when a respective currency handling system associated with a respective gaming machine in the selected at least one of the plurality of different floor areas has received and read a respective banknote associated with the selected at least one of the plurality of currencies in a selected and accepted banknote amount, via the transmitter, sending a command to each of the plurality of currency handling systems in the selected different floor area allowing the currency handling systems thereof to accept the respective currency and the banknote amount received and read, and wherein when a respective currency handling system associated with a respective gaming machine in the selected at least one of the plurality of different floor areas has received and read a respective banknote that is not associated with the selected and accepted at least one of the plurality of currencies or selected and accepted banknote amounts, via the transmitter, sending a command to each of the respective currency handling systems in the selected different floor area disallowing the currency handling systems from accepting the respective currency received and read.

7. A management server which is connected, through communication line, to a plurality of currency handling systems,

each of the plurality of currency handling systems including a currency reading device capable of reading a plurality of banknotes in a plurality of currencies and a player tracking system (PTS) terminal, the currency reading device in communication with the player tracking system (PTS) terminal, and the player tracking system (PTS) terminal in communication with the management server;

each of the plurality of currency handling systems being associated at least one of a plurality of different floor areas;

each of the plurality of different floor areas including at least two currency handling systems and at least two different types of gaming machine;

each of the different floor areas classified in accordance with a minimum required bet game value at each respective gaming machine associated therewith, the at least two different gaming machines of a first floor area of the plurality of different floor areas having a minimum required bet that is different from the at least two different gaming machines of a second floor area of the plurality of different floor areas,

the management server comprising:
a display unit that displays each of the plurality of different floor areas, at least one of a plurality of currency types that can be selected for acceptance at each of the different floor areas, and at least one of

a plurality of banknote amounts that can be selected for acceptance at each of the plurality of different floor areas, and;

an input unit that allows selection of:

at least one of the at least one of the plurality of different floor areas displayed on the display unit, at least one of the plurality of currency types that are to be accepted by the plurality of currency handling systems associated with a respective different floor area displayed on the display unit, and at least one of the plurality of banknote amounts that are to be accepted by the plurality of currency handling systems associated with a respective different floor area displayed on the display unit;

a non-transitory computer readable storage medium that stores information corresponding to a selected currency type and a selected banknote currency amount that is to be accepted at each of the plurality of currency handling systems associated with a selected respective different floor area displayed on the display unit;

a transmitter that sends a command to each of the currency handling systems associated with the selected respective different floor area displayed on the display unit;

a controller which is programmed to perform processes of:

(a) receiving and storing as currency usage information including:

a selection of at least one of the at least one of the plurality of different floor areas displayed on the display unit,

a selection of at least one of the plurality of currency types that are to be accepted by the plurality of currency handling systems associated with the selected at least one of the plurality of different floor areas, and

a selection of at least one of the plurality of banknote amounts that are to be accepted by the plurality of currency handling systems associated with the selected at least one of the plurality of different floor areas;

(b) receiving banknote information obtained by at least one of the plurality of currency handling systems associated with the at least one of the respective selected plurality of different floor areas, the banknote information including currency type information, banknote amount information, and floor area information corresponding to the location of the currency handling system receiving a respective banknote;

(c) comparing the currency type information, the banknote amount information, and the floor area information obtained from the at least one of the plurality of currency handling systems associated with the at least one of the respective selected plurality of different floor areas, with the currency usage information associated with the respective at least one of the plurality of currency handling systems associated with the respective at least one of the selected plurality of different floor areas; and,

(d) based on the comparison, transmitting a use or a non-use signal to each of the currency handling

systems associated with the respective at least one of the selected plurality of different floor areas.

* * * * *