



US011874025B2

(12) **United States Patent**
Suetsugu

(10) **Patent No.:** **US 11,874,025 B2**
(45) **Date of Patent:** **Jan. 16, 2024**

(54) **AIR CURTAIN APPARATUS**
(71) Applicant: **Katsunori Suetsugu**, Tokyo (JP)
(72) Inventor: **Katsunori Suetsugu**, Tokyo (JP)
(*) Notice: Subject to any disclaimer, the term of this patent is extended or adjusted under 35 U.S.C. 154(b) by 169 days.

(21) Appl. No.: **17/448,827**
(22) Filed: **Sep. 24, 2021**
(65) **Prior Publication Data**
US 2022/0163223 A1 May 26, 2022

(30) **Foreign Application Priority Data**
Nov. 24, 2020 (JP) 2020-194073
Apr. 8, 2021 (JP) 2021-065799
Apr. 8, 2021 (JP) 2021-065800

(51) **Int. Cl.**
F24F 7/06 (2006.01)
F24F 11/74 (2018.01)
(Continued)

(52) **U.S. Cl.**
CPC **F24F 7/06** (2013.01); **F24F 8/20** (2021.01); **F24F 11/74** (2018.01);
(Continued)

(58) **Field of Classification Search**
CPC F24F 7/06; F24F 8/20; F24F 11/74; F24F 2009/007; F24F 2120/12; F24F 2221/02; F24F 9/00
(Continued)

(56) **References Cited**
U.S. PATENT DOCUMENTS
3,827,862 A * 8/1974 Berlant A61L 9/20 422/121
4,123,967 A * 11/1978 Shanis F24F 9/00 285/125.1
(Continued)

FOREIGN PATENT DOCUMENTS
EP 2942577 A1 * 11/2015 F24F 9/00
JP 1973026208 U 7/1973
(Continued)
Primary Examiner — Avinash A Savani
Assistant Examiner — Dana K Tighe
(74) *Attorney, Agent, or Firm* — Simpson & Simpson, PLLC; S. Peter Konzal

(57) **ABSTRACT**
[SUMMARY]
[Problems to be Solved]
To provide an air curtain apparatus that is small and simple, capable of separating a space, and capable of preventing entry of foreign matters such as droplets from one subspace into the other subspace.
[Solution]
An air curtain apparatus 1 includes a plurality of blowers 11 arrayed in an up-down direction and a plurality of second blowers 21 arrayed in the up-down direction. An air inlet port 23 included in the blower 21 faces an air outlet port 14 included in the blower 11. In a pair of the blower 11 and the blower 21, the blower 11 blows out a helical air current SA1 from the air outlet port 14, and the blower 21 sucks in the helical air current SA1 from the air inlet port 23. The air curtain apparatus 1 forms an air curtain AC1 with a plurality
(Continued)

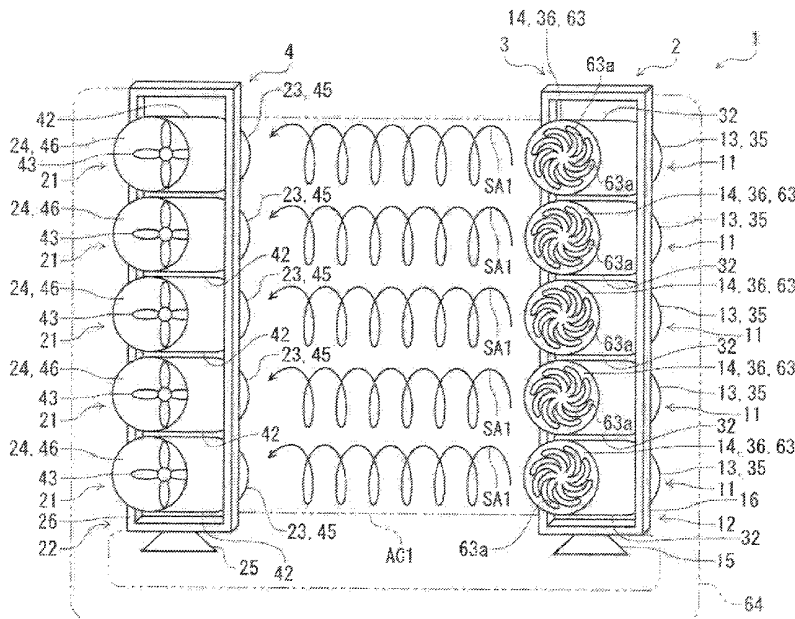

of the helical air currents SA1, the plurality of the helical air currents SA1 being blown from the plurality of the air outlet ports 14 and sucked into the plurality of air inlet ports 23.

26 Claims, 30 Drawing Sheets

- (51) **Int. Cl.**
F24F 8/20 (2021.01)
F24F 120/12 (2018.01)
F24F 9/00 (2006.01)
- (52) **U.S. Cl.**
 CPC *F24F 2009/007* (2013.01); *F24F 2120/12*
 (2018.01); *F24F 2221/02* (2013.01)
- (58) **Field of Classification Search**
 USPC 454/341
 See application file for complete search history.

(56)

References Cited

U.S. PATENT DOCUMENTS

8,376,822	BI *	2/2013	Smith	A61N 7/02	454/188
2009/0291627	A1 *	11/2009	Zimmermann	F24F 9/00	700/275
2017/0080465	A1 *	3/2017	Ding	E05F 15/60	
2022/0054699	A1 *	2/2022	Nakama	F24F 7/003	

FOREIGN PATENT DOCUMENTS

JP	1974017778	U	5/1975
JP	19979187567	A	7/1997
JP	2002213390	A	7/2002
JP	2008174081	A	7/2008
JP	2008188188	A	8/2008
JP	2017025472	A	2/2017
KR	20150118464	A	10/2015
WO	2016157675	A1	10/2016

* cited by examiner

FIG. 1

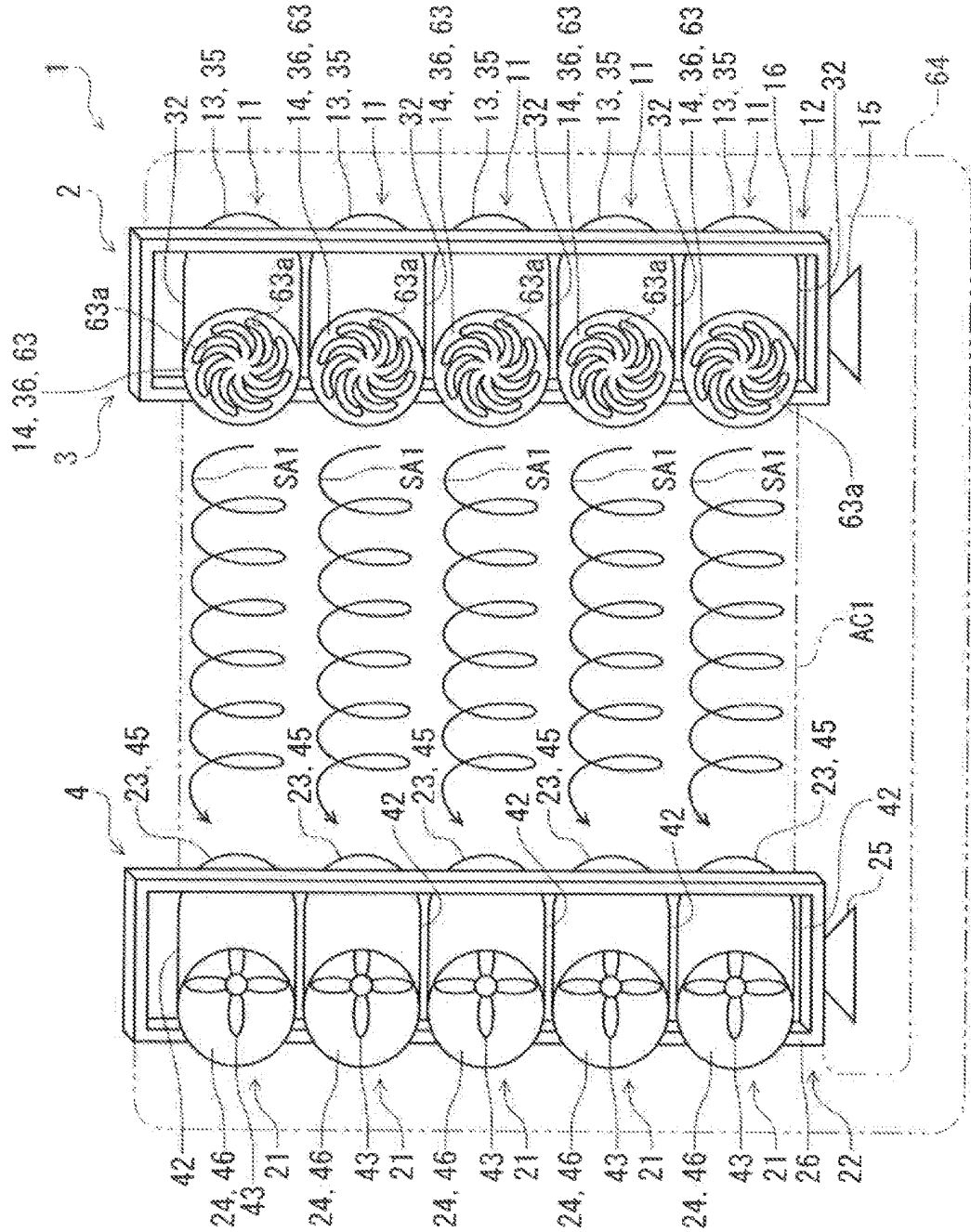

FIG. 2

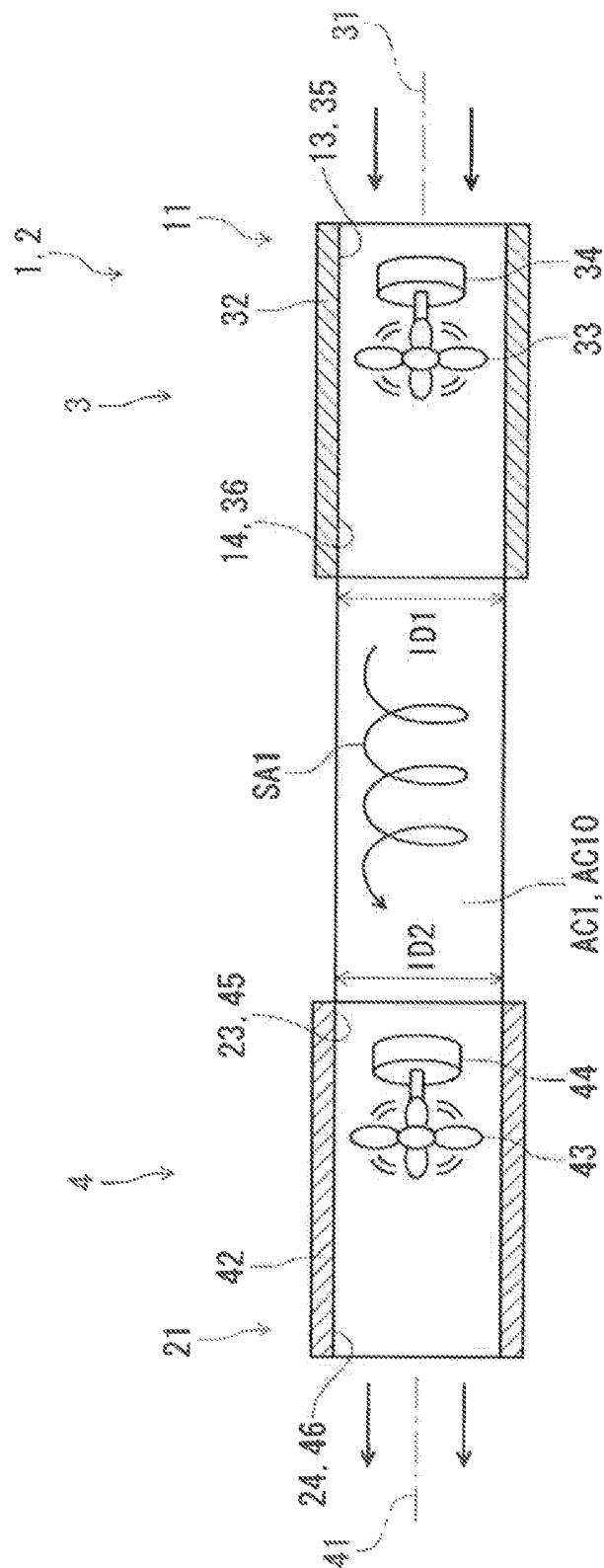

FIG.3

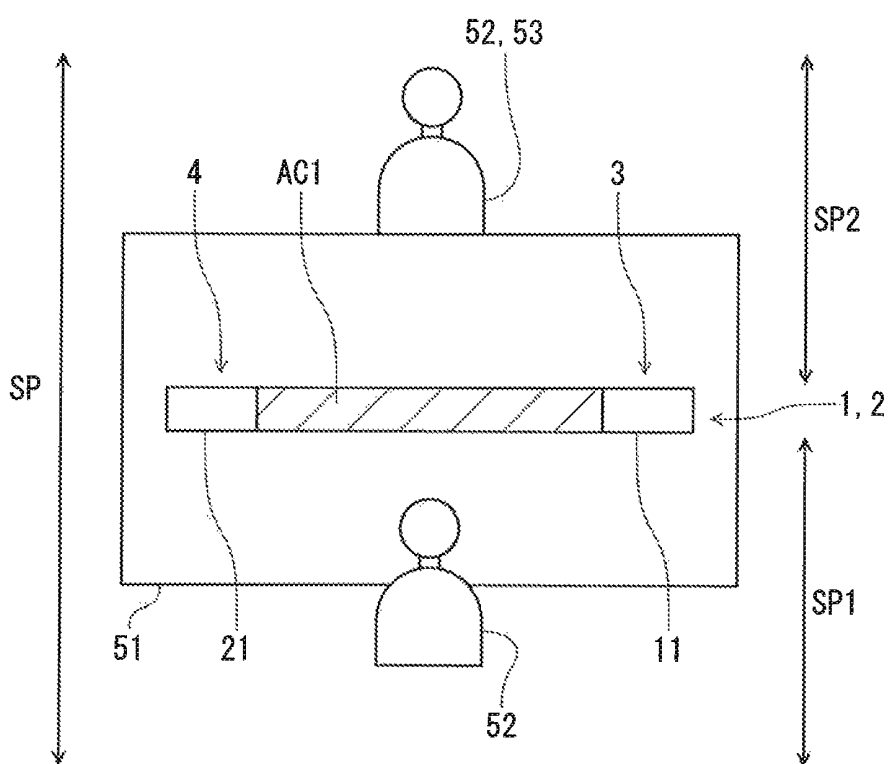

FIG. 4

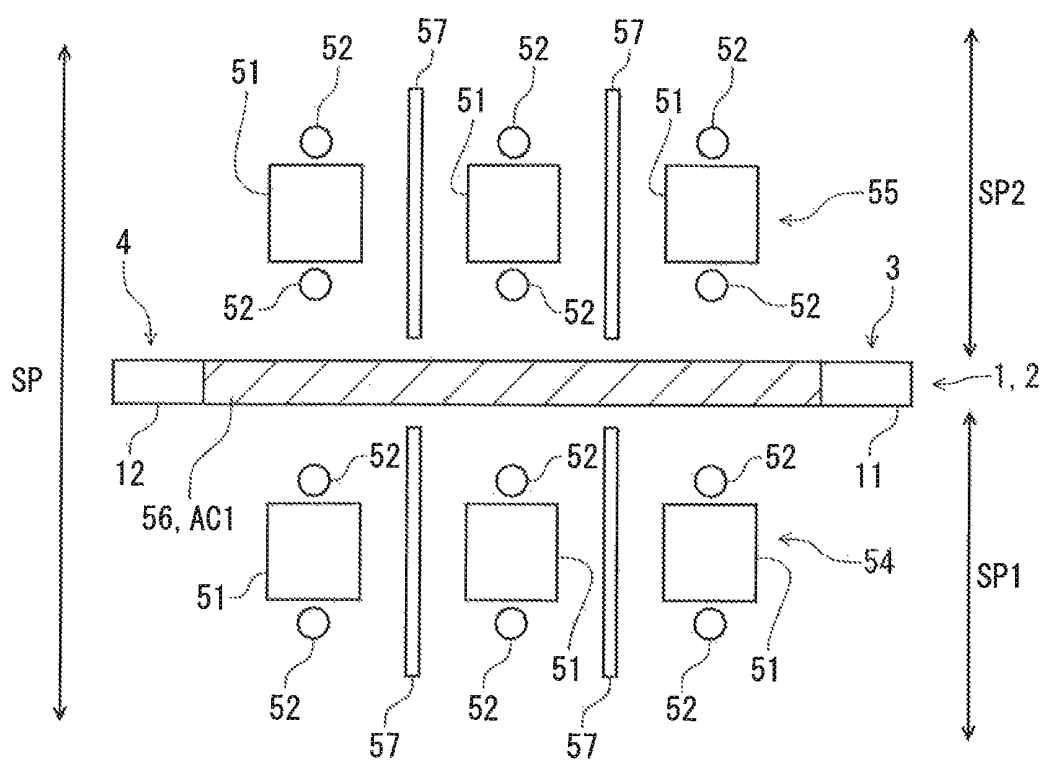

FIG. 5

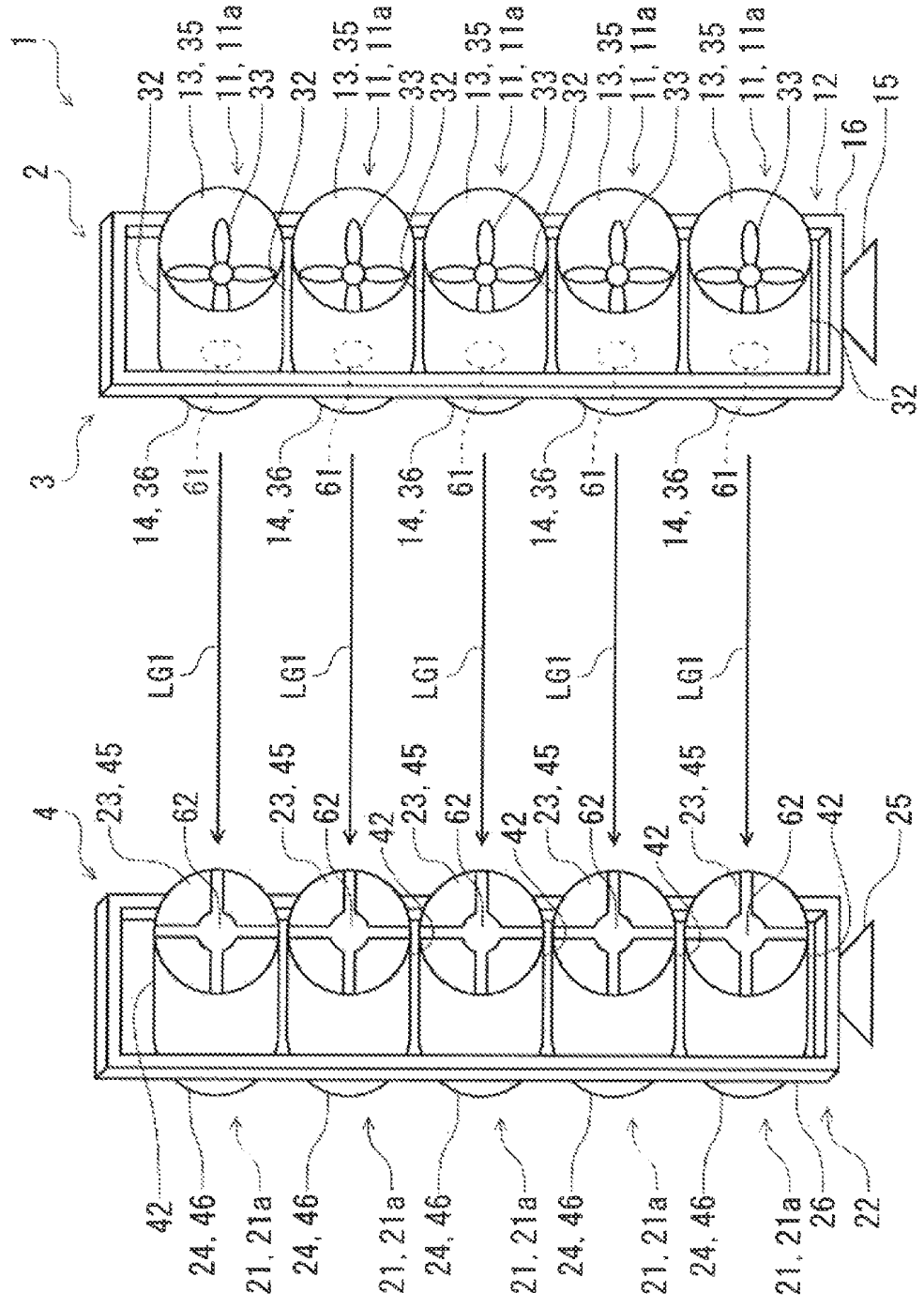

FIG. 6

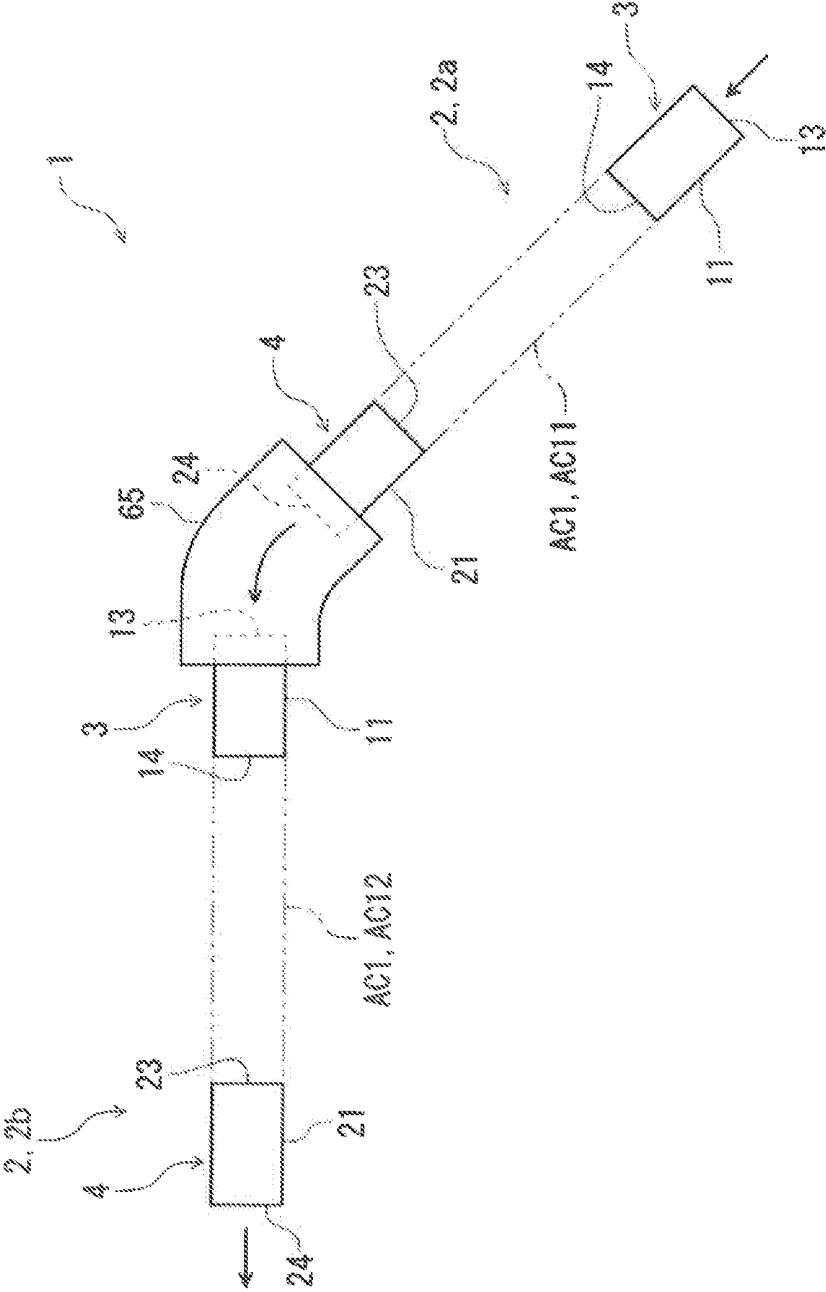

FIG. 7

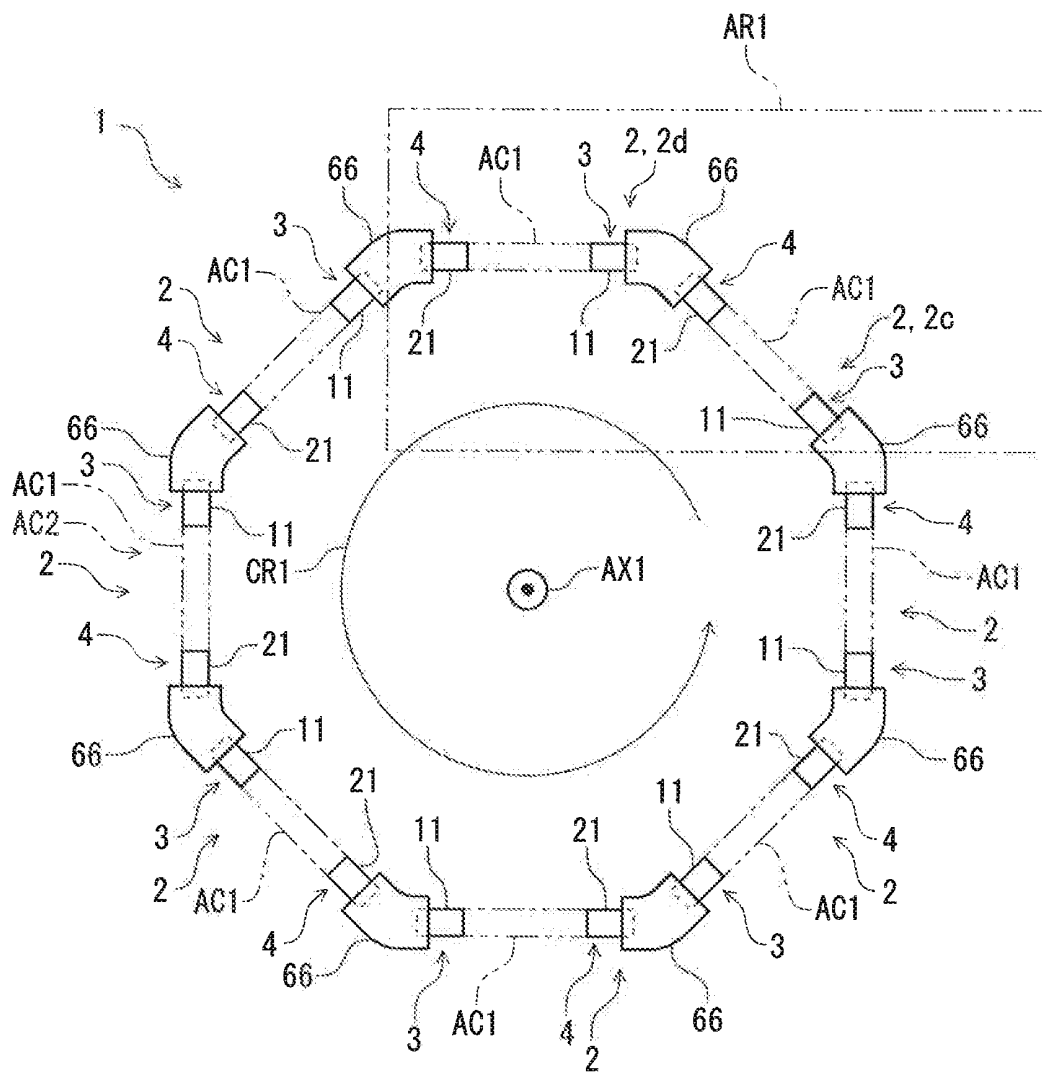

FIG. 8

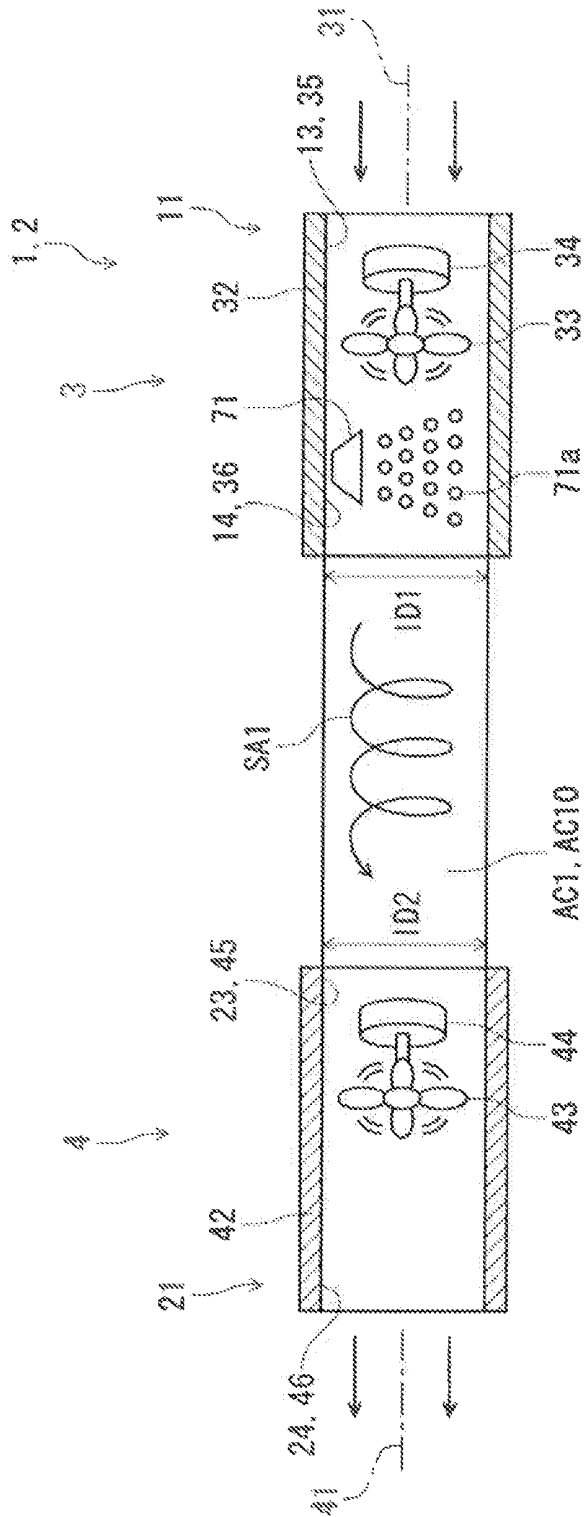

FIG. 10

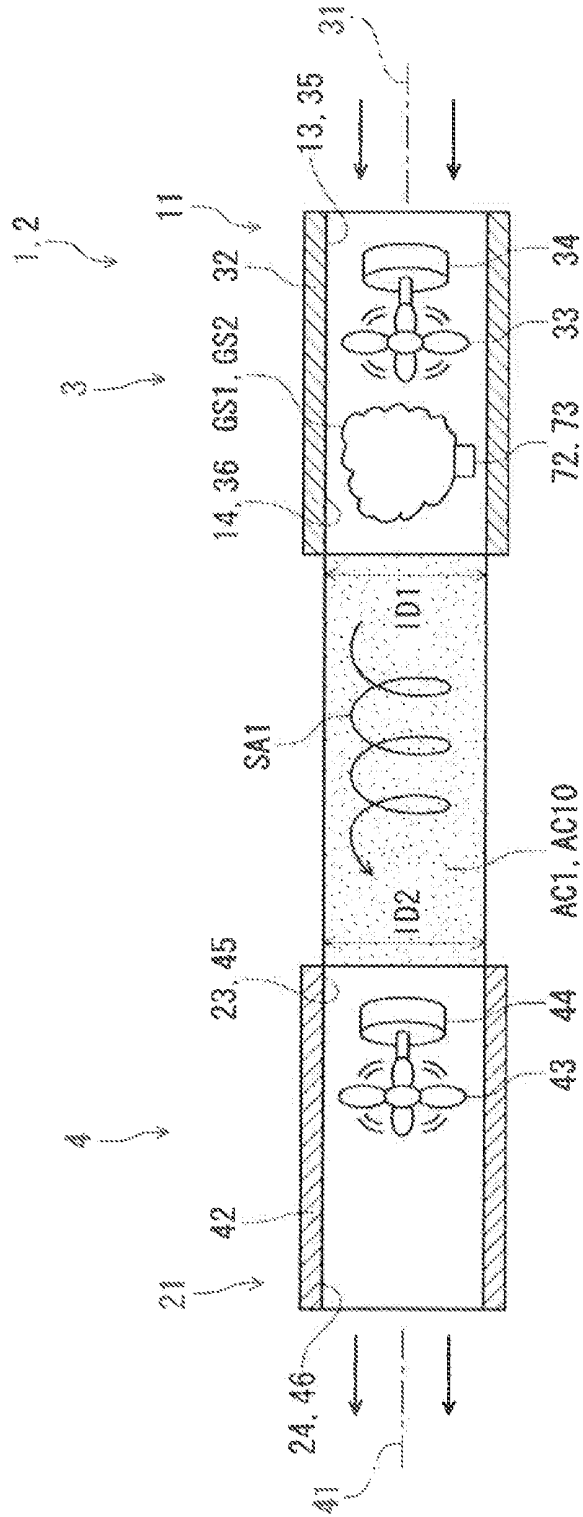

FIG.11A

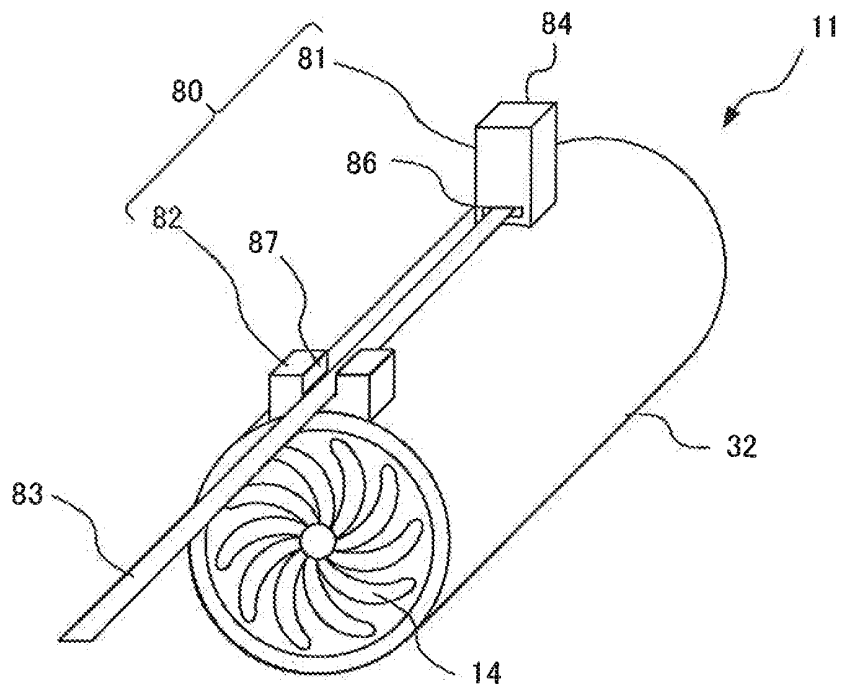

FIG.11B

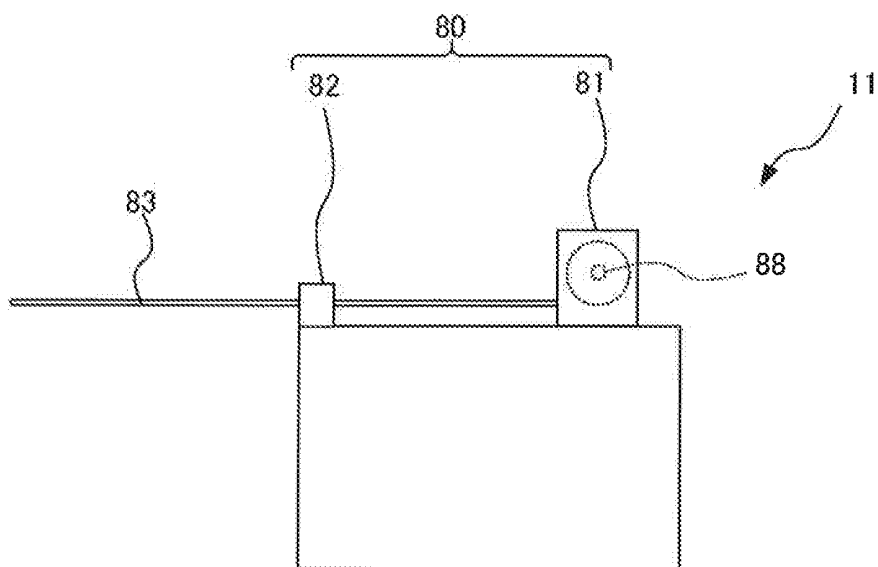

FIG.12A

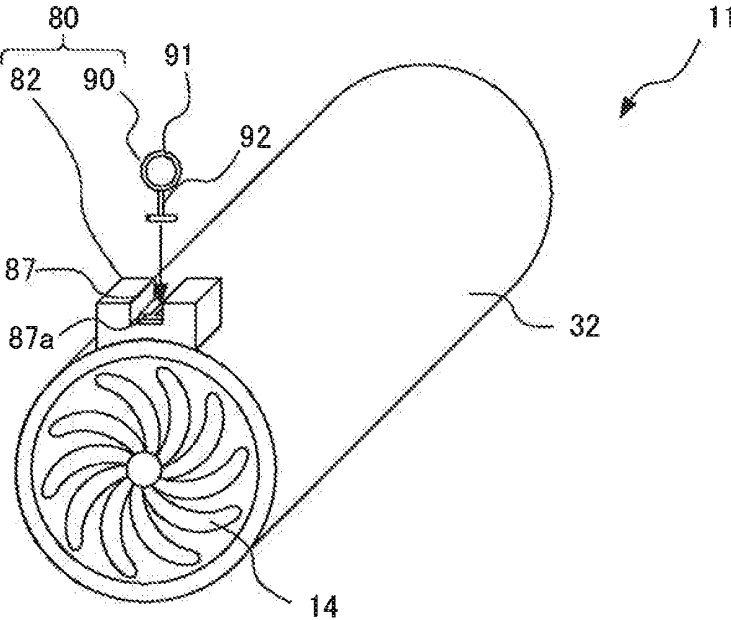

FIG.12B

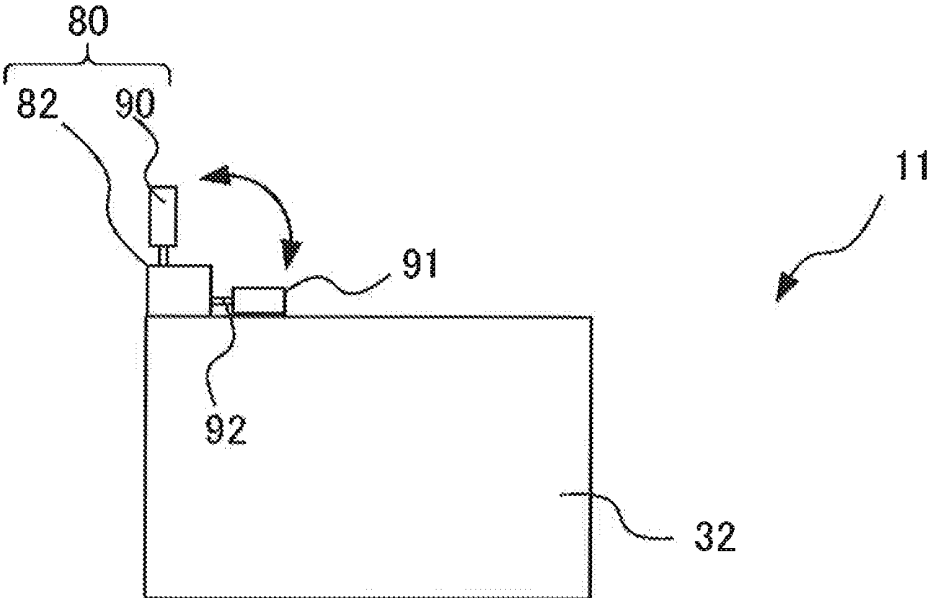

FIG.13A

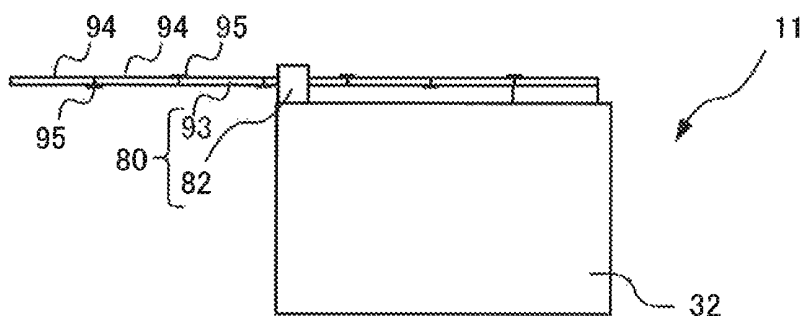

FIG.13B

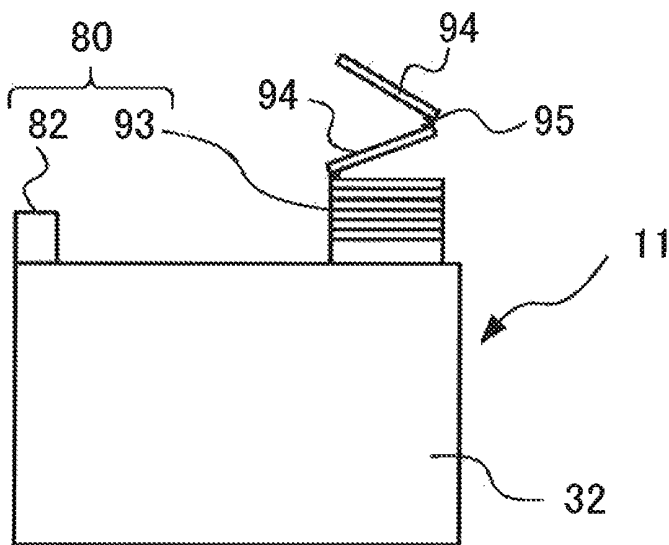

FIG.14A

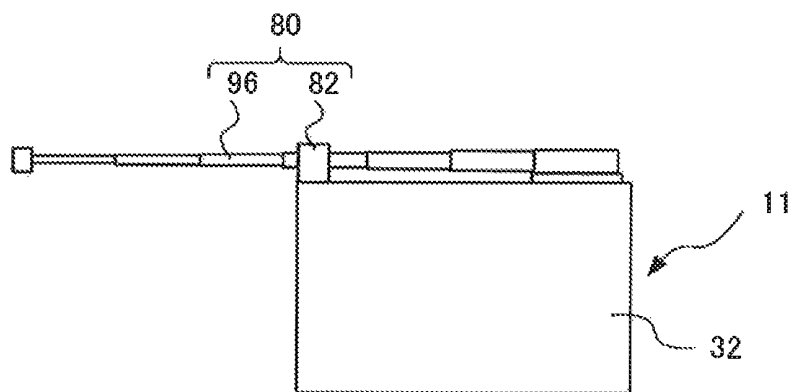

FIG.14B

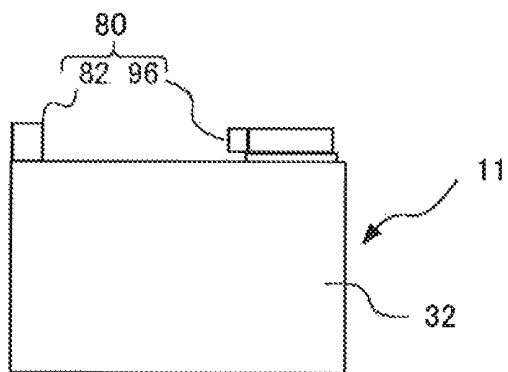

FIG.15A

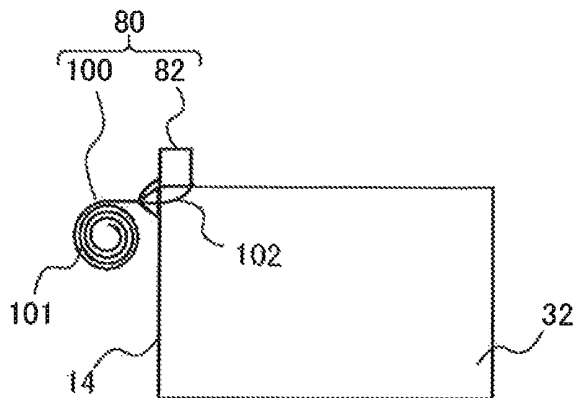

FIG.15B

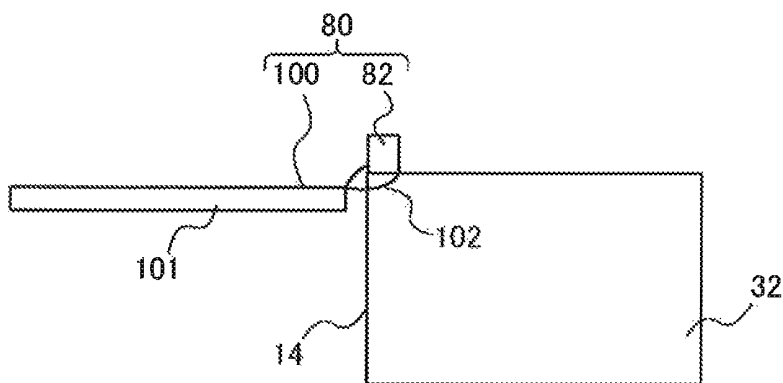

FIG.15C

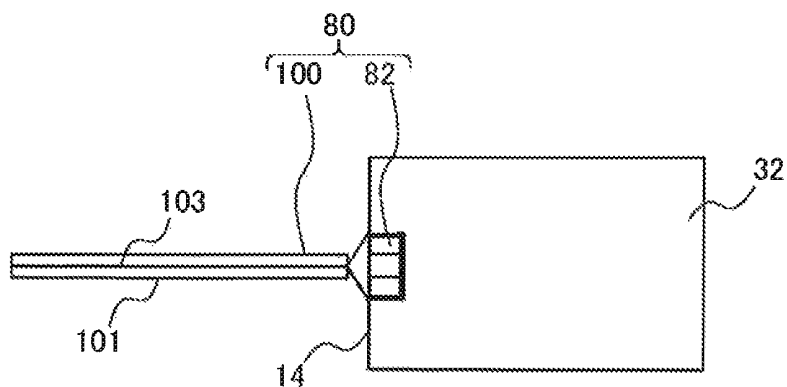

FIG. 16

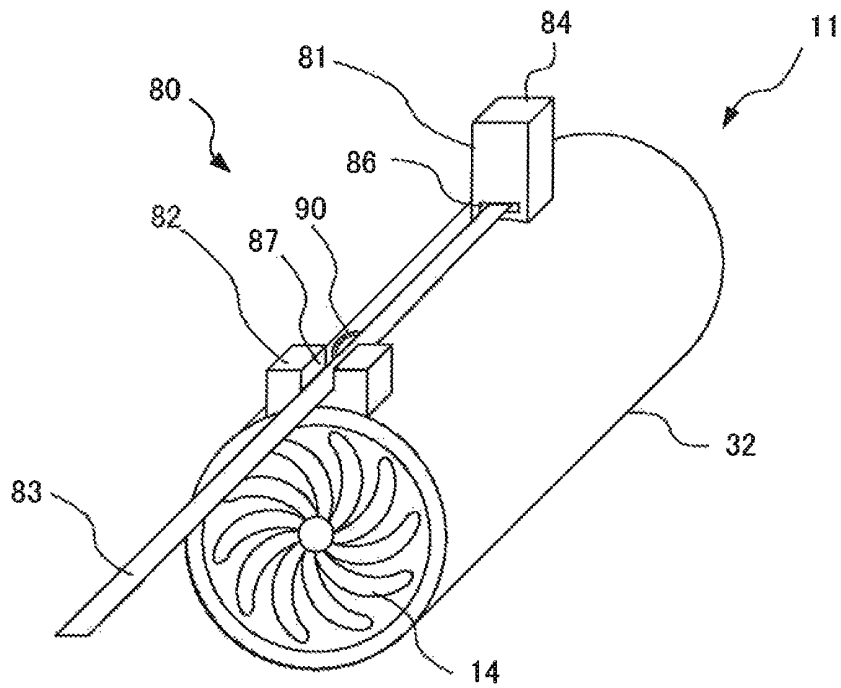

FIG. 17

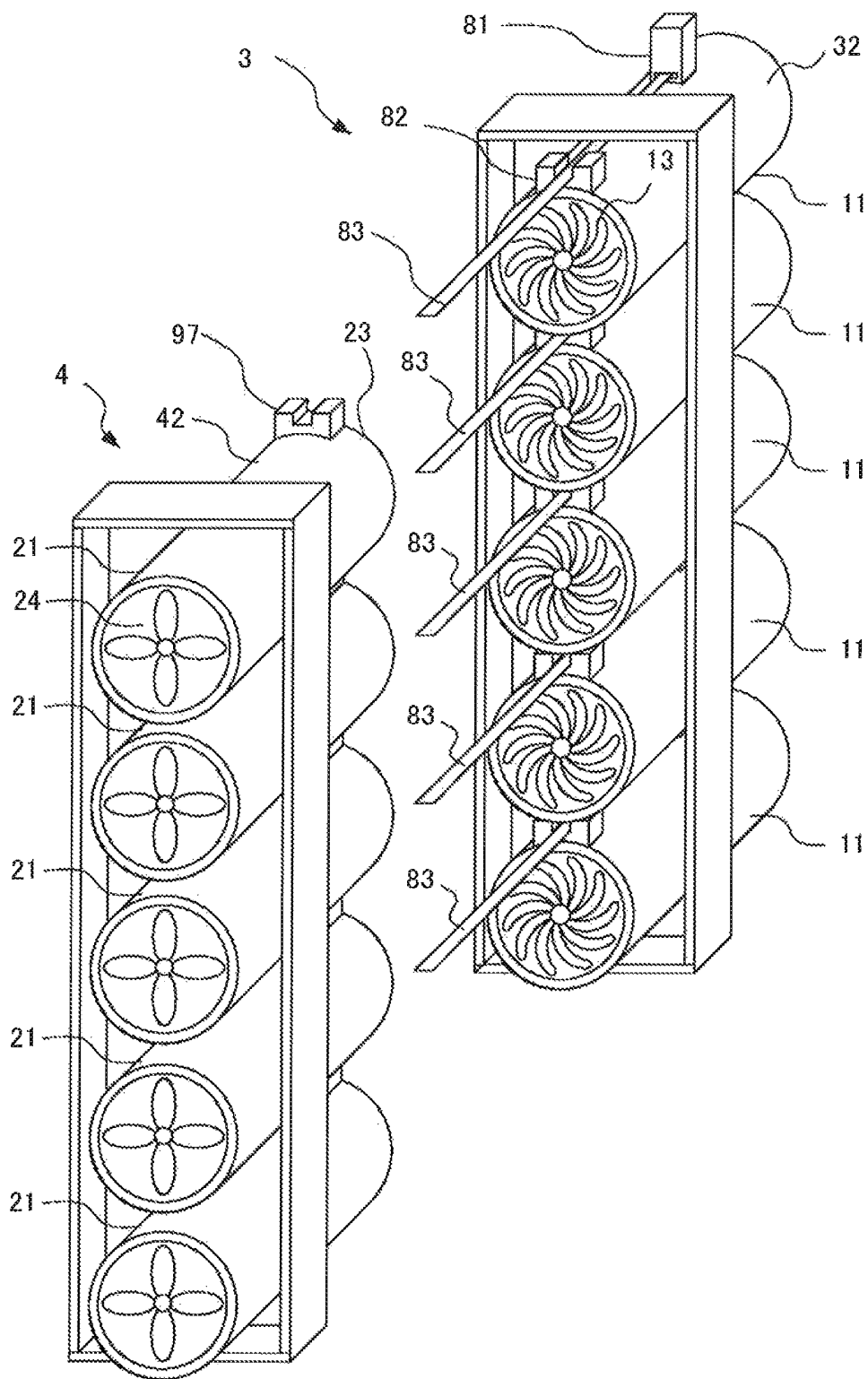

FIG. 18

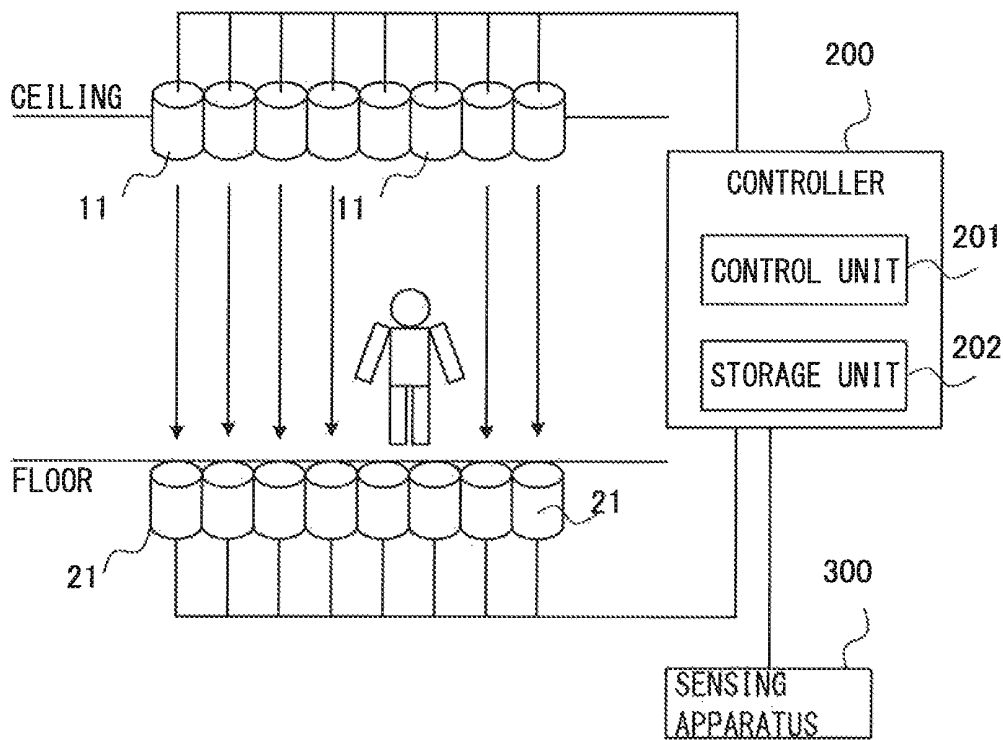

FIG. 19

(FLOWCHART OF VENTILATION PROCESS PERFORMED BY CONTROLLER 200)

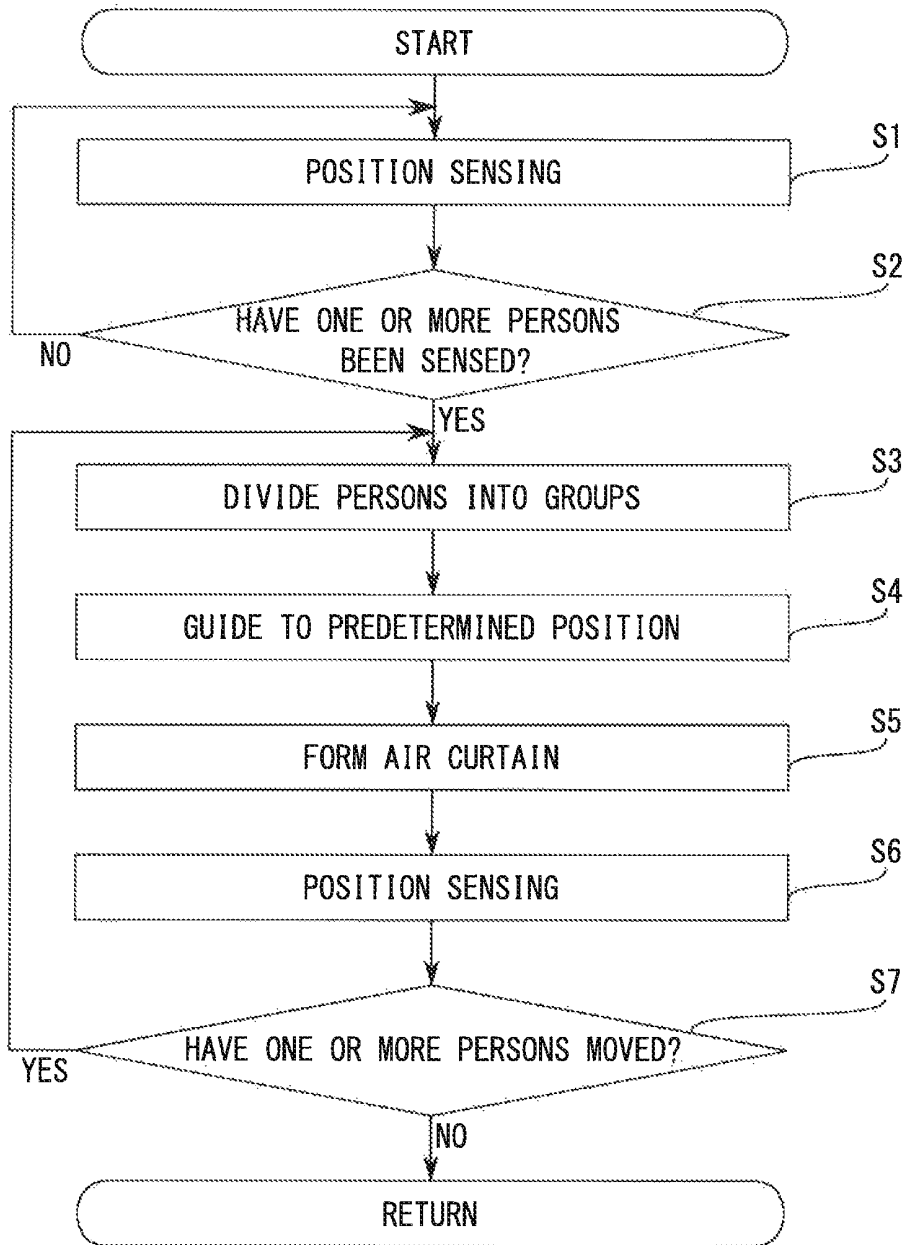

FIG.20

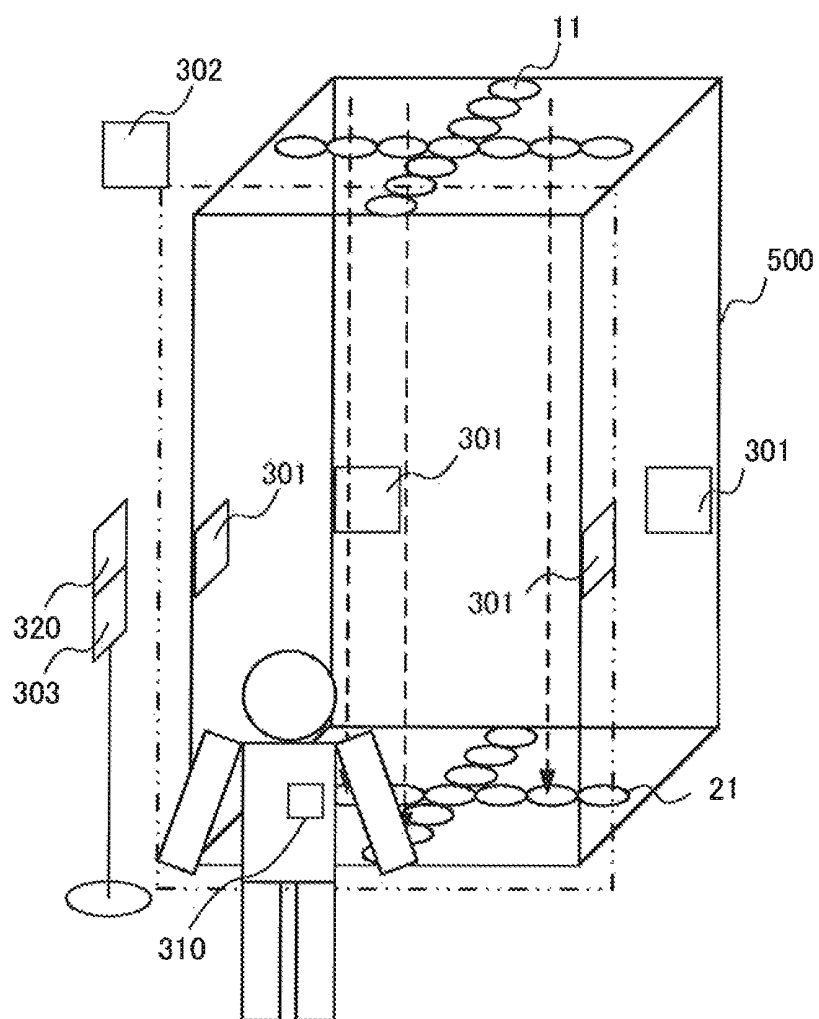

FIG.21A

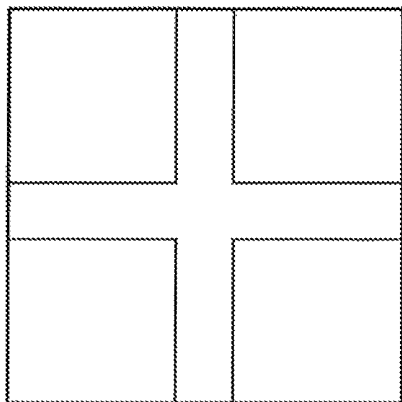

FIG.21B

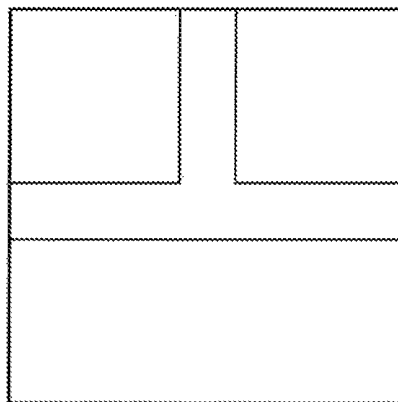

FIG.21C

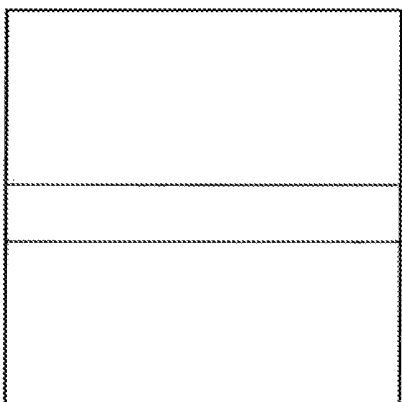

FIG.21D

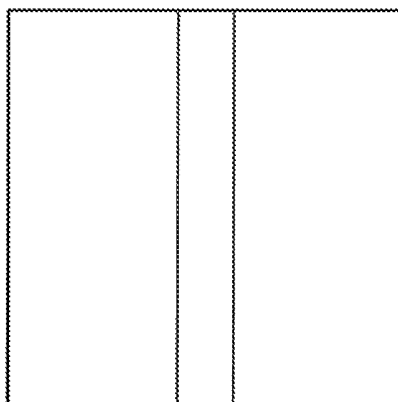

FIG.21E

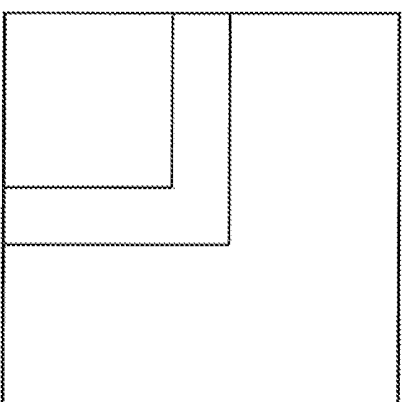

FIG.21F

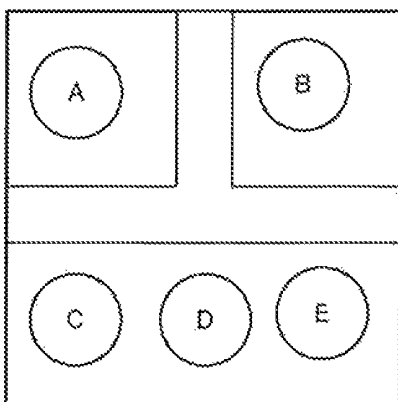

FIG.22

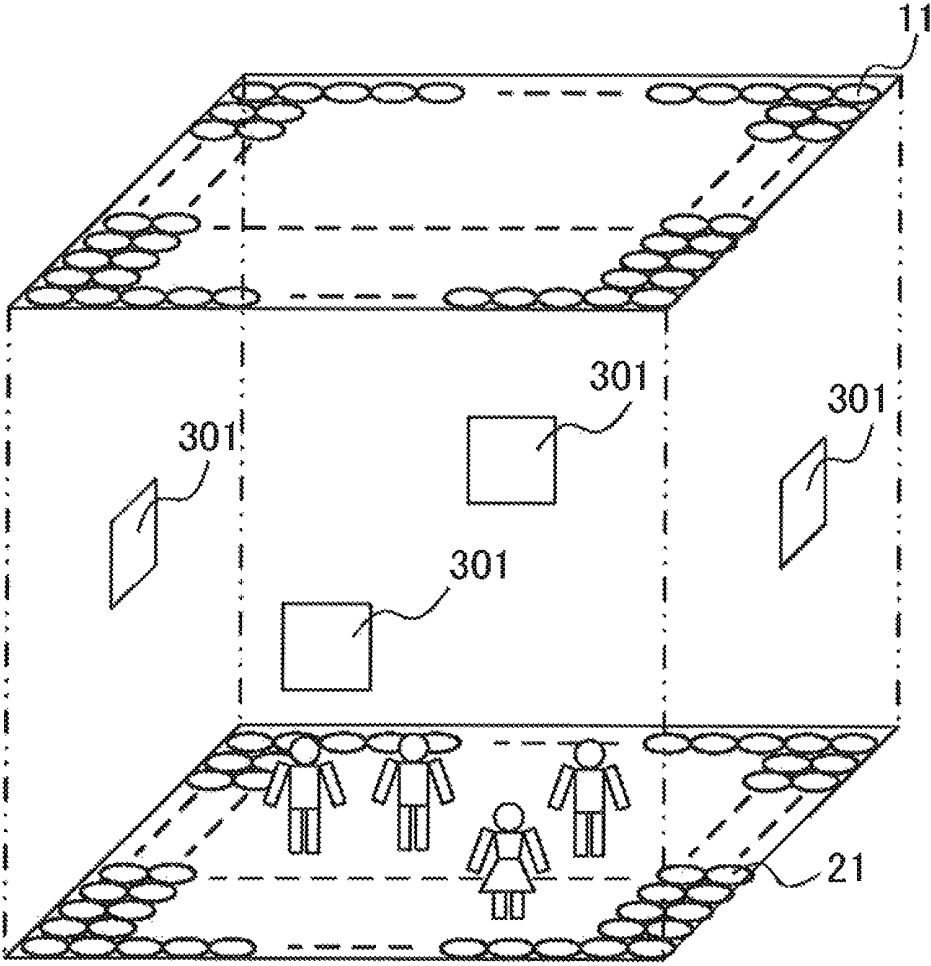
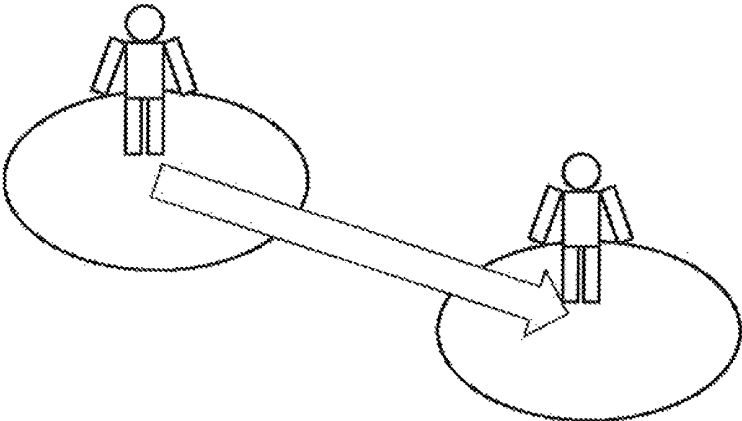

FIG.23



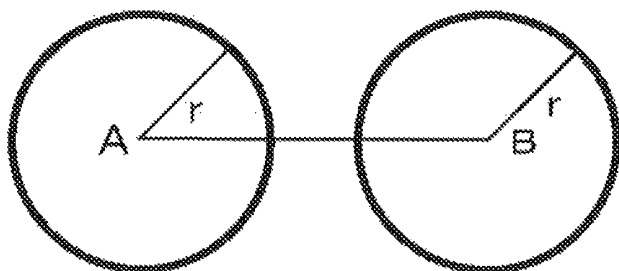

FIG.24A

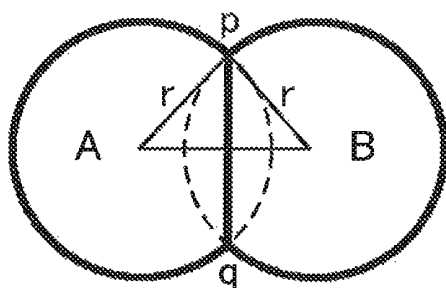

FIG.24B

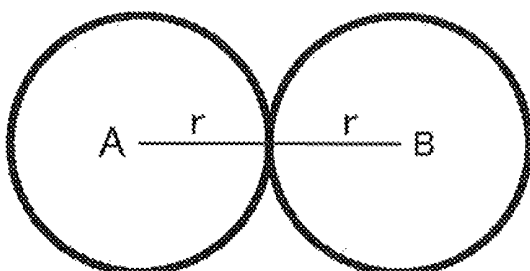

FIG.24C

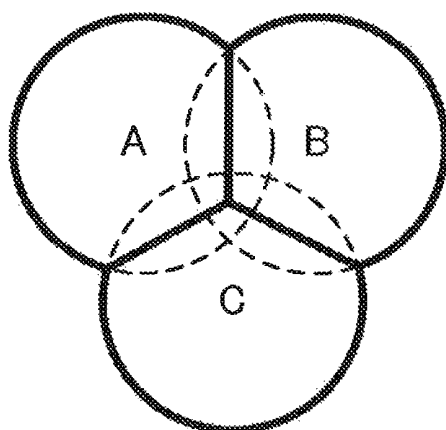

FIG.24D

FIG.24E

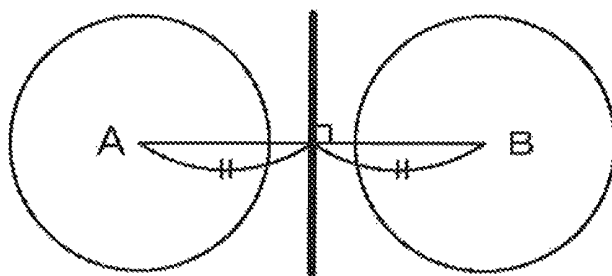

FIG. 25

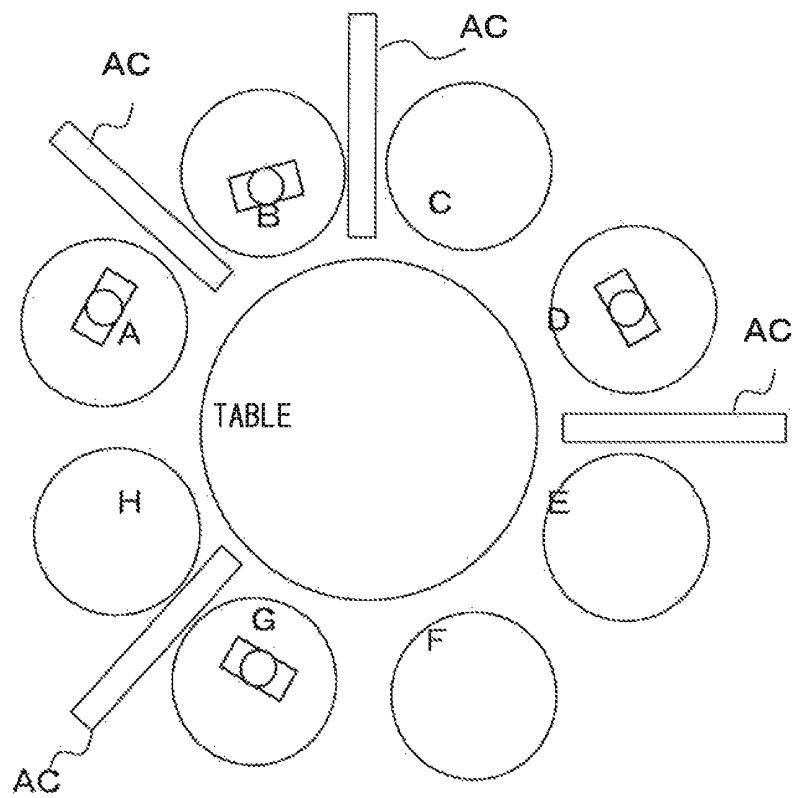

FIG.26A

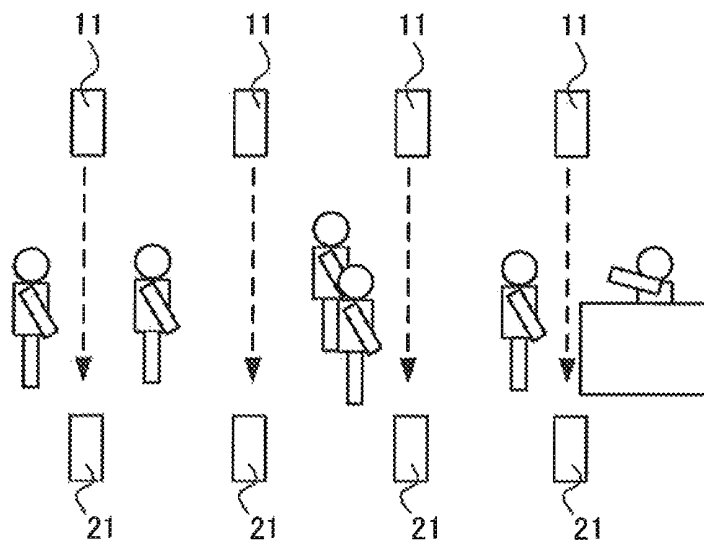

FIG.26B

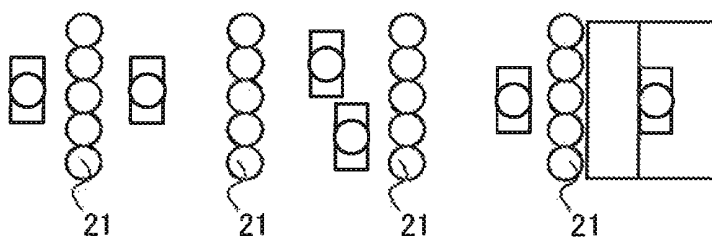

FIG.27

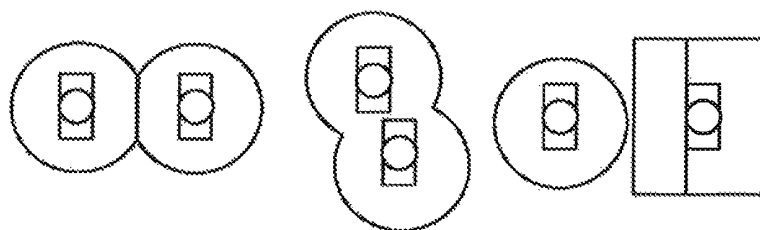

FIG.28

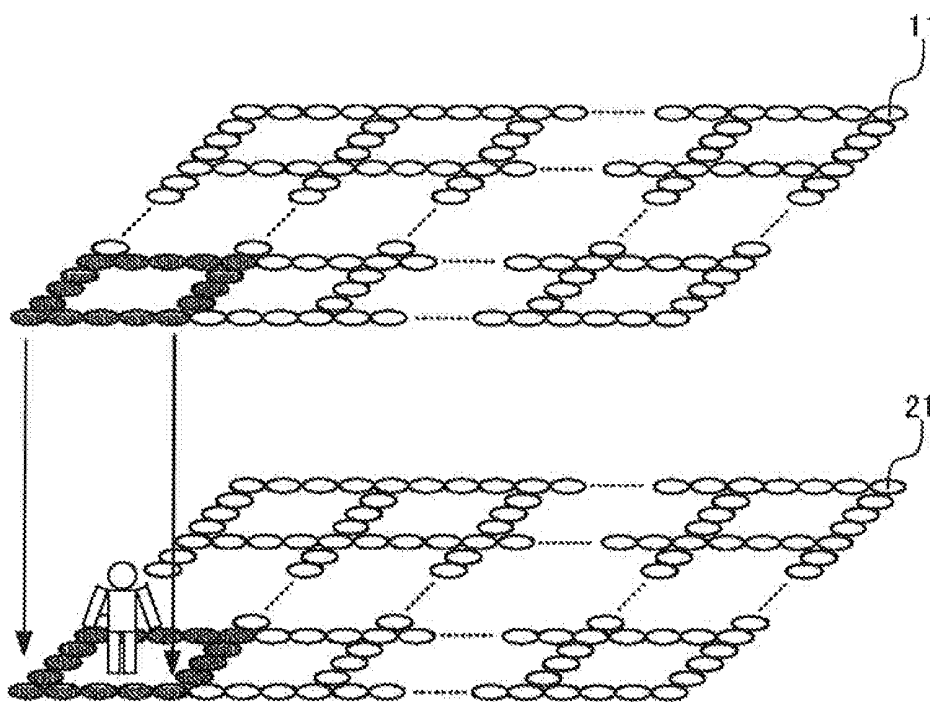

FIG. 29A

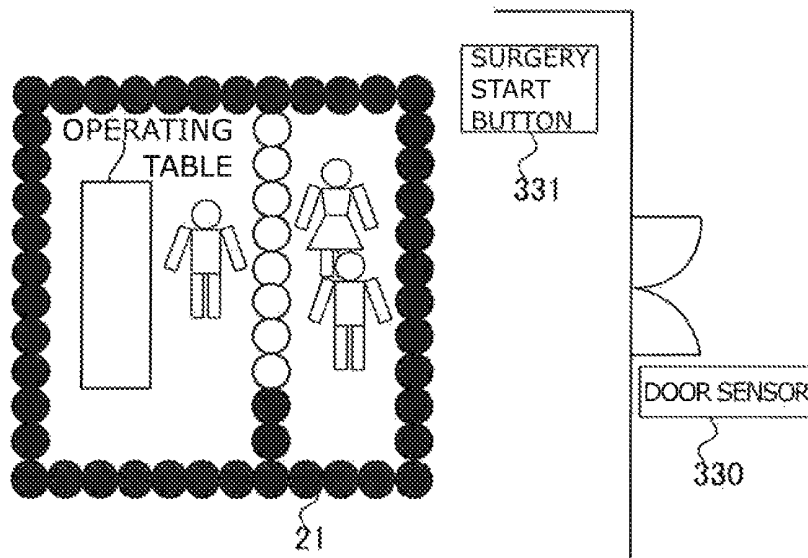

FIG. 29B

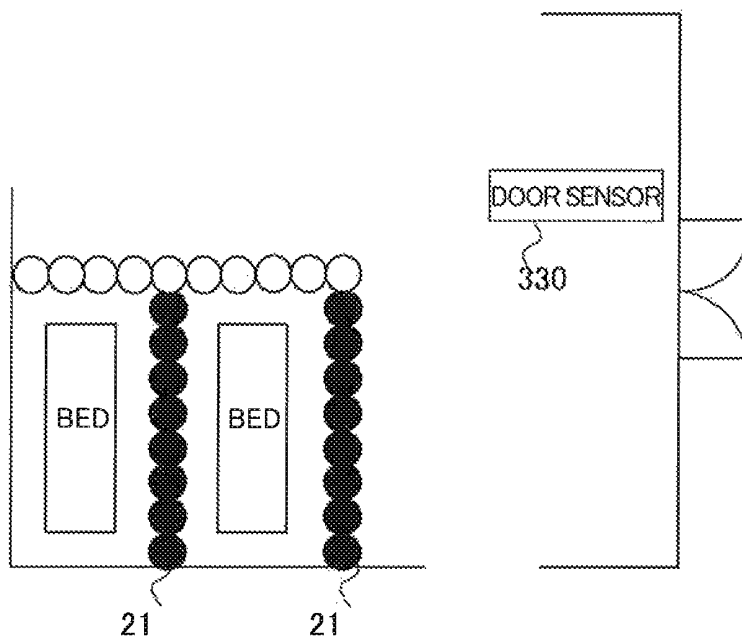

FIG.30A

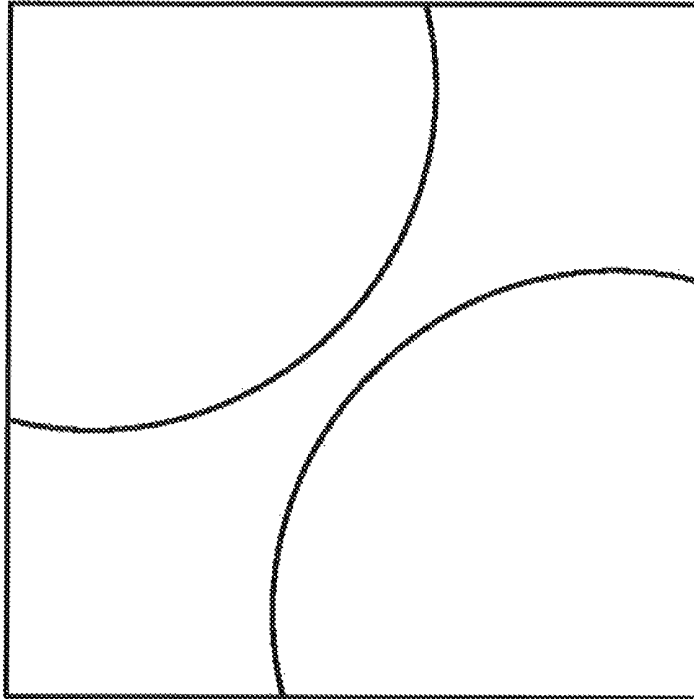

FIG.30B

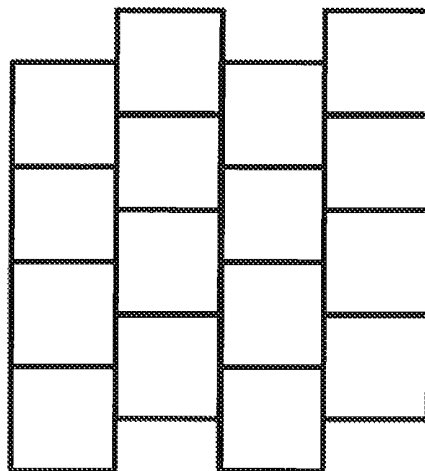
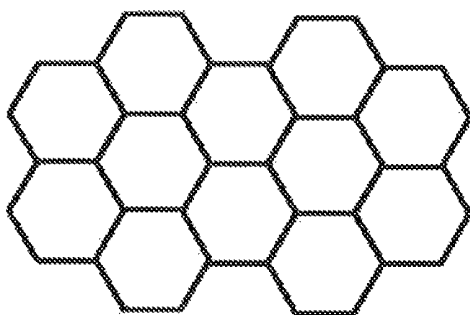

FIG.30C



AIR CURTAIN APPARATUS

TECHNICAL FIELD

The present invention relates to an air curtain apparatus that forms an air curtain.

BACKGROUND ART

In recent years, cases of pandemic viral or bacterial infectious diseases have been increasing. Examples of such infectious diseases include a new corona virus infection. In addition, in restaurants and other shops, as well as medical treatment facilities and nursing-care facilities, or the like, there are instances in which a plurality of persons face each other, have conversations, or eat and drink, with a short distance between each other. In such instances, and if one person is infected with the above-mentioned infectious disease, there is a risk that breathing, speech, coughing or sneezing or the like of that infected person disperses droplets such as saliva from the mouth of that infected person, and other person, more specifically, a person who faces that infected person may inhale from the nose or the mouth the droplets dispersed from that infected person.

As a method of preventing droplets from dispersing among a plurality of persons, it is desirable that when the plurality of persons face each other, or the like, all of them wear a mask. However, there are some instances where the plurality of persons is not able to wear a mask if conversations are difficult to hear while drinking and eating, for example, or in the case of identity confirmation. In addition, in a case where a shielding plate made of a glass or a resin or the like is installed between a plurality of persons, it may be difficult for the plurality of persons facing each other to have conversations in a quiet voice, for example, or impossible to hand over a good.

On the other hand, use of an air curtain apparatus instead of the shielding plate is conceivable that separates a certain space by belt-like air flow, more specifically, an air current, thereby dividing that space into two subspaces, and prevents entry of foreign matters such as droplets or the like from one subspace to the other subspace, for example,

In Japanese Unexamined Patent Application Publication No. 2011-137588 (Patent Literature 1), there is disclosed a technique of forming an air curtain between a first space and a second space, in a droplet blocking air curtain apparatus that is provided between the first space where a first person is present and the second space where a second person is present and that prevents movement of droplets between the first space and the second space, wherein the air curtain apparatus has columnar members that stand upright facing each other, one of the columnar members having an air blow port that discharges air zonally and the other of the columnar members having an intake port that sucks in air zonally.

In Japanese Unexamined Patent Application Publication No. 2011-30719 (Patent Literature 2), there is disclosed a technique of providing an air curtain generating unit that delivers an antibacterial air curtain to a predetermined position inside a storing part designated by a given command in an air curtain apparatus that delivers the air curtain to the inside of the storing part that accommodates people.

In Japanese Unexamined Patent Application Publication No. 2007-10184 (Patent Literature 3), there is disclosed a technique of forming an air barrier that circulates between a right housing and a left housing, by providing a plurality of pairs of air channels, in which an air outlet port is arranged on one side of and an air inlet port is arranged on the other

side of a surface where the right and left housings meet, in a gate-type air curtain including the housings, each of which holds the air outlet port and the air inlet port being erected and spaced apart to the right and left, and a top board connecting these housings. In the technique described in the above-mentioned Patent Literature 3, there is provided side-by-side a plurality of centrifugal fans units, the centrifugal fan unit including a motor, a centrifugal fan, a scroll or the like which are communicated with the air outlet port.

CITATION LIST

Patent Literature

- [PTL 1] Japanese Unexamined Patent Application Publication No. 2011-137588
 [PTL 2] Japanese Unexamined Patent Application Publication No. 2011-30719
 [PTL 3] Japanese Unexamined Patent Application Publication No. 2011-10184

SUMMARY OF THE INVENTION

Problems to be Solved by the Invention

In the techniques described in the above-mentioned Patent Literature 1 to Patent Literature 3, there is a problem that use of a large or complicated air curtain apparatus is necessary to efficiently separate and divide a certain space into two subspaces and to prevent entry of foreign matters such as droplets from one subspace to the other subspace, for example. In addition, there is another problem that use of such a large or complicated air curtain apparatus does not allow the air curtain apparatus to be easily installed or easily moved. In the technique described in Patent Literature 1, in particular, there is a problem that the columnar parts have to be positioned so that belt-like air discharged from the air blow port on the one columnar member is sucked in by the air intake port on the other columnar member, which does not allow for easy installation of the air curtain apparatus.

On the other hand, there is also a problem that simply using a small and simple air curtain apparatus does not make it possible to efficiently separate and divide a certain space, and to efficiently prevent entry of foreign matters from one subspace to the other subspace.

The present invention has been made in order to solve the above-mentioned problems of the prior-art. The present invention has an objective of providing an air curtain apparatus, wherein simply using a small and simple air curtain apparatus makes it possible to efficiently separate and divide a certain space and to efficiently prevent entry of foreign matters such as droplets from one subspace to the other subspace.

Means for Solving the Problems

A brief and schematic description of typical inventions disclosed in the present application, is given below:

An air curtain apparatus as one aspect of the present invention is an air curtain apparatus that forms an air curtain. The air curtain apparatus includes a plurality of first blowers being arrayed in an up-down direction and each including a first air inlet port in which air is sucked and a first air outlet port from which air is blown out; and a plurality of second blowers being arrayed in the up-down direction, each including a second air inlet port in which air is sucked and a second air outlet port from which air is blown out, and, in

a plan view, the second air inlet port each facing the first air outlet port included in each of the plurality of first blowers. In a pair of the first blower and the second blower, the first blower blows out a helical air current from the first air outlet port included in the first blower toward the second air inlet port included in the second blower, and the second blower sucks in the helical air current blown out by the first blower from the second air inlet port included in the second blower. In addition, the air curtain apparatus forms the air curtain of a plurality of the helical air currents, the plurality of helical air currents being blown out from the plurality of first air outlet ports each included in each of the plurality of first blowers and sucked into the plurality of second air inlet ports each included in each of the plurality of second blowers.

In addition, as another aspect, a third blower, which is any of the plurality of first blowers, may include a light emitting unit. The light emitting unit emits light in a direction in which the helical air current is blown out of the first air outlet port included in a third blower. Relative positions of the plurality of second blowers with respect to the plurality of first blowers may be adjusted so that light applied by the light emitting unit is applied to a fourth blower. The fourth blower is any of the plurality of second blowers and, in a plan view, includes the second air inlet port facing the first air outlet port included in the third blower.

In addition, as another aspect, the light emitting unit may be a laser or a light emitting diode that emits visible light or infrared light.

In addition, as another aspect, the fourth blower may also include a light receiving unit that receives light applied by the light emitting unit. Relative positions of the plurality of second blowers with respect to the plurality of first blowers may be adjusted so that light applied by the light emitting unit is applied to the light receiving unit.

In addition, as another aspect, the air curtain apparatus includes two air curtain forming units, each of which forms an air curtain. Each of the two air curtain forming units may have a plurality of first blowers and a plurality of second blowers. The plurality of second blowers held by a first air curtain forming unit, which is any of the two air curtain forming units, in a plan view, may be adjacent to the plurality of first blowers held by a second air curtain forming unit, which is different from the first air curtain forming unit of the two air curtain forming units. In a plan view, a direction from the plurality of first blowers held by the second air curtain forming unit toward the plurality of second blowers held by the second air curtain forming unit may differ from a direction from the plurality of first blowers held by the first air curtain forming unit toward the plurality of second blowers held by the first air curtain forming unit. The first air curtain forming unit may have a first connection unit that connects the plurality of second air outlet ports and the plurality of first air inlet ports in an airtight manner, each of the plurality of second air outlet ports being included in each of the plurality of second blowers held by the first air curtain forming unit, and each of the plurality of first air inlet ports being included in each of the plurality of first blowers held by the second air curtain forming unit.

In addition, as another aspect, the air curtain apparatus may include N air curtain forming units (N being an integer of 3 or larger), the air curtain forming units being arrayed along an annular path around a central axis along the up-down direction and each forming an air curtain. Each of the N air curtain forming units may have a plurality of first blowers and a plurality of second blowers. For each of the N air curtain forming units, in a pair of a third air curtain forming unit and a fourth air curtain forming unit, in a plan

view, the plurality of second blowers held by the third air curtain forming unit may be adjacent to a plurality of first blowers held by the fourth air curtain forming unit, the third air curtain forming unit being the air curtain forming unit, and the fourth air curtain forming unit, of the N air curtain forming units, being arranged on a first side which is, in a plan view, side of an anti-clockwise direction or that of a clockwise direction, along the annular path of the third air curtain forming unit, and the fourth air curtain forming unit being the air curtain forming unit adjacent to the third air curtain forming unit. The third air curtain forming unit may have a second connection unit that connects in an air-tight manner the plurality of second air outlet ports and the plurality of first air inlet ports in an airtight manner, the plurality of second air outlet ports each being included in each of the plurality of second blowers held by the third air curtain forming unit and the plurality of first air inlet ports each being included in each of the plurality of first blowers held by the fourth air curtain forming unit.

In addition, as another aspect, a rotation direction of the helical air current, when the helical air current blown out by the first blower is seen from the first blower, is a clockwise or anti-clockwise rotation direction, and may be the same rotation direction among the plurality of first blowers.

In addition, as another aspect, each of the plurality of first blowers includes a first cylinder part and a first fan provided inside the first cylinder part. The first air inlet port is provided at a first end in an axial direction of the first cylinder part. The first air outlet port is provided at a second end opposite to the first end, in the axial direction of the first cylinder part. The first fan may suck in air from the first air inlet port and blow out from the first air outlet port the air sucked in from the first air inlet port. Each of the plurality of first blowers may further include a first grille, the first grille being provided at the first air outlet port and having a plurality of holes formed therein, each having a helical shape swirling in a clockwise or anti-clockwise direction when viewed from the direction of the first cylinder part.

In addition, as another aspect, each of the plurality of first blowers may have a spraying unit that sprays an antiseptic solution inside the first cylinder part.

In addition, as another aspect, each of the plurality of second blowers includes a second cylinder part and a second fan provided inside the second cylinder part. The second air inlet port is provided at a third end in the axial direction of the second cylinder part. The second air outlet port is provided at a fourth end which is opposite to the third end in the axial direction of the second cylinder part. The second fan may suck in air from the second air inlet port and blow out from the second air outlet port the air sucked from the second air inlet port. An inner diameter of the second air inlet port may be larger than that of the first air outlet port.

In addition, as another aspect, each of the plurality of first blowers may include a first injection unit that injects a colored gas into the inside of the first cylinder part.

In addition, as another aspect, each of the plurality of first blowers may include a second injection unit that injects a gas containing a smell component into the inside of the first cylinder part.

In addition, as another aspect, at least any one of the first blower and the second blower further includes an identification member that makes it possible to visually identify a traveling direction of the helical air current. The identification member includes a strip-shaped member, a storing part that stores the strip-shaped member in a rolled-up state, and a placement part in which the strip-shaped member is drawn from the storing part is placed. In a case where the strip-

shaped member is drawn from the storing part, the strip-shaped member may be maintained in a state in which it is extended along the traveling direction of the helical air current.

According to this aspect, it is possible to judge the traveling direction of the helical air current by visually inspecting the identification member. For example, because it is possible to judge the traveling direction of the helical air current of the first blower, positioning of the air curtain apparatus completes by placing the second blower at a position along that traveling direction. In this manner, it becomes possible to provide the air curtain apparatus that is easy to install.

In addition, according to this aspect, the traveling direction of the helical air current may be judged by drawing the strip-shaped member from the storing part, placing it in the placement part, and visually inspecting a direction in which the strip-shaped member extends from the storing part. Therefore, for example, because it is possible to judge the traveling direction of the helical air current of the first blower, positioning of the air curtain apparatus completes by placing the second blower at a position along the traveling direction. In this manner, it becomes possible to provide the air curtain apparatus that is easy to install.

In addition, as another aspect, at least any one of the first blower and the second blower further includes an identification member that makes it possible to visually identify the traveling direction of the helical air current. The identification member includes a strip-shaped member, being deformable in any of an elongated state in which a plurality of short members is connected and a folded state; and a placement part in which a predetermined region of the strip-shaped member in the elongated state is placed. The strip-shaped member may extend along the traveling direction of the helical air current in the elongated state.

According to this aspect, it is possible to judge the traveling direction of the helical air current by deforming the plurality of short members of the strip-shaped member into the elongated state, placing them in the placement part, and visually inspecting a direction in which the strip-shaped member extends from the storing part. Therefore, for example, because it is possible to judge the traveling direction of the helical air current of the first blower, positioning of the air curtain apparatus completes by placing the second blower at a position along the traveling direction. In this manner, it becomes possible to provide the air curtain apparatus that is easy to install.

In addition, as another aspect, at least any one of the first blower and the second blower further includes an identification member that makes it possible to visually identify the traveling direction of the helical air current. The identification member includes a stretchable member having a plurality of cylindrical members of varying diameters arranged concentrically, and a placement part where a predetermined region of the stretchable member in a stretched state is placed. The stretchable member may also extend along the traveling direction of the helical air current in the stretched state.

According to this aspect, it is possible to judge the traveling direction of the helical air current by stretching the stretchable member, placing it in the placement part, and visually inspecting a direction in which the stretchable member extends from the storing part. Therefore, for example, because it is possible to judge the traveling direction of the helical air current of the first blower, positioning of the air curtain apparatus completes by placing the second blower at a position along the traveling direction. In this

manner, it becomes possible to provide the air curtain apparatus that is easy to install.

In addition, as another aspect, at least any one of the first blower and the second blower further includes an identification member that makes it possible to visually identify the traveling direction of the helical air current. The identification member may also include a scope unit that is arranged in one of the first blower and the second blower and is able to visually recognize an object present in a direction along the traveling direction of the helical air current.

According to this aspect, it is possible to judge the traveling direction of the helical air current by looking into the scope unit. Therefore, for example, because it is possible to judge the traveling direction of the helical air current, positioning of the air curtain apparatus completes by placing the second blower at a position along that traveling direction. In this manner, it becomes possible to provide the air curtain apparatus that is easy to install.

In addition, as another aspect, at least any one of the first blower and the second blower further includes an identification member that makes it possible to visually identify the traveling direction of the helical air current. The identification member includes an elongated bag-shaped member a base end of which is opened and a termination of which is closed; and a linear spring member fixed to the bag-shaped member and deforming the bag-shaped member into a wrapped state. The bag-like member is arranged so that the base end faces the first blower and may extend along the traveling direction of the helical air current by air from the first blower flowing in from the base end.

According to this aspect, because air that drives the first blower flows into the bag-shaped member, the bag-shaped member extends along the traveling direction of the helical air current. This makes it possible to judge the traveling direction of the helical air current. Therefore, for example, because it is possible to judge the traveling direction of the helical air current of the first blower, positioning of the air curtain apparatus completes by placing the second blower at a position along the traveling direction. In this manner, it becomes possible to provide the air curtain apparatus that is easy to install.

In addition, as another aspect, there may be an aspect having a controller that drives and controls the first blower and the second blower. This another aspect has the controller, and a controller that drives and controls the first blower and the second blower. The plurality of first blowers is juxtaposed in an upper part of an indoor space, and the plurality of second blowers is juxtaposed in a lower part of an indoor space. In the plurality of first blowers and the plurality of second blowers, the controller may select a plurality of predetermined pairs, the predetermined pairs being pairs of predetermined first blowers of the plurality of first blowers and the second blowers facing the predetermined first blowers, and may drive and control the selected first blowers and second blowers.

According to this aspect, by the controller performing driving and control of the plurality of first blowers and the plurality of second blowers to select and drive the first blower and the second blower to be driven, it is possible to form air curtains of various patterns at various positions.

In addition, as another aspect, the aspect having the controller further has a position sensing apparatus that senses a position of a mobile object in the indoor space. The controller may obtain positional information of a mobile object from the position sensing apparatus, select the plurality of the predetermined pairs that are located at a certain

distance from the mobile object, and drive and control the first blower and the second blower that constitute the selected predetermined pairs.

According to this aspect, by the controller performing driving and control of the plurality of first blowers and the plurality of second blowers, and selecting and driving the first blower and the second blower to be driven on the basis of a position of the mobile object, it becomes possible to form an air curtain of a suitable pattern at a position suitable for the mobile object.

In addition, as another aspect, in an aspect having the controller and the position sensing apparatus, the plurality of first blowers and the plurality of second blowers may be arranged in a matrix in the indoor space.

According to this aspect, it becomes possible to form an air curtain of various patterns such as an air curtain having a near-circular pattern, for example.

In addition, as another aspect, in an aspect in which the plurality of second blowers is arranged in a matrix in the indoor space, the controller may select a plurality of the predetermined pairs located in a predetermined radius from the mobile object, and form a cylindrical air curtain surrounding the mobile object.

According to this aspect, in order to form the cylindrical air curtain surrounding the mobile object,

In addition, as another aspect, in the aspect having the controller and the position sensing apparatus, the plurality of first blowers and the plurality of second blowers may be arranged in a grid pattern in the indoor space.

According to this aspect, it becomes possible to form an air curtain having various patterns, like an air curtain having a linear or rectangular tubular pattern, for example.

In addition, as another aspect, in an aspect in which the second blowers are arranged in a grid pattern in the indoor space, the controller may be able to collectively select the plurality of first blowers and the plurality of second blowers aligned on an individual line of four lines that form one grid.

According to this aspect, the controller is able to control the plurality of first blowers and the plurality of second blowers in units of a grid line, thereby reducing processing load of the controller.

In addition, as another aspect, in an aspect having the controller and the position detecting apparatus, the controller may form an air curtain surrounding a plurality of mobile objects in a case where the plurality of mobile objects sensed by the position sensing apparatus mutually has a group relationship, and a distance between the respective mobile objects is closer than a predetermined distance.

According to this aspect, in a case where the plurality of mobile object mutually has the group relationship, it becomes possible to separate the plurality of mobile objects together by one air curtain, rather than forming an air curtain individually.

In addition, as another aspect, in the aspect having the controller and the position sensing apparatus, the controller may update the positional information for every predetermined period, and select the plurality of predetermined pairs on the basis of the updated positional information.

According to this aspect, it becomes possible to move an air curtain so as to follow a mobile object as the mobile object moves.

In addition, as another aspect, in the aspect having the controller and the position sensing apparatus, the controller may select the plurality of predetermined pairs, the predetermined pairs being able to configure an air curtain that separates only a specific mobile object in a case where there is the specific mobile object for one or more mobile objects

located at a position corresponding to the positional information obtained by the position sensing apparatus. The controller may drive and control the first blower and the second blower that constitute the selected predetermined pair. The second blower may suck in, from the second air inlet port included in the second blower, the helical air current blown out from the first blower located vertically above.

In addition, as another aspect, an aspect having the controller and the position sensing apparatus and being able to configure the air curtain that separates only the specific mobile object may further have guide means that is able to guide to a specific position in the certain space with respect to the specific mobile object.

In addition, as another aspect, the aspect having the controller may further have marker means that is able to notify a position that differs from a position of an air curtain formed in a direction from the first blower to the second blower, the first blower and the second blower being selected by the controller.

Effect of the Invention

With one aspect of the present invention applied, simply using a small and simple air curtain apparatus makes it possible to efficiently separate and divide a certain space and to efficiently prevent entry of foreign matters such as droplets or the like from one subspace to the other subspace.

BRIEF DESCRIPTION OF DRAWINGS

FIG. 1 is a diagram schematically illustrating a configuration of an air curtain apparatus of an embodiment.

FIG. 2 is a cross-sectional diagram schematically illustrating the air curtain apparatus of the embodiment.

FIG. 3 is a top view schematically illustrating an example of arrangement of the air curtain apparatus of the embodiment.

FIG. 4 is a top view schematically illustrating another example of the arrangement of the air curtain apparatus of the embodiment.

FIG. 5 is a diagram schematically illustrating a configuration of the air curtain apparatus of the embodiment.

FIG. 6 is a top view schematically illustrating a configuration of an air curtain apparatus of a first modification example of the embodiment.

FIG. 7 is a top view schematically illustrating a configuration of an air curtain apparatus of a second modification example of the embodiment.

FIG. 8 is a top view schematically illustrating a configuration of an air curtain apparatus of the third modification example of an embodiment.

FIG. 9 is a top view schematically illustrating a configuration of an air curtain apparatus of a fourth modification example of the embodiment.

FIG. 10 is a top view schematically illustrating a configuration of an air curtain apparatus of a fifth modification example of the embodiment.

FIG. 11A is a perspective view schematically illustrating a configuration of a blower 11 according to an air curtain apparatus of a sixth modification example of the embodiment.

FIG. 11B is a lateral view schematically illustrating a configuration of the blower 11 according to the air curtain apparatus of the sixth modification example of the embodiment.

FIG. 12A is a perspective view illustrating another configuration 1 of an identification apparatus 80 in the sixth modification example.

FIG. 12B is a lateral view illustrating the other configuration 1 of the identification apparatus 80 in the sixth modification example.

FIG. 13A is a lateral view illustrating another configuration 2 of the identification apparatus 80 in the sixth modification example.

FIG. 13B is a lateral view illustrating a state prior to use of the other configuration 2 of the identification apparatus 80 in the sixth modification example.

FIG. 14A is a lateral view illustrating another configuration 3 of the identification apparatus 80 in the sixth modification example.

FIG. 14B is a lateral view illustrating a state prior to use of the other configuration 3 of the identification apparatus 80 in the sixth modification example.

FIG. 15A is a lateral view illustrating another configuration 4 of the identification apparatus 80 in the sixth modification example.

FIG. 15B is a lateral view illustrating a state of use of the other configuration 4 of the identification apparatus 80 in the sixth modification example.

FIG. 15C is a lateral view illustrating the state of use of the other configuration 4 of the identification apparatus 80 in the sixth modification example.

FIG. 16 is a perspective view illustrating an example of a configuration in which the identification apparatus 80 illustrated in FIG. 11 is combined with the identification apparatus 80 illustrated in FIG. 12.

FIG. 17 is a perspective view illustrating an example of a configuration in which the identification apparatus 80 illustrated in FIG. 11 is attached to each of a plurality of blowers 11 in an air outlet unit 3.

FIG. 18 is an explanatory diagram schematically illustrating a skeleton framework of a seventh modification example.

FIG. 19 is a flow chart illustrating an example of preferred flow of a ventilation process to be performed in a controller 200 according to the seventh modification example.

FIG. 20 is an explanatory diagram schematically illustrating a utilization example 1 in which the seventh modification example is utilized in an elevator.

FIGS. 21A-21F are top views illustrating air curtain patterns in the utilization example 1.

FIG. 22 is an explanatory diagram schematically illustrating a utilization example 2 in which the seventh modification example is utilized in a large hall such as a party space, a banquet hall, and an exhibition space.

FIG. 23 is an explanatory diagram illustrating an example of air curtain formation in the utilization example 2.

FIG. 24A is an explanatory diagram illustrating an example of air curtain formation in the utilization example 2 in which there are two persons.

FIG. 24B is an explanatory diagram illustrating an example of air curtain formation in the utilization example 2 in which there are two persons.

FIG. 24C is an explanatory diagram illustrating an example of air curtain formation in the utilization example 2 in which there are two persons.

FIG. 24D is an explanatory diagram illustrating an example of air curtain formation in the utilization example 2 in which there are three persons.

FIG. 24E is an explanatory diagram illustrating an example of air curtain formation in the utilization example 2 in which there are two persons.

FIG. 25 is an explanatory diagram illustrating another example of air curtain formation in the utilization example 2.

FIG. 26A is a lateral view schematically illustrating a utilization example 3 in which the seventh modification example is used in a place, such as a cash desk or a ticket box office, where people line up.

FIG. 26B is a top view schematically illustrating the utilization example 3 in which the seventh modification example is used in a place, such as a cash desk or a ticket box office, where people line up.

FIG. 27 is an explanatory diagram illustrating an example of air curtain formation in the utilization example 3.

FIG. 28 is an explanatory diagram illustrating another example of arrangement of the blowers 11 and blowers 21 on a ceiling and a floor.

FIG. 29A is an explanatory diagram schematically illustrating a utilization example 4 in which the seventh modification example is used in a hospital.

FIG. 29B is an explanatory diagram schematically illustrating the utilization example 4 in which the seventh modification example is used in the hospital.

FIG. 30A is an explanatory diagram schematically illustrating the other example of arrangement of the blowers 11 and the blowers 21 on the ceiling and the floor.

FIG. 30B is an explanatory diagram schematically illustrating the other example of arrangement of the blowers 11 and the blowers 21 on the ceiling and the floor.

FIG. 30C is an explanatory diagram schematically illustrating the other example of arrangement of the blowers 11 and the blowers 21 on the ceiling and the floor.

MODES FOR CARRYING OUT THE INVENTION

In the following, a description is given of an embodiment and respective modification examples of the present invention, with reference to the drawings.

It is to be noted that the disclosure is merely an example, and that those modifications of which those skilled in the art may easily conceive, where appropriate, while maintaining the gist of the present invention shall be naturally included in the scope of the present invention. In addition, in order to clarify the description, while drawings may be schematically depicted in terms of a width, a thickness, a shape, of the like, as compared with the embodiment, they are merely an example, and shall not limit any interpretation of the present invention.

In addition, in the specification and respective figures, same components as those described in relation to the above-mentioned drawings may be designated by the same reference numerals, and a detailed description thereof may be omitted where appropriate.

Furthermore, in the drawings used in the embodiment, hatching may be omitted to make the drawings easier to see, even though they are cross-sectional diagrams. In addition, hatching may be added to even a top view to make it easier to see.

It is to be noted that in the following embodiment, in a case where a range is denoted as A to B, the range shall represent A or larger and B or smaller, unless otherwise specified.

<Air Curtain Apparatus>

A description is given of an air curtain apparatus according to an embodiment which is one embodiment of the present invention. FIG. 1 is a diagram schematically illustrating a configuration of an air curtain apparatus of the embodiment. FIG. 2 is a cross-sectional diagram schematically illustrating the configuration of the air curtain apparatus of the embodiment. FIG. 3 is a top view schematically illustrating an example of arrangement of the air curtain apparatus of the embodiment. FIG. 4 is a top view schematically illustrating another example of the arrangement of the air curtain apparatus of the embodiment. FIG. 5 is a diagram schematically illustrating the configuration of the air curtain apparatus of the embodiment. Note that FIG. 2 represents a pair formed by one (one unit) of a blower 11 and one (one unit) of a blower 21, of an air curtain 1 illustrated in FIG. 1. In addition, in FIG. 2, a part of an air curtain AC1 is depicted as an air curtain AC10. In addition, in FIG. 1, FIG. 2, and FIG. 5, an arrow represents a direction of an air current (the same also applies to FIG. 6 and FIG. 8 to FIG. 10).

As illustrated in FIG. 1 and FIG. 2, the air curtain apparatus 1 of the present embodiment is an air curtain apparatus that forms an air curtain, and includes an air curtain forming unit 2 that forms an air curtain. The air curtain forming unit 2 includes an air outlet unit 3 from which air is blown out and an air inlet unit 4 from which air is sucked in. The air curtain forming unit 2 forms an air curtain AC1 of a plurality of helical air currents SA1, the helical air currents SA1 being blown out from the air outlet unit 3 and sucked into the air inlet unit 4.

The air outlet unit 3 has a plurality of vertically arrayed blowers (circulators) 11 and a support part (stand) 12 that supports the plurality of blowers 11. Each of the plurality of blowers 11 includes an air inlet port 13 in which air is sucked and an air outlet port 14 from which air is blown out. For example, the support 12 including a leg 15 and a frame part 16 provided on the leg 15 may be used, although the support 12 is not specifically limited thereto. In such a case, each of the plurality of blowers 11 is fixed by the frame part 16 in a vertically arrayed state or is supported by the frame part 16, while being arrayed vertically and in a state in which a direction of the air outlet port 14 is changeable. In addition, it is possible to easily install or move the air outlet unit 3 by grasping and carrying the frame part 16.

The air inlet unit 4 has a plurality of vertically arrayed blowers (circulators) 21 and a support part (stand) 22 that supports the plurality of blowers 21. Each of the plurality of blowers 21 includes an air inlet port 23 in which air is sucked and an air outlet port 24 from which air is blown out. In addition, in a plan view, the plurality of blowers 21 is arranged so that the air inlet port 23 respectively faces the air outlet port 14 included in each of the plurality of blowers 11. For example, the support 22 including a leg 25 and a frame part 26 provided on the leg 25 may be used, although the support 22 is not specifically limited thereto. In such a case, each of the plurality of blowers 21 is fixed to the frame part 26 in a vertically arrayed state, or is supported by the frame part 26 while being arrayed vertically and in a state in which a direction of the air inlet port 23 is changeable. In addition, it is possible to easily install or move the air inlet unit 4 by grasping and carrying the frame part 26.

Specifically, each of the plurality of blowers 11 is able to include a cylinder part 32 centering around a central axis 31, a fan 33 rotatably provided inside the cylinder part 32

around the central axis 31, and a drive unit 34 that rotates and drives the fan 33. In such a case, the air inlet port 13 is provided at an end 35 in a direction along the central axis 31 of the cylinder part 32, more specifically, in an axial direction, and the air outlet port 14 is provided at an end 36 opposite to the end 35, in the direction along the central axis 31 of the cylinder part 32, more specifically, in the axial direction. The fan 33 sucks in air from the air inlet port 13 and blows out, from the air outlet port 14, the air sucked in from the air inlet port 13.

In addition, each of the plurality of blowers 21 is able to include a cylinder part 42 centering around a central axis 41, a fan 43 rotatably provided inside the cylinder part 42 around the central axis 41, and a drive unit 44 that rotates and drives the fan 43. In such a case, the air inlet port 23 is provided at an end 45 in a direction along the central axis 41 of the cylinder part 42, more specifically, in an axial direction, and the air outlet port 24 is provided at an end 46 opposite to the end 45, in the direction along the central axis 41 of the cylinder part 42, more specifically, in the axial direction. The fan 43 sucks in air from the air inlet port 23 and blows out, from the air outlet port 24, the air sucked in from the air inlet port 23.

In the present embodiment, for each of the plurality of blowers 11, a pair is formed by the blower 11 and the blower 21, the blower 21 being any of the plurality of blowers 21 and including the air inlet port 23 that faces the air outlet port 14 included in the blowers 11.

In the air of the blower 11 and the blower 21, the blower 11 blows out the helical air current SA1 from the air outlet port 14 included in the blower 11 toward the air inlet port 23 included in the blower 21. In addition, in the pair of the blower 11 and the blower 21, the blower 21 sucks in, from the air inlet port 23 included in the blower 21, the helical air current SA1 blown out by the blower 11 from the air outlet port 14 included in the blower 11 toward the air inlet port 23 included in the blower 21.

The air curtain apparatus 1 of the present embodiment is arrayed in the up-down direction, and forms the air curtain AC1 with the plurality of helical air currents SA1, the helical air currents SA1 each being blown out from each of the plurality of air outlet ports 14 included in each of the plurality of blowers 11 and the helical air currents SA1 each being sucked in each of the plurality of air inlet ports 23 each included in each of the plurality of blowers 21. The plurality of helical air currents SA1 forms the air curtain AC1.

Here, a description is given of problems in forming an air curtain by the air curtain apparatus.

In the techniques described in the above-mentioned Patent Literature 1 to 3, there is a problem that use of a large or complicated air curtain apparatus is necessary to efficiently separate and divide a certain space into two subspaces and to prevent entry of foreign matters such as droplets from one subspace to the other subspace, for example. There is another problem that use of such a large or complicated air curtain apparatus does not allow the air curtain apparatus to be easily installed or easily moved.

Moreover, there is also a problem that simply using a small and simple air curtain apparatus does not make it possible to efficiently separate and divide a certain space, and to efficiently prevent entry of foreign matters from one subspace to the other subspace.

On the other hand, the air curtain apparatus 1 of the present embodiment includes a plurality of vertically arrayed blowers 11 and a plurality of vertically arrayed blowers 21, wherein the air inlet ports 23 included in the blowers 21 face the air outlet ports 14 included in the

blowers **11**. In addition, in the pair of the blower **11** and the blower **21**, the blower **11** blows out the helical air current SA1 from the air outlet port **14** included in the blower **11** toward the air inlet port **23** included in the blower **21**, and the blower **21** sucks in, from the air inlet port **23**, the helical air current SA1 blown out by the blower **11**. In addition, the air curtain apparatus **1** of the present embodiment forms the air curtain AC1 with the plurality of helical air currents SA1, the helical air currents SA1 being blown from the plurality of air outlet ports **14** included in the plurality of blowers **21** and being sucked in the plurality of air inlet ports **23** each included in each of the plurality of blowers **21**.

In a case where the helical air current SA1 having a helical shape is blown out from the air outlet port **14**, the air current does not spread and goes straight more easily than a case where an air current having any shape other than the helical shape is blown out. That is to say, straightness of the helical air current SA1 is higher than that of the air current having any shape other than the helical shape.

Consequently, the plurality of helical air currents SA1 being blown from the plurality of air outlet ports **14** each included in each of the plurality of vertically arrayed blowers **11**, more specifically, the plurality of vertically arrayed air outlet ports **14**, it is possible to prevent or suppress a thickness of the air curtain AC1 from increasing as the air curtain AC1 moves away from the plurality of blowers **11**.

In addition, the plurality of helical air currents SA1 each blown out from each of the plurality of air outlet ports **14** being sucked in the plurality of air inlet ports **23** each included in each of the plurality of vertically arrayed blowers **21**, more specifically, the plurality of vertically arrayed air inlet ports **23**, it is possible to prevent or suppress the thickness of the air curtain AC1 from increasing as the air curtain AC1 moves away from the plurality of blowers **11**.

Consequently, according to the air curtain apparatus **1** of the present embodiment, simply using the small and simple air curtain apparatus makes it possible to efficiently separate and divide a certain space and efficiently prevent entry of foreign matters such as droplets or the like from one subspace to the other subspace. Moreover, because use of the large or complicated air curtain apparatus is not necessary to efficiently separate and divide a certain space into two subspaces and prevent entry of foreign matters such as droplets or the like from one subspace to the other subspace, it is possible to easily install and easily move the air curtain apparatus.

That is to say, according to the air curtain apparatus **1** of the present embodiment, it is possible to efficiently separate and divide a certain space, to efficiently prevent entry of foreign matters such as droplets or the like from one subspace to the other subspace, and to easily install and easily move the air curtain apparatus.

As illustrated in FIG. 3, the air curtain apparatus **1** of the present embodiment is a small and simple air curtain apparatus and may therefore be installed on a table **51**, for example. For example, in a restraint and other shops, for example, in a case where two users **52** face each other with the table in between or where the user **52** faces an employee **53**, it is possible to efficiently separate and divide a space SP centering around the table **51** into two subspaces SP1 and SP2 between the two users **52** or between the user **52** and the employee **53**.

In such a case, as described above, it is not necessary to install a shielding plate made of a glass, a resin or the like between the two users **52** or between the user **52** and the employee **53**. Therefore, the two users **52** or the user **52** and

the employee **53** may easily have conversations in a quiet voice, for example, or hand over a good.

As illustrated in FIG. 4, because the air curtain apparatus **1** of the present embodiment is a small and simple air curtain apparatus, it is possible to install the air curtain apparatus **1** between a table group **54** including a plurality of tables **51** and a table group **55** including a plurality of the tables **51**. Even in a case where there is an aisle **56** between the table group **54** and the table group **55** and it is difficult to install a shielding plate made of a glass, a resin, or the like on that aisle **56**, installation of the air curtain apparatus **1** of the present embodiment on the aisle **56** between the table group **54** and the table group **55** makes it possible to efficiently separate and divide a space SP where a plurality of the tables **51** is located in two subspaces SP1 and SP2 with the aisle **56** as a boundary. Note that the plurality of tables **51** included in the table group **54** is arrayed along the aisle **56** so that the tables **51** and partitions **57** are alternately arranged, and that the plurality of tables **51** included in the table group **55** are arrayed along the aisle **56** so that the tables **51** and the partitions **57** are alternately arranged.

In addition, as described above, straightness of the helical air current SA1 is higher than that of the air current having any shape other than the helical shape. Consequently, according to the air curtain apparatus **1** of the present embodiment, as illustrated in FIG. 4, one air curtain apparatus **1** is able to efficiently separate and divide the table group **54** and the table group **55**, the table group **54** including the three tables **51** that are arranged in the one subspace SP1 and arrayed along the aisle **56**, and the table group **55** including the three tables **51** that are arranged in the other subspace SP2 and arrayed along the aisle **56**.

As illustrated in FIG. 5, preferably, a blower **11a**, which is any (or all) of the plurality of blowers **11**, includes a light emitting unit **61**, the light emitting unit **61** applying light LG1 to a direction in which the helical air current SA1 is blown out from the air outlet port **14** included in the blower **11a**. In addition, relative positions of the plurality of blowers **21** with respect to the plurality of blowers **11** are adjusted so that the light LG1 applied by the light emitting unit **61** included in the blower **11a** is applied to a blower **21a**, the blower **21a** being any (or all) of the plurality of blowers **21** and including the air inlet port **23** that, in a plan view, faces the air outlet port **14** included in the blower **11a**.

In such a case, in a location where the air curtain apparatus **1** of the present embodiment is installed, it is possible to confirm easily and visually whether or not the helical air current SA1 blown out from the air outlet port **14** of the blower **11** reaches straight the air inlet port **23** of the blower **21** (whether or not it arrives) by adjusting the relative position of the air inlet unit **4** with respect to the air outlet unit **3**, while irradiating the blower **21a** with the light applied by the light emitting unit **61** included in the blower **11a**.

It is to be noted that as for the light emitting unit **61**, the blower **11** and the blower **21** may be reversed. That is to say, the blower **21a**, which is any (or all) of the plurality of blowers **21** may also include a light emitting unit (not illustrated) that applies light in a direction in which the helical air current SA1 is sucked into the air inlet port **23** included in the blower **21a**. In addition, the relative positions of the plurality of blowers **11** with respect to the plurality of blowers **21** may be adjusted so that the light applied by the light emitting unit (not illustrated) included in the blower **21a** is applied to the blower **11a**, the blower **11a** being any (or all of) the plurality of blowers **11** and including the air outlet port **14** that faces the air inlet port **23** included in the blower **21a**.

Preferably, the light emitting unit **61** included in the blower **11** is a laser or a light emitting diode that emits visible light or infrared light as the light LG1.

The straightness of the light applied by the laser or the light emitting diode is higher than that of light applied by any other light source. Consequently, the light emitting unit **61** being the laser or the light emitting diode that emits visible light or infrared light further makes it possible to confirm visually and easily whether or not the helical air current SA1 blown out from the air outlet port **14** of the blower **11** reaches straight the air inlet port **23** of the blower **21** (whether or not it arrives). Therefore, it is further possible to ensure that the blower **11** is reliably associated with the blower **21** on a one-to-one basis.

Preferably, the blower **21a** includes a light receiving unit **62**, the light receiving unit **62** receiving the light applied by the light emitting unit **61** included in the blower **11a**. In addition, the relative positions of the plurality of blowers **21** with respect to the plurality of blowers **11** are adjusted so that the light applied by the light emitting unit **61** included in the blower **11a** is applied to the light receiving unit **62** included in the blower **21a**. As the light receiving unit **62**, a smooth plate portion, for example, having a high reflectance of reflecting the light LG1, may be used.

In such a case, in a location where the air curtain apparatus **1** of the present embodiment is installed, it is also possible to further visually and easily confirm whether or not the helical air current SA1 blown out from the air outlet port **14** of the blower **11** reaches straight the air inlet port **23** of the blower **21** (whether or not it arrives) by adjusting the relative position of the air inlet unit **4** with the respect to the air outlet unit **3**, while irradiating the light receiving unit **62** of the blower **21a** with the light applied by the light emitting unit **61** included in the blower **11**. Therefore, it is further possible to ensure that the blower **11** is reliably associated with the blower **21** on a one-to-one basis.

Preferably, when viewed from the blower **11** toward the blower **21**, a rotation direction of the helical air current SA1, which is blown out by the blower **11** from the air outlet port **14** included in the blower **11** toward the air inlet port **23** included in the blower **21**, is a clockwise or anti-clockwise rotation direction, and is the same rotation direction among the plurality of blowers **11**. In other words, the plurality of blowers (circulators) **11** each blowing out the helical air current SA1 is aligned (arrayed) lengthwise, more specifically, in the up-down direction, the helical air current SA1 having the helical shape (spiral shape) that rotates in the same direction of the clockwise or anti-clockwise rotation direction.

In a case where the two (two units of) blowers **11** adjacent to each other in the up-down direction each blow out the helical air current SA1 having the helical shape (spiral shape) rotating in the direction that is the clockwise or anti-clockwise direction and the same as each other, the two (two units of) blowers **11** are able to strengthen an amount of air to be blown out (wind force), stabilize the wind force, and easily maintain the wind force, as compared with a case where the two (two units of) blowers **11** each blows out the helical air current SA1 having the helical shape that rotates in a reverse direction to each other.

Preferably, each of the plurality of blowers **11** further includes a grille **63** that has a plurality of holes **63a** formed therein, the plurality of holes **63a** being provided at the air outlet port **14** and each having the helical shape that swirls clockwise or anti-clockwise when viewed from the axial

direction of the cylinder part **32**. Each of the plurality of holes **63a** penetrates the grille **63** in the axial direction of the cylinder part **32**.

In a case where the plurality of holes **63a** formed in the grille **63** each has the helical shape that swirls clockwise or anti-clockwise, it is possible to blow out the helical air current SA1 having the helical shape (spiral shape) more easily than a case where the plurality of holes **63a** formed in the grille **63** does not have the helical shape that swirls clockwise or anti-clockwise. It is to be noted that when viewed from the blower **21** toward the blower **11**, the rotation direction of the helical shape of the holes **63a** formed in the grille **63**, the rotation direction of the helical air current SA1 blown out by the blower **11**, and the rotation direction of the fan **33** are all the same direction of rotation.

Preferably, the air curtain forming unit **2** may have a connection unit **64** (see FIG. 1) that connects in an air-tight manner an end of the air inlet unit **4** opposite to side facing the air outlet unit **3** with an end of the air outlet unit **3** opposite to side facing the air outlet unit **4**. That is to say, the air curtain forming unit **2** has the connection unit **64** that connects the plurality of air outlet ports **24** each included in each of the plurality of blowers **21** and the plurality of air inlet ports **13** each included in each of the plurality of blowers **11** in an integrated manner or on a one-to-one basis. A connection unit made of a metal material, a resin material such as plastics, or an elastic material such as rubber, or the like, may be used as the connection unit **64**.

In such a case, when foreign matters such as droplets enter the air curtain AC1, it is possible to prevent or suppress entry into any space other than the air curtain AC1, including entry of the entering foreign matters into any of the two subspaces SP1 and SP2 located on both sides with the air curtain AC1 as the center.

First Modification Example of Air Curtain Apparatus

Next, a description is given of a first modification example of the air curtain apparatus of the embodiment. While the air curtain apparatus **1** of the embodiment includes the one (one unit) of the air curtain forming unit **2**, an air curtain apparatus **1** of this first modification example includes two (two units) of air curtain forming units **2**. Those two (two units) of air curtain forming units **2** are connected to each other in an air-tight manner.

FIG. 6 is a top view schematically illustrating a configuration of the air curtain apparatus of the first modification example of the embodiment.

As illustrated in FIG. 6, unlike the air curtain apparatus **1** of the embodiment, the air curtain apparatus **1** of this first modification example includes the two (two units) of air curtain forming units **2**. Similarly to the air curtain forming unit **2** included in the air curtain apparatus **1** of the embodiment, each of the two (two units) of air curtain forming units **2** includes an air outlet unit **3** and an air inlet unit **4**. The air outlet unit **3** has a plurality of blowers **11** and the air inlet unit **4** includes a plurality of blowers **21**. More specifically, each of the two (two units) of air curtain forming unit **2** includes the plurality of blowers **11** and the plurality of blowers **21**. Note that the plurality of blowers **11** and the plurality of blowers **21** may be made similar to the plurality of blowers **11** and the plurality of blowers **21** in the embodiment.

In the first modification example, the plurality of blowers **21** held by an air curtain forming unit **2a**, which is any of the two units of air curtain forming units **2**, is adjacent to the

plurality of blowers **11** held by an air curtain forming unit **2b**, in a plan view. The air curtain forming unit **2b** is different from the air curtain forming unit **2a** of the two units of air curtain forming units **2**. Note that the air curtain forming unit **2a** forms an air curtain **AC11** as the air curtain **AC1**, and that the air curtain forming unit **2b** forms an air curtain **AC12** as the air curtain **AC1**.

In a plan view, a direction from the plurality of blowers **11** held by the air curtain forming unit **2b** towards the plurality of blowers **21** held by the air curtain forming unit **2b** differs from a direction from the plurality of blowers **11** held by the air curtain forming unit **2a** toward the plurality of blowers **21** held by the air curtain forming unit **2a**. In other words, in a pair of the blower **11** and the blower **21**, a direction in which the helical air current **SA1** (see FIG. 1) is blown out from the air outlet port **14** included in the blower **11** is a direction that mutually differs between the two units of air curtain forming units **2**.

The air curtain forming unit **2a** has a connection unit **65** that connects in an air-tight manner a plurality of air outlet ports **24** each included in each of the plurality of blowers **21** held by the air curtain forming unit **2a** with a plurality of air inlet ports **13** each included in each of the plurality of blowers **11** held by the air curtain forming unit **2b**, in an integrated manner or on a one-to-one basis.

That is to say, in the air curtain apparatus **1** of this first modification example, the air curtain forming units **2** of the pair, more specifically, the two (two units) of air curtain forming units **2**, which are adjacent to each other, are connected by the connection unit **65**. It suffices that the connection unit **65** is able to connect the plurality of air outlet ports **24** each included in each of the plurality of blowers **21** held by the air curtain forming unit **2a** with the plurality of air inlet ports **13** each included in each of the plurality of blowers **11** held by the air curtain forming unit **2b**, in an air-tight manner. Therefore, a connection unit made of a metal material, a resin material such as plastics, or an elastic material such as rubber, or the like, may be used as the connection unit **65**.

According to this first modification example, in addition to achievement of the effects similar to the embodiment, it is further possible to freely extend the air curtain and to freely bend the air curtain in a plan view. Consequently, even in a case where a layout is limited such as a case where an air curtain is formed along a curved aisle in a plan view, for example, it is possible to install the air curtain apparatus easily. Moreover, when foreign matters such as droplets enter the air curtain **AC11** formed by the air curtain forming unit **2a**, it is possible to prevent or suppress entry of the entering foreign matters into any of two subspaces that are located on both sides with the air curtain **AC12** as the center, the air curtain **12** being formed by the air curtain forming unit **2b**.

Second Modification Example of Air Curtain Apparatus

Next, a description is given of a second modification example of the air curtain apparatus of the embodiment. While the air curtain apparatus **1** of the embodiment includes the one (one unit) of air curtain forming unit **2**, an air curtain apparatus **1** of this second modification example includes **N** air curtain forming units (**N** unit s, **N** being an integer of 3 or larger). Those **N** (**N** unit s) of air curtain forming units **2** are arrayed along a circular route **CR1**. The two (two units) of air curtain forming units **2**, which are

adjacent to each other along the circular route **CR1**, are connected in an air-tight manner.

FIG. 7 is a top view schematically illustrating the air curtain apparatus of the second modification example of the embodiment. Note that FIG. 6 illustrates a configuration similar to that illustrated in an enlarged view of the area **AR1** surrounded by a two-dot chain line in FIG. 7.

As illustrated in FIG. 7, unlike the air curtain apparatus **1** of the embodiment, the air curtain apparatus **1** of this second modification example includes **N** (**N** units, **N** being an integer of 3 or larger) of air curtain forming units **2**. The **N** air curtain forming units **2** are arrayed along the circular route **R1** around a central axis **AX1**, which is along the up-down direction, and each form the air curtain **AC1**. FIG. 7 illustrates a case where **N=8**. Similarly to the air curtain forming unit **2** included in the air curtain apparatus **1** of the embodiment, each of the **N** (**N** units) of air curtain forming units **2** includes an air outlet unit **3** and an air inlet unit **4**. The air outlet unit **3** has a plurality of blowers **11** and the air inlet unit **4** includes a plurality of blowers **21**. More specifically, each of the **N** (**N** units) of air curtain forming units **2** has the plurality of blowers **11** and the plurality of blowers **21**. Note that the plurality of blowers **11** and the plurality of blowers **21** may be made similar to the plurality of blowers **11** and the plurality of blowers **21** in the embodiment.

In this second modification example, for each of the **N** (**N** units) of air curtain forming units **2**, in a pair of an air curtain forming unit **2c** which is an air curtain forming unit, and an air curtain forming unit **2d**, which is located on first side and is the air curtain forming unit **2** adjacent to the air curtain forming unit **2c**, a plurality of blowers **21** held by the air curtain forming unit **2c** is adjacent to a plurality of blowers **11** held by the air curtain forming unit **2d** in a plan view. The first side is, in a plan view, side of an anti-clockwise direction or that of a clockwise direction of the air curtain forming unit **2c** of the **N** air curtain forming units **2** along the circular route **CR1**. Note that while any of the **N** (**N** units) of air curtain forming units **2** forms the air curtain **AC1**, an annular air curtain **AC2** having an annular shape in a plan view shall be formed by the plurality of air curtains **A1** each formed by each of the **N** (**N** units) of the air curtain forming units **2**.

The air curtain forming unit **2c** has a connection unit **66** that connects in an air-tight manner a plurality of air outlet ports **24** (see FIG. 6) each included in each of the plurality of blowers **21** held by the air curtain forming unit **2c** with a plurality of air inlet ports **13** (See FIG. 6) each included in each of the plurality of blowers **11** held by the air curtain forming unit **2d**, in an integrated manner or on a one-to-one basis.

That is to say, similarly to the air curtain apparatus **1** of the first modification example of the embodiment, in the air curtain apparatus **1** of this second modification example, a pair of air curtain forming units **2** which are adjacent to each other, more specifically, the two (two units) of air curtain forming units **2**, which are adjacent to each other, are connected by the connection unit **66**. It suffices that similarly to the connection unit **65** in the first modification example of the embodiment, the connection unit **66** is able to connect the plurality of air outlet ports **24** (See FIG. 6) each included in each of the plurality of blowers **21** held by the air curtain forming unit **2c** with the plurality of air inlet ports **13** (See FIG. 6) each included in each of the plurality of blowers **11** held by the air curtain forming unit **2d**, in an air-tight manner. Therefore, similarly to the connection unit **65** in the first modification example of the embodiment, a connection unit made of a metal material, a resin material such as

plastics, or an elastic material such as rubber or the like may be used as the connection unit **66**.

According to this second modification example, the N (N units) of air curtain forming units **2** are arrayed along the circular route CR1 and the two (two units) of air curtain forming units **2**, which are adjacent to each other along the circular route CR1, are connected in an air tight manner. Thereby, in addition to achievement of the effects similar to the embodiment, it is further possible to easily form a space surrounded by the annular air curtain AC2 having an annular shape in a plan view. In addition, when foreign matters such as droplets enter the annular air curtain AC2, it is possible to prevent or suppress entry of the entering foreign matters into the space surrounded by the annular air curtain AC2 and into a space on circumferential side of the annular air curtain AC2 with the central axis AX1 as the center.

Third Modification Example of Air Curtain Apparatus

Next, a description is given of a third modification example of the air curtain apparatus of the embodiment. FIG. **8** is a cross-sectional diagram schematically illustrating a configuration of an air curtain apparatus of the third modification example of the embodiment. Note that in FIG. **8**, a part of the air curtain AC1 is depicted as an air curtain AC10.

As illustrated in FIG. **8**, in the air curtain apparatus **1** of this third modification example, each of a plurality of blowers **11** includes a spraying unit (sprayer) **71** that sprays an antiseptic solution **71a** inside a cylinder part **32**. More specifically, in the air curtain apparatus of this third modification example, each of a plurality of blowers **11** includes means (function) of spraying the antiseptic solution **71a** that inactivates or disinfects viruses or bacteria, in addition to a fan **33** that blows out air. An antiseptic solution containing ethyl alcohol (ethanol) or chorine, for example, may be used as the antiseptic solution **71a**.

Consequently, in addition to obtaining the similar effects to the embodiment, the helical air current SA1 blown out from each of the plurality of blowers **11** contains the antiseptic solution SA1 and thus viruses or bacteria are easily inactivated or disinfecting by the air curtain AC1 itself. Therefore, the air curtain AC1 itself is able to remove viruses or bacteria. As a result, in a case where the two users **52** (see FIG. **3**) face each other or where the user **52** (See FIG. **3**) and the employee **53** (See FIG. **3**) face each other, with the air curtain AC in between, it is further possible to ensure that an infectious disease is reliably prevented from being transmitted between the two users **52** or between the user **52** and the employee **53**.

Fourth Modification Example of Air Curtain Apparatus

Next, a description of a fourth modification example of the air curtain apparatus of the embodiment is given. FIG. **9** is a cross-sectional diagram schematically illustrating a configuration of an air curtain apparatus of the fourth modification example of the embodiment. Note that in FIG. **9**, a part of the air curtain AC1 is depicted as the air curtain AC10.

As illustrated in FIG. **9**, in the air curtain apparatus **1** of this fourth modification example, in a pair of a blower **11** and a blower **21**, an inner diameter ID2 of an air inlet port **23** included in the blower **21** is larger than an inner diameter ID1 of an air outlet port **14** included in the blower **11**. In

addition, a cylinder part **42** is able to have a shape with an inner diameter of the cylinder part **42** gradually increasing toward the air inlet port **23**.

Consequently, in addition to achievement of the effects similar to the embodiment, further, an inner diameter ID2, which is an opening size of the air inlet port **23** included in the blower **21**, is made wider than the inner diameter ID1, which is an opening size of the air outlet port **14** included in the blower **11**. Therefore, the air inlet unit **4** sucks in air easily from the air inlet port **23** included in the blower **21** held by the air inlet unit **4**, and it is possible to prevent or suppress air, which is blown out from the air outlet port **14** included in the blower **11** held by the air outlet unit **3**, from being released without being sucked into the blower **21** held by the air inlet unit **4**.

Fifth Modification Example of Air Curtain Apparatus

Next, a description is given of a fifth modification example of the air curtain apparatus of the embodiment. FIG. **10** is a cross-sectional diagram schematically illustrating a configuration of an air curtain apparatus of the fifth modification example of the embodiment. Note that in FIG. **10** a part of the air curtain AC1 is depicted as the air curtain AC10.

As illustrated in FIG. **10**, in the example of the air curtain apparatus **1** of this fifth modification example, each of a plurality of blowers **11** includes an injection unit (injector) **72** that injects a colored gas GS1 into a cylinder part **32**. More specifically, in the example of the air curtain apparatus **1** of this fifth modification example, the air curtain AC1 is colored or the air curtain AC1 contains smoke according to an application or a design of a space. This alerts users that the air curtain apparatus is installed, for example, and promotes awareness about prevention of the users or the like. Therefore, it possible to enhance the effect of preventing infection.

Coloring designed for strong alert includes yellow and black coloring like so-called "Tora Tape (safety stripe tape)" such as positive alert, no entry, or off-limits due to construction, and red coloring such as a pylon for alert on the road. In addition, coloring designed for further strong alert includes coloring by a relatively strong color such as a smoke marker. In addition, coloring includes coloring designed to make it objectively easy to understand that a space is separated by an air curtain. In addition, in a case where an air curtain is formed that allows for light communications, not strong off-limits, coloring includes coloring designed to encourage use of the air curtain with a little attention. In such a case, because it is loose alert, coloring is not necessary to be such a strong color, and coloring with a slightly weak color is sufficient.

In various spaces such as a sales floor of a store or the like, although a partition separating a space, or the like, may be installed, there are some cases in which it is desired to color the partition or the like according to the atmosphere of the sales floor, or the like. Furthermore, in some cases, a transparent but lightly colored partition may be preferred over a transparent and uncolored partition, from the perspective that it is better not to see faces clearly when users and employees face each other, like a cash desk (accounting).

According to the example of the air curtain apparatus **1** of this fifth modification example, in addition to achievement of the effect similar to the embodiment, by coloring the air curtain AC1 according to the application or the design of the

space or by the air curtain AC containing smoke, it is further possible to meet the demand to color the partition or the like according to the atmosphere of the sales floor or the like or the demand that the faces are not seen too clearly in a case where the users and the employees face each other.

Alternatively, as illustrated in FIG. 10, in another example of the air curtain apparatus 1 of this fifth modification example, each of a plurality of blowers 11 includes an injection unit (injector) 73 that injects a gas GS2 containing a smell component into the cylinder part 32. More specifically, in the other example of the air curtain apparatus 1 of this fifth modification example, the air curtain contains a smell according to the application or the atmosphere of the space. This alerts users that the air curtain apparatus is installed, for example, and promotes awareness about prevention of the users or the like. Therefore, it is possible to enhance the effect of preventing infection.

Examples of the smell includes a smell fitted for a theme of a café or a restaurant or the like, or a smell of steak or popcorn, a smell fitted for an atmosphere of a theme park, or a smell fitted for flowers of the four seasons. Alternatively, examples include a smell of a refreshing atmosphere that matches business negotiations, or a smell of a relaxing atmosphere such as a massage parlor. Alternatively, examples include a smell having the effect of deodorizing near a smoking room or a toilet, or a smell reminiscent of the natural environment.

In various spaces such as a sales floor of a store or the like, there are some cases where it may be desirable to contain various types of smells such as a smell of coffee according to the atmosphere or theme of the sales floor. According to the other example of the air curtain apparatus 1 of this fifth modification example, in addition to achievement of the effect similar to the embodiment, by the air curtain AC1 containing a smell according to the application or atmosphere of the space, it is further possible to meet a demand to include various types of smells according to the atmosphere of theme of the sales floor.

It is to be noted that any one type or a plurality of types of the air curtain apparatus of the embodiment and the first to fifth modification examples of the embodiment may be combined, where appropriate.

Sixth Modification Example of Air Curtain Apparatus

Next, a description is given of a sixth modification example of the air curtain apparatus of the embodiment. FIG. 11 is an explanatory diagram schematically illustrating a configuration of a blower 11 according to an air curtain apparatus of the sixth modification example of the embodiment. FIG. 11A is a perspective view and FIG. 11B is a lateral view. In the air curtain apparatus of the sixth modification example, the blower 11 includes an identification apparatus 80 that makes it possible to visually identify a traveling direction of the helical air current SA1 (see FIG. 1) blown out from an air outlet port 14 included in the blower 11.

The identification apparatus 80 includes a stretching part 81 and a placement part 82. The stretching part 81 includes a long steel strip-shaped member 83 and a storing body 84 that stores the strip-shaped member 83 in its wound state.

In the strip-shaped member 83, warp is formed from a central portion in a width direction toward both side parts. In a case where the strip-shaped member 83 is stretched

straight, it is not broken easily due to the warp in the central part in the width direction, thus being maintained in a straightened state.

The storing body 84 is connected to a base end portion of the strip-shaped member 83, and includes a rotating shaft 88 capable of winding up the strip-shaped member 83; and a storing case rotatably supporting the rotating shaft 88 and storing the strip-shaped member 83 wound up by the rotating shaft 88. The storing body 84 also includes a drawer port 86 for drawing the strip-shaped member 83. The storing body 84 also includes a stopper function of maintaining the strip-shaped member 83 (not illustrated) in a drawn state and releasing the maintenance. When the stopper function is released, the rotating shaft 88 rotates and the strip-shaped member 83 is wound around the rotating shaft 88. A tip of the strip-shaped member 83 wound up by the rotating shaft 88 is positioned outside of the drawer port 86.

When the strip-shaped member 83 is wound up by the rotating shaft 88, the warp in the central portion becomes small and planar due to elastic deformation. Thus, the strip-shaped member 83 is wound up easily by the rotating shaft 88.

The drawer port 86 is formed in a rectangle that is slightly larger than a width of the strip-shaped member 83.

The placement part 82 includes an approximately cuboid member. With a lower surface being an arc-shaped surface recessed in a half-pipe shape, the placement part 82 is formed so that it may be placed on a side face of the cylinder part 32. In addition, a recess 87 is formed in a middle part of a top face of the placement part 82. The recess 87 is formed slightly larger than the width of the strip-shaped member 83, and extends parallel to an imaginary central axis of the arc-like surface on the lower surface. The recess 87 also penetrates an upper part of a front surface and that of a back surface of the approximately cuboid.

The placement part 82 is fixed to an upper part of a side edge portion of the air outlet port 14 on the side face of the cylinder part 32. The storing body 84 is fixed to the side face of the cylinder part 32, with a predetermined space with respect to the placement part 82. Here, in a front view of the blower 11 from side of the air outlet port 14, a bottom face of the recess 87 approximately matches that of the drawer port 86. The strip-shaped member 83 drawn from the storing body 84 may be placed inside the recess 87 of the placement part 82. Transverse movement of the strip-shaped member 83 placed in the placement part 82 is restricted by wall surfaces of both side parts of the recess 87. The tip of the strip-shaped member 83 which further extends from the placement part 82 extends approximately parallel to the central axis 31 (See FIG. 2). Here, the direction of the central axis 31 (See FIG. 31) is approximately parallel to the traveling direction of the helical air current blown out from the blower 11. Therefore, the direction in which the tip of the strip-shaped member 83 further extends from the placement part 82 is approximately parallel to the traveling direction of the helical air current.

When a second blower 11 is positioned with respect to a second blower 11, the strip-shaped member 83 is drawn from the storing body 84 and placed inside the recess 87 of the placement part 82. Further, by being drawn, the strip-shaped member 83 is caused to extend from the recess 87 of the placement part 82. This makes it possible to figure out the traveling direction of the helical air current blown out from the air outlet port 14 that is included in the blower 11, by visually recognizing the strip-shaped member 83 extending from the placement part 82. Consequently, it is possible to make the strip-shaped member 83 a mark in determining

a location of the blower **21** which corresponds to the blower **11**. After the location of the blower **21** is determined, it becomes possible to store the strip-shaped member **83** compactly, by rotating the rotating shaft **88** to cause the rotating shaft **88** to wind the strip-shaped member **83**.

FIG. **12** is an explanatory diagram illustrating another configuration **1** of the identification apparatus **80** in the sixth modification example. FIG. **12A** is a perspective view and FIG. **12B** is a lateral view.

The identification apparatus **80** in the other configuration **1** includes the placement part **82** and a scope unit **90**. Note that in the other configuration **1** illustrated in FIG. **12**, the same members or the same functions as those of the air curtain apparatus of the sixth modification example may be designated by the same reference numerals, and a detailed description thereof is omitted.

The scope unit **90** includes a scope **91** and a support **92** that supports the scope **91**. The scope **91** includes a cylindrical member. The support **92** forms a T-shape including a columnar bar-like horizontal shaft and a vertical shaft extending from the center of this horizontal shaft.

On the bottom face of the recess **87** is formed a T-shaped groove part **87a** capable of storing the support **92**. Both ends of a horizontal axis of the groove part **87a** are formed as a hole part that is cut out more deeply than the wall surfaces of the recess **87**. A vertical axis of the groove part **87a** extends from a middle portion of the horizontal axis of the groove part **87a** to side of the air inlet port **13**.

Both ends of the horizontal shaft of the support **92** are rotatably supported by the hole parts (not illustrated) formed at the both ends of the horizontal axis of the groove part **87a**. This makes it possible for the vertical shaft of the support **92** to swing in a direction along the imaginary central axis of the cylinder part **32**. In addition, the placement part **82** is provided with a stopper mechanism that restricts swinging of the vertical shaft of the support **92**. In a case where the vertical shaft of the support **92** is turned to the side of the air outlet port **14** and the vertical shaft of the support **92** is perpendicular to the imaginary central axis of the cylinder part **32**, this stopper mechanism restricts further turning.

The scope **91** is fixed to a tip of the vertical shaft of the support **92**.

When the second blower **11** is positioned with respect to the first blower **11**, the vertical shaft of the support **92** is turned to the side of the air outlet port **14** till the movement is restricted. At this time, the imaginary central axis of the scope **91** is approximately parallel to the imaginary central axis of the cylinder part **32**. Therefore, it becomes possible to figure out a direction to an object visually recognized via the scope **91** as the traveling direction of the helical air current blown out from the air outlet port **14** included in the blower **11**. This allows for positioning of the air curtain apparatus by adjusting the location of the first blower **11** or the second blower **21**, so that the upper part of the blower **21** may be visually recognized through the scope **91**.

In a case where the scope **91** is not used, it is possible to turn the support **92** to side of the cylinder part **32** and keep it tilted down. At this time, the support **92** is stored in the groove part **87a**.

Note that the scope **91** may be supported rotatably in a range of 90 degrees to the tip of the vertical shaft of the support **92**. In a case where the scope **91** is not used, this makes it possible to turn the scope **91** by 90 degrees and tilt down the vertical shaft of the support **92** with the imaginary central axis of the scope **91** being approximately parallel to the horizontal shaft of the support **92**. As a result, by rotating

the scope **91** by 90 degrees, it is possible to tilt even a long scope **91**, when not in use, to the side of the cylinder part **32** together with the support **92**.

FIG. **13** is a lateral view illustrating another configuration **2** of the identification apparatus **80** in the sixth modification example. FIG. **13A** illustrates a state in use and FIG. **13B** illustrates a state prior to use.

The identification apparatus **80** in the other configuration **2** includes the placement part **82** and a long member **93**. Note that in the other configuration **2** illustrated in FIG. **13**, the same members or the same functions as those of the air curtain apparatus of the sixth modification example as illustrated in FIG. **11** may be designated by the same reference numerals, and a detailed description thereof is omitted.

The long member **93** includes a plurality of short members **94** and a hinge **95** that connects the adjacent short members **94** to each other. The plurality of short members **94** is formed like a plate and all is of a same type. The hinge **95** connects ends of the two short members **94** in a longitudinal direction. When the two short members **94** are unfolded, end faces of the two short members **94** in the longitudinal direction come into contact with each other, making a long strip shape. When the two short members **94** are folded, a lower surface of the other short member **94** is in contact with an upper surface of the one short member **94**, thus resulting in a state in which the short member **94** is stacked on the short member **94**.

The long member **93** is switchable from a form as illustrated in FIG. **13A** in which the plurality of short members **94** is turned to make a long strip shape to a form as illustrated in FIG. **13B** in which the plurality of short members **94** is turned to alternately stack the second lowest short member **94** on the lowest short member **94** to make a cuboid.

A locking mechanism (not illustrated) is provided at a connection region in the adjacent short members **94**, **94**. When the adjacent members **94**, **94** are unfolded to form a single strip-shaped member, this locking mechanism makes it possible to maintain that state. In addition, in a front view of the blower **11** from the side of the air outlet port **14**, a pedestal is placed between the cylinder part **32** and the lowest short member **94** so that a position of the bottom face of the recess **87** approximately matches that of the lower surface of the lowest short member **94**.

As illustrated in FIG. **13A**, the long member **93** is installed on the cylinder part **32** via the pedestal, with a predetermined space with respect to the placement part **82**. In a case where the long member **93** is made to have a single long strip-shaped form as illustrated in FIG. **13A**, a portion of the long member **93** is placed on the bottom face of the recess **87** in the placement part **82**. As a result, because the short member **94** at the tip and the short member **94** at the base end portion are on the same level, the tip of the long member **93** extending from the placement part **82** extends approximately parallel to the central axis **31** (see FIG. **2**).

Then, by visually recognizing the long member **93** extending from the placement part **83** in determining the location of the blower **21** corresponding to the blower **21**, it becomes possible to figure out the traveling direction of the helical air current blown out from the air outlet port **14** included in the blower **11**. As such, it becomes possible to make the strip-shaped member **83** a mark in determining the location of the blower **21** corresponding to the blower **11**. After the location of the blower **21** is determined, it becomes

possible to keep the long member **93** in a compact state, by folding the long member **93** and stacking the short member **94**.

FIG. **14** is a lateral view illustrating another configuration **3** of the identification apparatus **80** in the sixth modification example. FIG. **14A** illustrates a state in use and FIG. **14B** illustrates a state prior to use.

The identification apparatus **80** in the other configuration **3** includes the placement part **82** and a rod member **96**. Note that in the other configuration **2** illustrated in FIG. **14**, the same members or the same functions as those of the air curtain apparatus in the other configuration **2** of the sixth modification example as illustrated in FIG. **13** may be designated by the same reference numerals, and a detailed description thereof is omitted.

In the identification apparatus **80** in the other configuration **3**, the long member **93** in the identification apparatus **80** in the other configuration **2** is replaced with the rod member **96**.

The rod member **96** is such configured that a plurality of cylinder members is concentrically stored within a cylinder member of the largest diameter. The rod member **96** is a stretchable member that may be stretched longitudinally to a plurality of stages, by pulling the plurality of cylinder members from the inside of the cylinder member of the largest diameter, and that, to the contrary, may be stored inside the cylinder member of the largest diameter by pushing the other cylinder members into the cylinder member of the largest diameter.

As illustrated in FIG. **14A**, the rod member **96** is installed on the cylinder part **32** via the pedestal, with a predetermined space with respect to the placement part **82**. In a case where the rod member **96** is stretched so as to be a bar-like member, as illustrated in FIG. **14A**, a portion of the rod member **96** is placed on the bottom face of the recess **87** in the placement part **82**.

Here, the recess **87** in the placement part **82** is formed to have a width slightly larger than a diameter of the cylinder member placed on the recess **87** in the rod member **96**. In addition, a position of the bottom face of the recess **87** is set to be slightly higher than the lowest position of the cylinder member of the largest diameter in the rod member **96** placed in the cylinder part **32**. Specifically, the position of the bottom surface of the recess **87** is set to be higher than the lowest position of the cylinder member of the maximum diameter, only by a difference between a radius of the cylinder member of the largest diameter in the rod member **96** and that of the cylinder member placed on the recess **87** in the rod member **96**. As a result, the tip of the rod member **96** extending from the placement part **82** extends approximately parallel to the central axis **31** (See FIG. **2**).

Then, by visually recognizing the rod member **96** extending from the placement part **82** in determining the location of the blower **21** corresponding to the blower **11**, it becomes possible to figure out the traveling direction of the helical air current blow out from the air outlet port **14** included in the blower **11**. As such, it becomes possible to make the rod member **96** a mark in determining the location of the blower **21** corresponding to the blower **11**. After the location of the blower **21** is determined, it becomes possible to keep the rod member **96** in a compact state, by pushing the tip of the rod member **96** into side of the cylinder part of the largest diameter.

FIG. **15** is a diagram illustrating another configuration **4** of the identification apparatus **80** in the sixth modification example. FIG. **15A** is a lateral view illustrating a state prior

to use, FIG. **15B** is a lateral view illustrating a state in use, and FIG. **15C** is a top view of FIG. **15B**.

The identification apparatus **80** in the other configuration **4** includes the placement part **82** and a blow-back member **100**. Note that in the other configuration **2** illustrated in FIG. **13**, the same members or the same functions as those of the air curtain apparatus of the sixth modification example may be designated by the same reference numerals, and a detailed description thereof is omitted.

The blow-back member **100** includes a belt-like bag body **101** having an open base end portion and a closed tip; a ringed thread-like member **102** attached to the base end portion of the bag body **101** and capable of being hung on the placement part **82**; and a linear spring member **103** attached to a middle portion of the bag body **101** in the width direction and extending along the longitudinal direction of the bag body. In the blow-back member **100**, in a normal state, the spring member **103** is in a curled state like a spiral, and thus, the bag body **101** is maintained in the curled state like a spiral, as illustrated in FIG. **15A**.

By hanging the thread-like member **102** on the placement part **82** while in use, the identification apparatus **80** of the other configuration **4** positions the blow-back member **100** in front of the blower **11** and causes the base end portion of the back body **101** to face the air outlet port **14**.

Then, thereafter, turning the power on the blower **11** causes the helical air current to be blown out from the air outlet port **14**. When the helical air current is blown out from the air outlet port **14**, a portion of that air current flows from the base end portion of the bag body **101**, thus maintaining the bag body **101** in a linearly extended state, as illustrated in FIG. **15B**. A direction in which this bag body **101** is extended makes it possible to figure out the traveling direction of the helical air current blown out from the air outlet port **14** included in the blower **11**. As such, it becomes possible to make the bag body **101** in the blow-back member **100** a mark in determining the location of the blower **21** corresponding to the blower **11**. By stopping the blower **11** after the location of the blower **21** is determined, the bag body **101** returns to the curled state by deforming the spring member **103** in the helical shape of the original. Note that the bag body **101** in the curled state may be stored in the recess **87**.

Note that the identification apparatuses **80** illustrated in FIG. **11** to FIG. **15** may be combined where appropriate. FIG. **16** is a perspective view illustrating an example of a configuration in which the identification apparatus **80** of FIG. **11** and the identification apparatus **80** of FIG. **12** are combined. When the location of the blower **21** corresponding to the blower **11** is determined, first of all, as illustrated in FIG. **12**, the scope unit **90** is raised to locate the blower **21** at a position where the blower **21** is visible through the scope unit **90**. Then, scope unit **90** is tilted down to install the stretching part **81** in the cylinder part **32**. As illustrated in FIG. **16**, the strip-shaped member **83** is extended from the stretching part **81** to be installed in the placement part **82**. Then, it is possible to determine the position of the blower **21** by adjusting the position of the blower **21** while looking at the strip-shaped member **83**.

In addition, the identification apparatus **80** may be detachable with respect to the cylinder part **32**. As a result, after alignment of the blower **21** of the air inlet unit **4** corresponding to one blower **11** in the plurality of blowers **11** of the air outlet unit **3** ends, it becomes possible to remove the identification apparatus **80**, to attach the identification apparatus **80** to the next blower **11**, and to align the blower **21** corresponding to the next blower **11**.

In addition, the identification apparatus **80** may be installed individually to each of the plurality of blowers **11** of the air outlet unit **3**. FIG. **17** is a perspective view illustrating an example of a configuration in which the identification apparatus **80** illustrated in FIG. **11** is attached to each of the plurality of blowers **11** of the air outlet unit **3**. In the example illustrated in FIG. **17**, a placement part **97** is attached to each of the plurality of blowers **21** held by the air inlet unit **4**. The placement part **97** of the blower **21** is located on an upper part of a side edge portion of the air inlet port **23** in the cylinder part **42**.

In alignment of the blower **11** and the blower **21**, first, each of the strip-shaped members **83** is drawn from the stretching part **81** installed in each of the plurality of blowers **11** of the air inlet unit **3** and placed on the placement part **97**, and the tip thereof is caused to extend from the blower **11**. Then, the plurality of blowers **21** held by the air inlet unit **4** has is located to face the plurality of blowers **11** of the air outlet unit **3** at predetermined intervals. Then, the blower **11** is visually recognized from the side of the air outlet port **24** of the blower **21**. A direction of the blower **21** is adjusted so that the tip of the strip-shaped member **83** is located in the placement part **97** of the blower **21**. By making such an adjustment on the plurality of blowers **11** of the air outlet unit **3**, it is possible to determine the position of the blower **21** with respect to the blower **11**.

As described above, according to the sixth modification example, the direction in which the strip-shaped member **83**, the long member **93**, the rod member **96**, or the blow-back member **100** extends serves as the mark that indicates the direction in which the helical air current flows from the blower **11**. Therefore, by referring to this mark in locating the blower **21**, it is possible to locate the blower **21** along the direction of the helical air current that flows from the blower **11**. Moreover, by locating the blower **21** in the range visible through the scope unit **90**, it is possible to locate the blower **21** along the direction of the helical air current that flows from the blower **11**. As such, according to the sixth modification example, it is possible to visually determine the direction of the helical air current that blows from the blower **11**, which thus makes it possible to easily install the air curtain apparatus.

Note that the light emitting unit **61** and the light receiving unit **62** may be provided in the blower **11** and the blower **21** of the sixth modification example. Furthermore, an output apparatus may be provided that outputs sound or an image when the light receiving unit **62** receives light from the light emitting unit **61**. This makes it possible to inform a worker that positioning is complete, by the output apparatus outputting the sound or the image when the worker is performing a positioning work of the blower **21** with reference to the mark of the blower **11**. In this case, the light from the light emitting unit **61** may be invisible light.

In addition, when the worker performs the positioning work of the blower **21** with reference to the mark of the blower **11**, a pressure sensor is temporarily attached to the air inlet port **23** of the blower **21a** so that a measurement result of this pressure sensor may be confirmed by a display apparatus. Then, the worker may adjust the position of the blower **11** and the position of the blower **21** so as to have the maximum wind pressure.

Seventh Modification Example of Air Curtain Apparatus

Next, a description is given of a seventh modification example of the air curtain apparatus of the embodiment.

FIG. **18** is an explanatory diagram schematically illustrating a skeleton framework of the seventh modification example. An air curtain apparatus of the seventh modification example includes a plurality of blowers **11**, a plurality of blowers **21** corresponding to the plurality of blowers **11**, a controller **200** that drives and controls the blowers **11** and the blowers **21**, and a sensing apparatus **300** that senses a person.

The plurality of blowers **11** is installed on a ceiling and the plurality of blowers **21** is installed on a floor. The plurality of blowers **11** blows out helical air currents vertically downward toward the floor. Located vertically below the plurality of blowers **11**, the plurality of blowers **21** sucks in the helical air currents from the plurality of blowers **11** and blows out the helical air currents vertically downward. As a result, it is possible to form an air screen in the up-down direction by the plurality of blowers **11** and blowers **21**.

The controller **200** includes a control unit **201** that controls an air curtain apparatus and a storage unit **202** that stores various types of programs. In the storage unit **202** are stored a program that determines positional information of a person on the basis of sensing information from the sensing apparatus **300**, a program that controls on or off of the blowers **11** and the blowers **21**, an increase or decrease in an air quantity, or the like on the basis of the positional information of the person, or the like. The control unit **201** is able to individually control the plurality of blowers **11** and blowers **21**. Consequently, the control unit **201** is able to perform control, such as increasing or decreasing a breadth of the air screen.

The control unit **201** is not specifically limited as long as the control unit **201** is able to individually control the plurality of blowers **11** and blowers **21**. The control unit **201** may be a control unit having one or more electronic circuits including a microcomputer or an integrated circuit (Integrated Circuit, IC) which is configured by using a CPU (Central Processing Unit), a RAM (Random Access Memory), and a ROM (Read Only Memory) or the like.

The storage unit **202** is an apparatus in which data or a file is stored, and has a data storage unit implemented by using one or more storage means exemplified by a hard disk, a semiconductor memory, a storage medium, and a memory card, or the like.

The sensing apparatus **300** senses a position of a person and transmits information thereof to the controller **200**. As the sensing apparatus **300** may be applied an imaging apparatus such as a camera, a thermo-camera; an optical sensing apparatus including a light-emitting element that generates laser or far infrared rays and a light-receiving element that receives light emitted from this light-emitting element, and that senses a person on the basis of whether or not there is light sensed by the light-emitting element; a contactless sensing apparatus including a card having a radio-wave-type RFID tag carried by a person and a tag reader capable of long-distance communication with this radio-wave-type RFID tag.

In the case of the imaging apparatus, it is possible to determine a presence of a person and a position thereof by the controller **200** analyzing imaged data from the imaging apparatus.

In the case of the optical sensing apparatus, for example, a plurality of light-emitting elements is arranged in a matrix

on a ceiling, and a plurality of light-receiving elements is arranged in a matrix on a floor. Then, the controller **200** monitors output of the light-receiving elements and determines the light-receiving element whose output switches from an ON state to an OFF state. A position of the light-receiving element determined at this time corresponds to the position of the person.

In the case of the contactless sensing apparatus, for example, three or more tag readers are located to surround the floor. Each of the tag readers transmits to the controller **200** information of the read radio-wave-type RFID tag and information on a direction of the radio wave from the radio-wave-type RFID tag. The controller **200** determines a common position of the radio-wave-type RFID tags read by the three or more tag readers, on the basis of the information on the direction of the radio wave from the radio-wave-type RFID tag that is obtained from the three or more tag readers. The position of the radio-wave-type RFID tag determined at this time corresponds to the position of the person.

Although it is not an essential aspect, it is preferable that the radio-wave-type RFID tag and the tag reader be a tag and a tag reader of a microwave type. The microwave type tag and tag reader may read a relatively remote tag to the extent of a few meters. Therefore, by the radio-wave-type RFID tag and the tag reader each being the microwave type tag and tag reader, the radio-wave-type RFID tag may be read by a relatively small number of three or more tag readers. Therefore, a configuration of the tag reader may be made simpler.

In the case of the contactless sensing apparatus, a configuration may be such that three or more electromagnetic induction type tags and tag readers are used. The electromagnetic induction type tags and tag readers may be configured at a relatively low cost. By the contactless sensing apparatus having the configuration that the three or more electromagnetic induction type tags and tag readers are used, the contactless sensing apparatus may be configured at a relatively low cost.

In the case of the contactless sensing apparatus in which the three or more tag readers are located so as to surround the floor, for radio waves transmitted by the radio-wave-type RFID tags according to a transmit command from the tag reader, a position of the radio-wave-type RFID tag may be estimated by using a time span from transmission of the transmit command till reception of the radio wave by each of the three or more tag readers.

Use of the time span from the transmission of the transmit command till the reception of the radio wave allows for estimation of a distance from the tag reader to the radio-wave-type RFID tag. Therefore, use of the time span from the transmission of the transmit command till the reception of the radio wave by each of the three or more tag readers allows for estimation of each distance from each of the three or more tag readers to the radio-wave-type RFID tag. Use of the distances makes it possible to perform three-point positioning that estimates a target position using distances from three points positions of which are known.

Therefore, use of the time from the transmission of the transmit command till reception of the radio wave by each of the three or more tag readers allows for estimation of the position of the radio-wave-type RFID tag by means of the three-point positioning. This makes it possible to estimate a position of the radio-wave-type RFID tag even if the tag reader does not have a configuration to obtain the information on the direction of the radio wave from the radio-wave-type RFID tag.

A method of estimating the position of the radio-wave-type RFID tag using each of the time spans from the

transmission of the transmit command till the reception of the radio wave by the three or more tag readers is not specifically limited, and may be a method of estimating a target position by a prior-art radar apparatus having three or more receiving antennas, for example.

A procedure to estimate the position of the radio-wave-type RFID tag using each of the time spans from the transmission of the transmit command till the reception of the radio wave by each of the three or more tag readers may estimate the position of the radio-wave-type RFID tag using information on a difference between the time spans from the transmission of the transmit command till the reception of the radio wave by the respective three or more tag readers. The information is, for example, information exemplified by a phase difference and a frequency difference in the radio waves received by the three or more tag readers. This makes it possible to estimate the position of the radio-wave-type RFID tag using the information on the difference in the respective time spans, even if each of the time spans from the transmission of the transmit command till the reception of the radio wave by each of the three or more tag readers includes an error.

The method of estimating the position of the radio-wave-type RFID tag using the information on the difference in the respective time spans from the transmission of the transmit command till the reception of the radio wave by the three or more tag readers is not specifically limited, and may be, for example, the method of estimating the target position by the prior-art radar apparatus having the three or more receiving antennas.

Then, the controller **200** determines a position to form an air curtain depending on the position of the person and drives the plurality of blowers **11** and blowers **21** located at the position.

Although it is not an essential aspect, it is preferable that the air curtain apparatus have marker means capable of informing a passenger of a preferred boarding position. The preferred boarding position is, for example, a position where an air curtain is not formed. This makes it possible to provide the air curtain apparatus capable of preventing any passenger from boarding at an unfavorable position where the air curtain is formed, or the like, and more efficiently preventing mixing of foreign matters or the like. The marker means is not specifically limited and may be, for example, a mark indicating a boarding position posted on the ceiling, a mark indicating a boarding position posted on the floor, or the like. The mark is not specifically limited, and may be a mark including a picture, a figure, and/or a line or the like indicating a preferred boarding position in a case where passengers are divided and board.

Flowchart of Seventh Modification Example

FIG. **19** is a flowchart illustrating an example of preferable flow of a ventilation process to be performed by the controller **200** according to the seventh modification example. In the following, a description is given of the preferable flow of ventilation control to be performed by the controller **200**, with reference to FIG. **19**.

[Step 1: Position Sensing]

In cooperation with the storage unit **202** and the sensing apparatus **300**, the control unit **201** performs a process to sense information on a position of a person (step S1). The control unit **201** shifts the process to step S2. It is possible to use the sensed information to drive the plurality of blowers **11** and blowers **21** by performing the process to sense the information on a position of a person.

Means to sense a position is not specifically limited and may be any means to use means to sense various positions held by the sensing apparatus **300**. It is preferable that the means to sense a position be able to sense positions of a plurality of persons. This makes it possible to drive the plurality of blowers **11** and blowers **21** so as to prevent foreign matters from being mixed into a space where each of the plurality of persons is located, in accordance with the information on positions of the plurality of persons.

In a case where the sensing apparatus **300** includes the three or more tag readers capable of sensing the radio-wave-type RFID tag, it is preferable that the means to sense the position include a procedure to determine a position of a common radio-wave-type RFID tag read by the three or more tag readers, on the basis of information on directions of radio waves from the radio-wave-type RFID tag, the information being obtained from the three or more tag readers. As a result, the position of the radio-wave-type RFID tag may be determined, using an intersecting point where the respective directions of the obtained radio waves intersect.

In a case where the sensing apparatus **300** includes the three or more tag readers capable of sensing the radio-wave-type RFID tag, it is preferable that the means to sense the position include a procedure to estimate the position of the radio-wave-type RFID tag, using each of the time spans from the transmission of the transmit command to the reception of the radio wave by the three or more tag readers, for the radio waves transmitted by the radio-wave-type RFID tags according to the transmit command from the tag readers. This makes it possible to estimate the position of the radio-wave-type RFID tag using the three-point positioning. The procedure is not specifically limited, and may be a procedure including the means for the prior-art radar apparatus having the three or more antennas to estimate the target position.

In a case where the sensing apparatus **300** includes the three or more tag readers capable of sensing the radio-wave-type RFID tag, it is preferable that the means to sense the position include a procedure to estimate the position of the radio-wave-type RFID tag, using the information on the difference in the respective time spans from the transmission of the transmit command till the reception of the radio wave by the three or more tag readers. This makes it possible to estimate the position of the radio-wave-type RFID tag even if each of the time spans from the transmission of the transmit command till the reception of the radio wave by each of the three or more tag readers includes an error. The procedure is not specifically limited, and may be a procedure including the means for the prior-art radar apparatus having the three or more receiving antennas to estimate the target position.

It is preferable that the means to sense the position be able to obtain information on each of the plurality of persons. This makes it possible to drive the plurality of blowers **11** and blowers **21** so that the information on each of the plurality of persons is used to prevent foreign matters from being mixed into the space where each of the plurality of persons is located. The information on the person is not specifically limited.

The information on the person may be information that includes one or more of, for example, personal information exemplified by a person's name, contact information, height, age, an overseas travel record, and personal medical history or the like, group information that makes it possible to

identify a group to which a person belongs, or attribute information exemplified by a person's body temperature or the like.

[Step S2: Determination of Whether One or More Person are Sensed]

In cooperation with the storage unit **202**, the control unit **201** performs a process to determine whether or not one or more persons are sensed, on the basis of the position of the person sensed in step S1 (step S2). If the one or more persons are sensed, the control unit **201** shifts the process to step S3. If the one or more persons are not sensed, the control unit **201** shifts the process to step S1.

If the one or more persons are not sensed, it is preferable that the control unit **201** further perform a process to stop driving of the plurality of blowers **11** and blowers **21**. This makes it possible to reduce consumption of energy for generating an air curtain in a case where no person is sensed. [Step S3: Dividing Persons into Groups]

In cooperation with the storage unit **202**, the control unit **201** performs a process to divide persons into groups on the basis of the position of the person sensed in step S1 (step S3). The control unit **201** shifts the process to step S4. As a result, the plurality of persons may be divided into a plurality of groups in a case where the plurality of persons is sensed. In addition, in a case where one person is sensed, the one person is separated to one group. The process to divide persons into groups is not specifically limited.

It is preferable that the process to divide persons into groups include a process to assign a plurality of persons whose positions are close to each other into a same group. This makes it possible to prevent assignment to another group of the plurality of persons who are close to each other and any person of whom may be exposed to the wind when separated by an air curtain. Therefore, it is possible to prevent exposure of the person to wind in attempt to separate such a plurality of persons assigned to the other group by the air curtain.

It is preferable that the process to divide persons into groups include a process to divide persons into groups using the information related to a person. This makes it possible to obtain a group relationship of a plurality of persons using the information on the person and divide two or more persons of the plurality of persons who have the group relationship into a same group. The two or more persons having the group relationship are expected to be at positions close to each other. Therefore, it is possible to prevent such two or more persons from being exposed to wind in an attempt to separate them by the air curtain.

Although it is not the essential aspect, it is preferable that the controller **200** perform a process to guide to a predetermined position performed by step S4.

[Step S4: Guiding to Predetermined Position]

In cooperation with the storage unit **202**, the control unit **201** performs a process to guide so as to move to a predetermined position based on the groups divided in step S3 (step S4). The control unit **201** moves the process to step S5. This makes it possible to move the respective persons divided into the respective groups to positions where they are easily separated by the air curtain. Therefore, these groups and/or persons may be easily separated by the air curtain. Means to guide movement to the predetermined position is not specifically limited and may be the prior-art means to guide persons, exemplified by means using audio output and/or image display, or the like.

[Step S5: Forming Air Curtain]

In cooperation of the storage unit **202**, the plurality of blowers **11** and the plurality of blowers **21**, the control unit

201 performs a process to form the air curtain so as to separate the groups (step S5). The control unit **201** shifts the process to step S6. This makes it possible to form the air curtain and separate the groups. Therefore, foreign matters may be prevented from being mixed into a space corresponding to each of the groups, from outside of the space. The process to form the air curtain so as to separate the groups is not specifically limited.

It is preferable that the process to form the air curtain so as to separate the groups include a process to drive the plurality of blowers **11** and the plurality of blowers **21** that are adjacent to a cylindrical area. The cylindrical area has a central axis that passes through a periphery of the position of the person and is in a direction approximately coinciding with a vertical direction. As a result, a cylindrical air curtain that surrounds the person may be generated. This air curtain may prevent foreign matters from being mixed into a position away from the person.

It is preferable that the process to form the air curtain so as to separate the groups include a process to drive the plurality of blowers **11** and the plurality of blowers **21** that are adjacent to a cylindrical area. The cylindrical area has the central axis that passes through a position shifted by a predetermined distance from the position of the person in a traveling direction of the person and is in the direction approximately coinciding with the vertical direction. As a result, the cylindrical air curtain may be generated that surrounds the person according to the direction in which the person moves. This air curtain may further prevent mixing of foreign matters from the direction in which the person moves, while preventing foreign matters from being mixed from the position away from the person.

In a case where the cylindrical air curtains surrounding the plurality of persons are in contact with each other, it is preferable that the process to form the air curtain perform a process not to drive the plurality of blowers **11** and the plurality of blowers **21** included in an area which is inside of two or more cylindrical air curtains. This may prevent a person surrounded by the cylindrical air curtain from being exposed to the cylindrical air curtain that surrounds another person.

In a case where the process not to drive the plurality of blowers **11** and the plurality of blowers **21** surrounded by the area which is the inside of the two or more cylindrical air curtains is performed, it is preferable that for intersecting points where the two or more cylindrical air curtains intersect each other, the process to form the air curtain include a process to drive the plurality of blowers **11** and the plurality of blowers **21** that are in contact with two or more line segments connecting the intersecting points. As a result, even if the cylindrical air curtains surrounding the plurality of persons are in contact with each other, an air curtain may be formed so as to separate the plurality of persons from each other.

The process to form the air curtain so as to separate the groups may be a process including a procedure to drive one or more of the plurality of blowers **11** and the plurality of blowers **21** that are in contact with a perpendicular bisector of the line segment connecting two persons. This makes it possible to form a flat plate like air curtain in contact with the perpendicular bisector. This air curtain may prevent foreign matters from being mixed from a periphery of a person to that of another person.

It is preferable that the process to form the air curtain so as to separate the groups include a process to drive the plurality of blowers **11** and the plurality of blowers **21** in contact with the two or more cylindrical areas. The two or

more cylindrical areas have a central axis that passes through the periphery of the position of the person, passes through the periphery of the position of the person, and is in the direction approximately coinciding with the vertical direction. As a result, the cylindrical air curtain that multiply surrounds the person may be generated. This air curtain may further prevent foreign matters from being mixed from the position away from the person.

It is preferable that the process to form the air curtain so as to separate the groups include a process to drive the plurality of blowers **11** and the plurality of blowers **21** so as to form an air curtain that surrounds a specific area. As a result, an air curtain may be generated that surrounds a specific area where the person is frequently located, for example. This air curtain may further prevent mixing of foreign matters.

The specific area is not specifically limited, and may be, for example, an area where a person is located, the area being exemplified by a boarding area provided by dividing inside of an elevator, a working area of a surgeon, and a working area of an assistant, as well as surroundings of furniture exemplified by a table, a chair, a desk, a sofa, and a bed, and surroundings of equipment exemplified by an operating table, etc., or the like.

In a case where it is possible to drive the plurality of blowers **11** and plurality of blowers **21** so as to form the air curtain that surrounds the specific area, it is preferable that the process to form the air curtain so as to separate the groups include a process to drive the plurality of blowers **11** and the plurality of blowers **21** using the information on the person. As a result, the air curtain may be generated that surrounds the specific area where the person having specific information is frequently located, for example. This air curtain may further prevent mixing of foreign matters.

[Step S6: Position Sensing]

In cooperation with the storage unit **202** and the sensing apparatus **300**, the control unit **201** performs a process to sense information on the position of the person (step S6). The control unit **201** shifts the process to step S7. By performing the process to sense the information on the position of the person, it is possible to determine whether or not the person has moved, using the sensed information.

[Step S7: Determining Whether or not One or More Persons have Moved]

In cooperation with the storage unit **202**, the control unit **201** performs a process to determine whether or not one or more persons have moved, on the basis of each of the positions of the persons sensed in step S1 and step S6 (step S7). If the one or more persons have moved, the control unit **201** shifts the process to step S3. If the one or more persons have not moved, the control unit **201** ends the ventilation control and repeats the processes of step S1 to step S7. This makes it possible to form an air curtain according to the movement of the persons. Therefore, mixing of foreign matters may be further prevented.

Utilization Example 1 of Seventh Modification Example

FIG. **20** is an explanatory diagram schematically illustrating an example in which the seventh modification example is utilized in an elevator. The plurality of blowers **11** is arranged in a cross shape on the ceiling of an elevator car **500** and the plurality of blowers **21** is arranged in a cross shape on the floor. As a result, in a case where all of the plurality of blowers **11** and the plurality of blowers **21** is driven, inside of the elevator car **500** is divided into four areas by air curtains. In addition, it is possible to change

patterns of the air curtains by selecting the plurality of blowers **11** and the plurality of blowers **21** to be driven.

FIG. **21** is a top view illustrating patterns of the air curtain. FIG. **21** illustrates an example in which the inside of the elevator car **500** is divided into four areas (FIG. **21A**, for example), an example in which the inside is divided into three areas by dividing the back part into halves (FIG. **21B**, for example), an example in which the inside is divided into two parts of the front side and the back side (FIG. **21C**, for example), an example in which the inside is divided into right and left parts (FIG. **21D**, for example), and an example in which the inside is divided into a left back part and other parts (FIG. **21E**, for example), respectively. In this manner, combining a group of the blowers, which are arrayed from the center of the ceiling and that of the floor of the elevator car **500** in front-rear and right-left directions, makes it possible to change separation patterns by the air curtains, as illustrated in FIG. **21**. Consequently, it is possible to change the separation patterns by the air curtains to large, medium, or small, according to the number of persons in a group or a body shape.

In the usage example 1 of the seventh modification example, a description is given of a case where a contactless sensing apparatus is applied as the sensing apparatus **300**. The sensing apparatus **300** includes a contactless sensing apparatus including tag readers **301** to **303** and a radio-wave-type RFID tag **310**. In the radio-wave-type RFID tag **310** is registered in advance various types of information including a card number uniquely assigned to each of the radio-wave-type RFID tags **310**, personal information that allows for identification of an owner of the radio-wave-type RFID tag **310**, group information that allows for identification of a group relationship such as company colleagues, family members, or friends, and attribute information which is characteristic information on the owner of the radio-wave-type RFID tag **310**.

The personal information includes a name or contact information or the like, for example. The group information includes a group identification number automatically assigned to each group. More specifically, a same group identification number is stored in radio-wave-type RFID tags **310** of persons belonging to a same group. The attribute information is appropriately registered according to a purpose of use of a building having the elevator that utilizes the seventh modification example. For example, in a case where the building is a hospital, as the attribute information, job types such as a doctor, a nurse, or other staff members are stored for a person who works at the hospital, or for a patient, information such as whether he or she has returned from abroad in two weeks, whether he or she has a pre-existing disease, or whether his or her body temperature is 37.5 degrees or higher is stored. In addition, in a case where a building is a hall in which a theatrical play or a lecture takes place, as the attribute information, information such as a theatrical group name, a height or age, or a role is stored for a theatrical group member; for a speaker of the lecture, information identifying that he or she is the speaker is stored; or for a spectator, information identifying that he or she is the spectator is stored.

The tag readers **301** are arranged inside the elevator car **500**, and the tag readers **302** and **303** are arranged at an entrance of the elevator. Inside the elevator car, the tag readers **301** are arranged at four corners at a height near a person's chest, for example. At the entrance to the elevator are arranged the tag reader **302** and the tag reader **303**.

The tag readers **301** wirelessly communicate with the radio-wave-type RFID tags **310** of those who board the

elevator car **500** to read the personal information from the radio-wave-type RFID tag **310**, requests information on receiving directions of radio waves from the radio-wave-type RFID tags **310**, and transmits the information to the controller **200**.

The tag readers **302** read the radio-wave-type RFID tag possessed by those who line in front of the entrance of the elevator while waiting to board the elevator. The tag reader **303** reads the radio-wave-type RFID tags possessed by those who intend to board the elevator car **500**. The tag readers **302** and the tag reader **303** transmit the read information to the controller **200**.

Hereinafter, a description is given of control by the controller **200**.

On the basis of the group information read by the tag readers **302** from the radio-wave-type RFID tags **310**, the controller **200** determines a group relationship among the persons waiting for boarding to decide on a pattern of an air curtain and determines areas of the inside of the elevator car **500** where the persons are to board. The controller **200** determines to have persons having a group relationship board in the same area, whenever possible.

When the elevator car **500** arrives and its door opens and every time those who are waiting board one by one, the tag reader **303** reads the group information from the radio-wave-type RFID tag **310**, and the controller **200** drives and controls a guiding apparatus **320** on the basis of the information read by the tag reader **303**. The guiding apparatus **320** performs audio output or screen display to guide those who intend to board, on an area inside of the elevator car **500** to board.

Then, after passengers get in the elevator car **500** and the entrance door closes, the tag readers **301** inside the elevator car read passengers' radio-wave-type RFID tags **310** and transmits to the controller **200** requesting information on directions of the passengers with respect to the tag readers **301**. The controller **200** obtains the identification numbers and the personal information from the radio-wave-type RFID tags **310** of the persons on board. The controller **200** further determines a position of each passenger on board on the basis of the information on the receiving directions from the four tag readers **301**. In a case where the controller **200** determines that the passenger is located as he or she has been guided, the controller **200** drives the plurality of blowers **11** and the blowers **21** so that a predetermined pattern of the air curtain is formed.

Hereinafter, a description is given of the utilization example 1 of the seventh modification example in more detail, by way of an example of a hospital elevator.

First, as a premise, it is assumed that hospital staff members and patients each carry a card with the radio-wave-type RFID tag **310**. A new patient or a visitor is given the card with radio-wave-type RFID tag **310** at a reception desk at the entrance of the building. For example, if there is a plurality of visitors, a same group identification number is stored in the cards given to the plurality of visitors.

In FIG. **20**, five persons, Person A to Person E, line in front of the elevator. The tag reader **303** reads the radio-wave-type RFID tags **310** of the five persons, thereby determining a group relationship among Person A to Person E. For example, suppose that Person A or Person B has no group relationship with others, and that Person C, Person D, and Person E have the group relationship. In this case, the controller **200** determines that the air curtain illustrated in FIG. **21B** is suited, and decides to locate Person A in the left back part, Person B in the right back part, Person C in the left front part, Person D in the right front part, and Person E

in the center front part as illustrated in FIG. 21F. Then, when the elevator door opens and they board one by one, the tag readers 302 read the radio-wave-type RFID tag 301 of Person A. Then, the controller 200 controls the guiding apparatus 320 and causes the guiding apparatus 320 to perform the audio output or display screen guiding Person A to be located in the left back part. The same applies to Person B to Person E.

Then, after all of the persons has boarded the elevator car 500, the four tag reader 301 reads the radio-wave-type RFID tags 310 in the elevator car 500 and transmits to the controller 200 the card numbers, the personal information, and the information on the receiving directions of the radio waves. The controller 200 determines the positions of Person A to Person E on the basis of the information on the receiving directions that is transmitted from the four tag readers 301. That is to say, in a case where three-dimensional coordinates of a vertical axis (X axis), a horizontal axis (Y axis) and a height axis (Z axis) are assumed inside the elevator car 500, imaginary lines extend from the coordinates of the four tag readers 301 in the receiving directions and the coordinate where each of the imaginary lines intersects is a position of the radio-wave-type RFID tag 310. In addition, because the personal information is read from the radio-wave-type RFID tag 310, the controller 200 is able to understand who stands at which position in the elevator car 500.

In a case where the controller 200 confirms that Person A to Person E are located at the positions as guided, the controller 200 drives the plurality of blowers 11 and blowers 21 to form the air curtain having the pattern illustrated in FIG. 21B. In a case where the controller 200 confirms that Person A to Person E are not located at the positions as guided, the controller 200 determines an air curtain pattern that is most suited on the basis of the current positions of Person A to Person E, and drives the plurality of blowers 11 and blowers 21 so as to form the pattern.

Note that although the four tag readers 301 are arranged around the elevator car 500 in the example illustrated in FIG. 21, it is possible to measure of the position of the radio-wave-type RFID tag 310 as far as there are at least three tag readers 301.

In addition, in a case where an imaging apparatus or an optical sensing apparatus is applied as the sensing apparatus 300, the controller 200 receives sensing information from the sensing apparatus 300 to determine location of the persons after they board the elevator and the door closes. The controller 200 determines a pattern of an air curtain that suits this location and drives the plurality of blowers 11 and blowers 21 so as to form the pattern.

As such, according to the utilization example 1, in a case where a plurality of persons boards the elevator, it is possible to separate between a person and a person inside the elevator car 500. Consequently, if a person suffering from an infectious disease is included in the persons on board, that person is separated by an air curtain, which thereby makes it possible to prevent virus or the like from being transferred from that person to another person. Therefore, it is possible to prevent the spread of the infectious disease due to gathering of people in a closed space such as an elevator.

In addition, in a case where a plurality of persons on board has a group relationship, it is possible to determine their location inside the elevator so that the persons on board in that group gather in one area. Therefore, it is possible to relieve anxiety among the persons on board due to being in a closed space.

Note that in the utilization example 1, a priority may be given to location of the areas in the elevator where the persons board. For example, if the attribute information of one of the persons on board who have a group relationship includes information that "the person has the body temperature of 37.5° C.", that person is preferentially guided to the right back part of the elevator so that only he or she is surrounded by the air curtain for the small area.

In addition, in the case of a large elevator capable of accommodating a carrier that carries a patient, the plurality of blowers 11 and blowers 21 may be arranged in a grid pattern, rather than in the cross shape as illustrated in FIG. 20. In this case, the blowers 11 and the blowers 21 may be controlled in the unit of a grid, by controlling the blowers 11 and the blowers 21 in the unit of a side of each grid.

In addition, although the contactless sensing apparatus is applied as the sensing apparatus 300 in the utilization example 1 of the seventh modification example, an imaging apparatus may be used. For example, the controller 20 is provided with a face recognition capability and database in which the group information and the attribute information that are associated with the personal information of a person are stored. Then, the controller 200 identifies a person on the basis of a captured image and obtains the group information from the database. Furthermore, the controller 200 identifies a position of the person on the basis of the captured image. As such, it becomes possible for the controller 200 to obtain the group information and the positional information on the basis of the captured image from the imaging apparatus, which makes it possible to control the blowers 11 and the blowers 21 on the basis of the group information and the positional information of the person and to form the air curtain.

Although it is not an essential aspect, in the utilization example 1, location of the persons after the movement may be determined according to the movement of the persons on board in the elevator, an air curtain pattern suitable for the location of the persons after movement may be determined, and the plurality of blowers 11 and blowers 21 may be driven to form the pattern. As a result, it is possible to provide an air curtain apparatus that is able to efficiently prevent foreign matters from being mixed according to location of persons on board and movement of the persons on board.

Utilization Example 2 of Seventh Modification Example

FIG. 22 is an explanatory diagram schematically illustrating an example in which the seventh modification example is utilized in a large hall such as a party space, a banquet hall, and an exhibition space. The plurality of blowers 11 is arranged in a matrix on the ceiling of the large hall and the plurality of blowers 21 is arranged in a matrix on the floor. A plurality of tag readers 301 is arranged on walls of the large hall. Note that in the utilization example 2 of the seventh modification example, similarly to the utilization example 1, a description is given of a case where the contactless sensing apparatus is applied as the sensing apparatus 300.

In addition, those who are given a card with a radio-wave-type RFID tag 31 similar to that in the utilization example 1 may enter the large hall. In addition, in the radio-wave-type RFID tag 310 of the utilization example 2 are stored a card number, personal information, group information, and attribute information similar to those in the radio-wave-type RFID tag 310 of utilization example 1.

In the utilization example 1, the blowers **11** and the blowers **21** are arranged in a cross shape on the ceiling and the floor. The controller **200** collectively controls the plurality of blowers **11** and blowers **21** in the unit of a line, the plurality of blowers **11** and blowers **21** making up four lines which form the cross shape.

In contrast to this, in the utilization example 2, the controller **200** is able to individually control the plurality of blowers **11** and blowers **21** arranged in a matrix. Consequently, by individually selecting the blowers **11** and the blowers **21** to be driven, it is possible to form various air curtains when viewed in a plan view.

First, the controller **200** reads the RFID tags **310** possessed by persons in the large hall by the tag readers **301** and identify the persons and their positions. Then, the controller **200** determines an air curtain pattern on the basis of location of the persons in the large hall. Then, by selecting and driving the plurality of blowers **11** and blowers **22** corresponding to this pattern, the air curtain is formed in the large hall. Furthermore, the controller **200** drives the tag reader **301** at predetermined time intervals (once per second, for example) to read the RFID tags **310** possessed by the persons in the large hall, identify the persons and their positions, and thereby monitors movement of the persons. Then, the controller **200** changes the air curtain pattern according to the movement of the persons.

FIG. **23** is an explanatory diagram illustrating an example of forming an air curtain. After determining the position of the person, the controller **200** determines a circle having a radius r (1 m, for example) with this position as the center. A line thickness at this time is a diameter of the blower **21**. By extracting and driving the plurality of blowers **21** in contact with the circle thus determined and the plurality of blowers **11** corresponding thereto, a cylindrical air curtain covering the periphery of the person is formed. As illustrated in FIG. **23**, if the person moves, by driving the plurality of blowers **21** in contact with the circle having the radius r (1 m, for example) with a moving position as the center and the plurality of blowers **11** corresponding thereto, the cylindrical air curtain is formed.

Specifically, the controller **200** sets an XY coordinate system with respect to a floor surface and manages the position of the person and the position of the blower **21** by means of the XY coordinates. The controller **200** determines the XY coordinates at the position of the person on the basis of the sensing information from the sensing apparatus **300** and further assumes a circle which has a radius r with the XY coordinates of the person's position as the center and the line thickness of which is a diameter of the blower **21**. Then, the controller **200** lists up the blowers **21** that include the coordinates matching the coordinates of this circle. Then, by driving the plurality of blowers **21** listed and the plurality of blowers **11** corresponding thereto, the cylindrical air curtain is formed.

FIG. **24** is an explanatory diagram illustrating examples of forming an air curtain in a case where there is a plurality of persons. As illustrated in FIG. **24A**, in a case where a distance between Person A and Person B is longer than a radius $r \times 2$, cylindrical air curtains are formed with respective positions of Person A and Person B as the center.

As illustrated in FIG. **24B**, in a case where the distance between Person A and Person B is shorter than the radius $r \times 2$, a circle with the position of Person A as the center partially intersects that with the position of Person B as the center. In this case, the plurality of blowers **21** in contact with the circumferences of the two circles and the plurality of blowers **11** corresponding thereto are driven, and the

plurality of blowers **11** and the plurality of blowers **21** that correspond to a line (point p and point q in the figure) connecting two intersecting points (point p and point q in the figure) are also driven. This forms an air curtain having a shape in which parts of side surfaces of the two cylinders overlap.

As illustrated in FIG. **24C**, in a case where the distance between Person A and Person B is the radius $r \times 2$, an air curtain like a figure of eight in a plan view, in which parts of the side surfaces of the two cylinders abut, is formed.

FIG. **24D** is an example of forming air curtains among three persons, Person A, Person B, and Person C. In a case where air curtain patterns of Person A, Person B, and Person C have a common region, a center point of the region is determined. Then, the controller **200** forms an air curtain around Person A, Person B, and Person C, by driving not only the plurality of blowers **11** and the plurality of blowers **21** that are located at lines connecting points where Person A, Person B, and Person C intersect with each other and the center point, but also the plurality of blowers **11** and the plurality of blowers **21** corresponding to the outer circumferences of the three circles.

Note that in a case where the two persons illustrated in FIG. **24B** or the three persons illustrated in **24D** each have a group relationship, only the plurality of blowers **11** and the plurality of blowers **21** that correspond to the outer circumferences of the respective circles may be driven.

In addition, although the examples illustrated in FIG. **24A** to FIG. **24D** form the cylindrical air curtain, Person A and Person B may be separated by driving the plurality of blowers **11** and the plurality of blowers **21** which correspond to a perpendicular bisector of the line connecting the position of Person A and the position of Person B and by forming a flat plate like air curtain, as illustrated in FIG. **24E**.

It is to be noted that in a case a height or age is stored as attributes in an RFID tag **310** of a card possessed by a person, the radius of the air curtain may be automatically set according to the attributes, such as, setting the radius r to 1 m when the age is 10 years or older, setting the radius to 0.7 m when the age is less than 10 years, setting the radius r to 1.5 m if the height is 180 cm or higher, or the like.

In addition, although the air curtain is the single cylinder in the examples of forming illustrated in FIG. **24**, the air curtain may be made a double cylinder. Specifically, the controller **200** may be able to set, through operation on a menu screen by an administrator, whether to make an air curtain a single cylinder or a double cylinder, or whether to make the air curtain a single flat plate or a double flat plate, or furthermore, whether to make the radius larger or smaller, or the like. For example, in a case where a large hall is used as a medical facility, an air curtain is made a double cylinder when more caution is necessary, such as for a surgeon or a patient. By making an air curtain into a double cylinder in this manner, it becomes possible to create a space where no one is present between two air curtains, thus making it possible to separate the space more strictly. In addition, in a case where people move quickly and actively, in order to switch the air curtain more safely, it may be better to make an air curtain into a double cylinder where a buffer zone is set, or radius setting may be changed.

In addition, in a case where the large hall is utilized for a lecture, a theatrical play, a concert, or the like, it is possible to set a double cylinder or make a radius somewhat larger for a speaker or a player. Note that in this case, an air curtain for audience may be a single cylinder having a radius that is set normally.

FIG. 25 is an explanatory diagram illustrating another example of forming the air curtain in the utilization example 2. In the other example of forming, if a person enters a specific area, the plurality of blowers 11 and blowers 22, which are associated with the specific area and set in advance, are driven to from the air curtain.

For example, as illustrated in FIG. 25, a round table is placed in a large hall and a plurality of specific areas A to H are set at equal intervals around the round table. The controller 200 stores coordinate data corresponding to a range of the specific areas A to H. Furthermore, the controller stores the plurality of blowers 11 and blowers 21 that each correspond to the specific areas A to H. For example, the specific area A is associated with the plurality of blowers 11 and blowers 22 that are located between the specific area A and the specific area B. The specific area B is associated with the plurality of blowers 11 and blowers 21 located between the specific area B and the specific area C. Hereinafter, each of the specific areas is associated with the plurality of blowers 11 and blowers 21 similarly.

Then, the controller 200 monitors a position of a person in the large hall. When the person enters the specific areas A to H, the controller 200 drives the plurality of blowers 11 and blowers 21 that correspond to the respective specific areas A to H and forms an air curtain. FIG. 25 illustrates an example in which a person is present in each of the specific area A, B, D, and G. To the left of the person facing the table is formed an air curtain AC. Note that when a person sitting on a seat stands up and leaves the specific area, the controller 200 turns off the air curtain AC corresponding to the specific area.

Note that the group information of the RFID tag 310 of the cards possessed by the persons may be utilized so that those in a same group may sit on the seats of the round table. For example, an output apparatus of sound or images controllable by the controller 200 is placed on the round table. Then, when the controller 200 determines that a person of a different group enters the specific area, the controller drives the output apparatus to alert by image display or audio output or the like.

It is also possible to utilize the other examples of forming the air curtain in the above-mentioned utilization example 2 to individually separate chairs, desks, sofa, or the like located in a shared space of commercial facilities by an air curtain.

Utilization Example 3 of Seventh Modification Example

FIG. 26 is an explanatory diagram schematically illustrating an example in which the seventh modification example is utilized in a place, such as a cash desk or a ticket box office, where people line up. FIG. 26A is a lateral view and FIG. 26B is a top view. In the utilization example 3, similarly to the utilization example 2 illustrated in FIG. 22, blowers 11 and blowers 12 are arranged in a matrix on the ceiling and the floor, respectively.

A partition line is drawn at a position on the floor where people are to line up. The plurality of blowers 21 in contact with the partition line and the blowers 22 corresponding thereto are to be controlled by the controller 200. Note that although not illustrated in FIG. 25, the controller 200 and the sensing apparatus 300 illustrated in FIG. 18 are used in this utilization example. In addition, in this utilization example, an imaging apparatus is used as the sensing apparatus 300.

The controller 200 performs a person detection process from a captured image by the imaging apparatus and deter-

mines the person and his or her position. Then, the controller 200 selects the plurality of blowers 11 and the plurality of blowers 21 to be driven, and forms an air curtain between the ticket box office and the person in the front row, and between the person in the front row and the person in the back row by driving and controlling. The controller 200 performs control to stop the plurality of blowers 11 and the plurality of blowers 21 behind the person in the last row. Here, the controller may perform control to stop the plurality of blowers 11 and the plurality of blowers 21 when the people in line move and straddle the blowers 21.

Note that similarly to the utilization example 2, cylindrical air curtains may be formed by driving the plurality of blowers 11 and the plurality of blowers 21 arranged in a circle having a radius r of the people in line, as illustrated in FIG. 27. In this case, the center of the circle may be set at a position that is slightly offset forward in the traveling direction with respect to the positions of the people in line. As a result, when the position of the person in line moves to the traveling direction, the person approaches the center of the cylindrical air curtain, so that it is possible to prevent the person from going out of the air curtain.

In addition, similarly to the utilization example 2, a contactless sensing apparatus is applied as the sensing apparatus 300. If the controller 200 is able to obtain the group information, an air curtain may be formed around the group in a case where persons in the same group line up. For example, in FIG. 27, if two persons who line up after the first person in line belong to the same group, the air curtain may be formed around these two persons.

In addition, although in the utilization example 4, the blowers 11 and the blowers 21 are arranged in a matrix on the ceiling and the floor, respectively, similarly to the utilization example 2, the utilization example 3 is not limited to this, and the blowers 11 and the blowers 21 may be arranged in a grid pattern on the ceiling and the floor, respectively, as illustrated in FIG. 28. In this case, if people line up in a transverse direction with respect to the ticket office box, it becomes possible to separate the front and the back of the people in line, by driving some of the blowers 11 and the blowers 21 on the line in the lengthwise direction, as illustrated in FIG. 26B.

Utilization Example 4 of Seventh Modification Example

FIG. 29 is an explanatory diagram schematically illustrating an example in which the seventh modification example is utilized in a hospital. FIG. 29A illustrates a utilization example in an operating room, and FIG. 29B illustrates a utilization example in a hospital room. Note that although not illustrated in FIG. 29, the controller 200 and the sensing apparatus 300 illustrated in FIG. 18 are used in this utilization example. In the utilization example 3, the blowers 11 and the blowers 21 are arranged in a grid pattern on the ceiling and the floor, respectively, as illustrated in FIG. 28. Note that FIG. 29 illustrates only the blowers 21 to be controlled by the controller 200.

In addition, in the utilization example 4, an imaging apparatus is used as the sensing apparatus 300. Furthermore, a door sensor 330 is provided on a door that serves as an entrance/exit to the operating room or the hospital room. The door sensor 330 transmits to the controller 200 an ON signal when the door is open and an OFF signal when the door is closed.

As illustrated in FIG. 29A, in the operating room, the plurality of blowers 21 to be controlled by the controller 200

are arrayed on the floor so as to draw a rectangle that surrounds an operating table, a surgeon's working area, and an assistant's area, respectively. On the ceiling, the plurality of blowers **11** corresponding to the plurality of blowers **21** and to be controlled by the controller **200** are arrayed so as to draw a rectangle. In addition, a surgery start button **331** is provided in the operating room.

The surgery start button **331** is operated by the assistant. The surgery start button **331** enters an ON state when an operation starts, continues to be in the ON state during the operation, and enters an OFF state when the operation ends. The surgery start button **331** transmits to the controller **200** the ON signal during the ON state and OFF signal during the OFF state.

Then, on receipt of the ON signal from the door sensor **330** during a preset reserved period of the operating room, the controller **200** drives the blowers **11** and the blowers **21** corresponding thereto and forms an air curtain around the operating table, as illustrated in FIG. 29A. Here, if the controller **200** receives the ON signal from the door sensor **330** outside the reserved period of the operating room, the controller **200** does not drive the blowers **11** and the blowers **21** corresponding thereto, but if the controller **200** receives the ON signal from the surgery start button **33**, it forms the air curtain.

During the operation, the controller performs a process to detect surgical staff members present in the operating room, such as the surgeon and the assistant, or the like, from a captured image by the imaging apparatus, and determines positions of the surgical staff members. The controller **200** monitors movement of the surgical staff members on the basis of the captured image by the imaging apparatus. When the surgical staff member enters a specific area, the controller performs control to stop the specific blower **11** and the blower **21** corresponding thereto or to weaken an air volume.

For example, in the example illustrated in FIG. 29A, when a body part (hand, for example) of the surgeon or the surgical staff member or equipment straddles over the blower **21** between the surgeon and the surgical staff member, control is performed to stop or weaken this blower **21** and several blowers **21** adjacent to this blower **21** as well as the plurality of blowers **11** corresponding to these blowers **21**. This allows for adjustment to the air volume pressure that does not bother the surgeon or the assistant.

Then, after the operation ends, the assistant operates the surgery start button **331**. When the controller **200** receives the OFF signal from the surgery start button **331**, the blowers **11** and the blowers **21** stop and then the air curtain turns off.

As such, according to the utilization example 4, the periphery of the patient undergoing surgery is separated by the air curtain, and aerosol floating in the air is less likely to reach the patient undergoing surgery. Therefore, it is possible to improve the surgical environment.

Note that for the blowers **11** and the blowers **21** that form the air curtain between the surgeon and the assistant, the air volume may be set weaker in advance than other blowers **11** and blowers **21**. In addition, the surgical staff member may be able to adjust the air volume of the air curtain locally by operating the controller **200**.

As illustrated in FIG. 29B, in the hospital room, the plurality of blowers **21** is arrayed on the floor so as to draw a rectangle surrounding a bed. On the ceiling, the plurality of blowers **11** corresponding to the plurality of blowers **21** is arrayed so as to draw a rectangle. Note that although not illustrated in FIG. 29, the controller **200** and the sensing apparatus **300** illustrated in FIG. 18 are used in this utilization

example. In addition, in this utilization example, an imaging apparatus is used as the sensing apparatus **300**.

In the example illustrated in FIG. 29B, when the controller **200** receives the ON signal from the door sensor **330**, the sensing apparatus **300** starts operating. When the sensing apparatus **300** senses a person entering from the door, the controller **200** performs control to stop some of the blowers **21** around the bed and the corresponding blowers **11** or to weaken the air volume. Consequently, when a doctor comes to examine, or when a meal is served, it becomes possible to perform the examination or meal serving work at a location where there is no air curtain or where the air volume pressure is weak.

Note that in a case it is possible to recognize what kind of a person, such as a doctor, a nurse, a meal serving staff, a cleaning worker, a visitor, or the like, enters the hospital room, an air curtain suitable for that may be formed. For example, in the case of the cleaning worker, all air curtains may be turned off, and in the case of the visitor, the air curtain around a target of the visit may be turned off. It is possible to recognize a person entering the hospital room, by giving the person a card with the RFID tag, installing a tag reader at the entrance of the hospital room, causing the RFID tag to be read by the tag reader before the person enters the room, and further equipping the controller **200** with a so-called face recognition capability that identifies the person from an image captured by the imaging apparatus.

In addition, the blowers **21** surrounding the bed may be provided with a pressure sensor that senses airflow pressure of helical air currents from the blowers **11**, and ventilation may be automatically turned on or off when a drop in the airflow pressure is sensed. A contact sensor may be provided on the floor near the blowers **21** surrounding the bed, and ventilation may be automatically turned on or off when the contact sensor senses a contact. In addition, for example, in a case where the pressure sensor or the contact sensor senses any pressure or contact even though there is no one else than the patient in the hospital room, the patient or a nurse in charge may be notified, by sound or an image, of the possibility that an object is placed on the blower **21**.

As above, although description has been given of the utilization examples of the seventh modification example, the utilization examples of the seventh modification example are not limited to the above. For example, by making the sensing apparatus **300** act as a pressure sensor and installing this pressure sensor on a chair or a sofa, it is possible to sense whether or not there is any seated person. Then, when the person sits on the chair or the sofa, an air curtain may be formed between adjacent chairs or sofa, and when the person leaves the seat, the air curtain may be turned off.

For example, if a person waiting for a medical examination sits on a seat in a waiting room of a hospital, this makes it possible to separate him or her from a person seated next by the air curtain. In addition to the waiting room in the hospital, for example, in audience seats of a theater, it becomes possible to separate adjacent persons by an air curtain. Note that for adjacent seats, it is desirable to provide a buffer (buffer zone) where there is no one between seats, so that helical air currents from the blowers **11** flow to the blowers **21** between the adjacent seats.

In addition, in the utilization example 2, the air curtain patterns are changed according to the movement of the person. In the utilization example 2, however, the air curtain may be formed when the person enters the specific area, and the air curtain may be turned off when the person moves out of the specific area. For example, in a concert hall, when the sensing apparatus **300** senses that a conductor has gone up

to a conductor's podium, an air curtain may be formed around the conductor, and when the sensing apparatus 300 senses that the conductor has gone down the conductor's podium, the air curtain may be turned off.

In addition, although in the above-mentioned utilization examples of the seventh modification example, the examples are illustrated in which the blowers 11 and the blowers 21 are arranged in a cross shape, arranged in a matrix or in a grid pattern on the ceiling or floor, respectively, the arrangement patterns of the blowers 11 and the blowers 21 on the ceiling and the floor are not limited thereto. For example, the blowers 11 and the blowers 21 may be arranged in an arc shape as illustrated in FIG. 30A, or in a staggered grid pattern as illustrated in FIG. 30B, or in a honeycomb shape as illustrated in FIG. 30C. The arrangement of blowers 11 and the blowers 21 may be appropriately determined according to a purpose of use of a building. In particular, in a case where it is desired to form an air curtain in a rectangular tubular shape, it is desirable to array the blowers 11 and the blowers 21 in a grid pattern as illustrated in FIG. 28. In a case where it is desired to form an air curtain in a cylindrical shape, it is desirable to array the blowers 11 and the blowers 21 in a honeycomb shape as illustrated in FIG. 30C.

In addition, according to the seventh modification example, the air curtain is formed by helical air currents in the lengthwise direction from the ceiling toward the floor, but as in the air curtain apparatus illustrated in FIG. 1, it is also possible to use together an air curtain apparatus that forms an air curtain with helical air currents in the horizontal direction. As a result, it is possible to form various air curtains. In this case, the blowers 11 and 21 of the air curtain apparatus that forms an air curtain with the helical air currents in the lateral direction may be controllable by the controller 200. This makes it possible to form a preferred air curtain in various scenes. In addition, by attaching an RFID tag to the blowers 11 and the blowers 21, respectively, of the air curtain apparatus illustrated in FIG. 1, it becomes possible for the controller 200 to confirm positions of the blowers 11 and the blowers 21. As a result, when the position is displaced, it becomes possible for the controller 200 to stop the blowers 11 and the blowers 21 or promptly instruct a worker to adjust the position.

It is to be noted that any one type or a plurality of types of the air curtain apparatuses of the first modification example to the fifth modification example of the embodiment may be combined where appropriate.

As above, the invention made by the inventor has been specifically described on the basis of the embodiment thereof. It is needless to say, however, that the present invention is not limited to the above-mentioned embodiment, and various alterations may be made thereto without departing from the gist thereof.

Within the scope of the thought of the present invention, those skilled in the art may come up with various alterations and modifications, and it is understood that those alterations and modifications also fall within the present invention.

For example, the above-mentioned embodiment or the respective modification examples to which those skilled in the art appropriately have made additions, deletions, or design changes, or to which those skilled in the art have added, deleted, or changed a condition of a process also fall within the present invention as far as they have the gist of the present invention.

<Additional Statements>

The following is a brief description of the overview of a typical example of the embodiments described above.

An air curtain apparatus as one aspect of the present invention is an air curtain apparatus that forms an air curtain. The air curtain apparatus includes a plurality of first blowers being arrayed in an up-down direction and each including a first air inlet port in which air is sucked and a first air outlet port from which air is blown out; and a plurality of second blowers being arrayed in the up-down direction, each including a second air inlet port in which air is sucked and a second air outlet port from which air is blown out, and, in a plan view, the second air inlet port each facing the first air outlet port included in each of the plurality of first blowers. In a pair of the first blower and the second blower, the first blower blows out a helical air current from the first air outlet port included in the first blower toward the second air inlet port included in the second blower, and the second blower sucks in the helical air current blown out by the first blower from the second air inlet port included in the second blower. In addition, the air curtain apparatus forms the air curtain of a plurality of the helical air currents, the plurality of helical air currents being blown out from the plurality of first air outlet ports each included in each of the plurality of first blowers and sucked into the plurality of second air inlet ports each included in each of the plurality of second blowers.

In addition, as another aspect, a third blower, which is any of the plurality of first blowers, may include a light emitting unit. The light emitting unit emits light in a direction in which the helical air current is blown out of the first air outlet port included in a third blower. Relative positions of the plurality of second blowers with respect to the plurality of first blowers may be adjusted so that light applied by the light emitting unit is applied to a fourth blower. The fourth blower is any of the plurality of second blowers and, in a plan view, includes the second air inlet port facing the first air outlet port included in the third blower.

In addition, as another aspect, the light emitting unit may be a laser or a light emitting diode that emits visible light or infrared light.

In addition, as another aspect, the fourth blower may also include a light receiving unit that receives light applied by the light emitting unit. Relative positions of the plurality of second blowers with respect to the plurality of first blowers may be adjusted so that light applied by the light emitting unit is applied to the light receiving unit.

In addition, as another aspect, the air curtain apparatus includes two air curtain forming units, each of which forms an air curtain. Each of the two air curtain forming units may have a plurality of first blowers and a plurality of second blowers. The plurality of second blowers held by a first air curtain forming unit, which is any of the two air curtain forming units, in a plan view, may be adjacent to the plurality of first blowers held by a second air curtain forming unit, which is different from the first air curtain forming unit of the two air curtain forming units. In a plan view, a direction from the plurality of first blowers held by the second air curtain forming unit toward the plurality of second blowers held by the second air curtain forming unit may differ from a direction from the plurality of first blowers held by the first air curtain forming unit toward the plurality of second blowers held by the first air curtain forming unit. The first air curtain forming unit may have a first connection unit that connects the plurality of second air outlet ports and the plurality of first air inlet ports in an airtight manner, each of the plurality of second air outlet ports being included in each of the plurality of second blowers held by the first air

curtain forming unit, and each of the plurality of first air inlet ports being included in each of the plurality of first blowers held by the second air curtain forming unit.

In addition, as another aspect, the air curtain apparatus may include N air curtain forming units (N being an integer of 3 or larger), the air curtain forming units being arrayed along an annular path around a central axis along the up-down direction and each forming an air curtain. Each of the N air curtain forming units may have a plurality of first blowers and a plurality of second blowers. For each of the N air curtain forming units, in a pair of a third air curtain forming unit and a fourth air curtain forming unit, in a plan view, the plurality of second blowers held by the third air curtain forming unit may be adjacent to a plurality of first blowers held by the fourth air curtain forming unit, the third air curtain forming unit being the air curtain forming unit, and the fourth air curtain forming unit, of the N air curtain forming units, being arranged on a first side which is, in a plan view, side of an anti-clockwise direction or that of a clockwise direction, along the annular path of the third air curtain forming unit, and the fourth air curtain forming unit being the air curtain forming unit adjacent to the third air curtain forming unit. The third air curtain forming unit may have a second connection unit that connects in an air-tight manner the plurality of second air outlet ports and the plurality of first air inlet ports in an airtight manner, the plurality of second air outlet ports each being included in each of the plurality of second blowers held by the third air curtain forming unit and the plurality of first air inlet ports each being included in each of the plurality of first blowers held by the fourth air curtain forming unit.

In addition, as another aspect, a rotation direction of the helical air current, when the helical air current blown out by the first blower is seen from the first blower, is a clockwise or anti-clockwise rotation direction, and may be the same rotation direction among the plurality of first blowers.

In addition, as another aspect, each of the plurality of first blowers includes a first cylinder part and a first fan provided inside the first cylinder part. The first air inlet port is provided at a first end in an axial direction of the first cylinder part. The first air outlet port is provided at a second end opposite to the first end, in the axial direction of the first cylinder part. The first fan may suck in air from the first air inlet port and blow out from the first air outlet port the air sucked in from the first air inlet port. Each of the plurality of first blowers may further include a first grille, the first grille being provided at the first air outlet port and having a plurality of holes formed therein, each having a helical shape swirling in a clockwise or anti-clockwise direction when viewed from the direction of the first cylinder part.

In addition, as another aspect, each of the plurality of first blowers may have a spraying unit that sprays an antiseptic solution inside the first cylinder part.

In addition, as another aspect, each of the plurality of second blowers includes a second cylinder part and a second fan provided inside the second cylinder part. The second air inlet port is provided at a third end in the axial direction of the second cylinder part. The second air outlet port is provided at a fourth end which is opposite to the third end in the axial direction of the second cylinder part. The second fan may suck in air from the second air inlet port and blow out from the second air outlet port the air sucked from the second air inlet port. An inner diameter of the second air inlet port may be larger than that of the first air outlet port.

In addition, as another aspect, each of the plurality of first blowers may include a first injection unit that injects a colored gas into the inside of the first cylinder part.

In addition, as another aspect, each of the plurality of first blowers may include a second injection unit that injects a gas containing a smell component into the inside of the first cylinder part.

With one aspect of the present invention applied, simply using a small and simple air curtain apparatus makes it possible to efficiently separate and divide a certain space and to efficiently prevent entry of foreign matters such as droplets or the like from one subspace to the other subspace.

INDUSTRIAL APPLICABILITY

The present invention is effective when applied to an air curtain apparatus that forms an air curtain.

DESCRIPTION OF THE REFERENCE NUMERALS

- 1 Air curtain apparatus
- 2, 2a-2d Air curtain forming unit
- 3 Air outlet unit
- 4 Air inlet unit++
- 11, 11a, 21, 21a Blower
- 12, 22 Support part
- 13, 23 Air inlet port
- 14, 24 Air outlet port
- 15, 25 Leg
- 16, 26 Frame part
- 31, 41, AX1 Central axis
- 32, 42 Cylinder part
- 33, 43 Fan
- 34, 44 Drive unit
- 35, 36, 45, 46 End
- 51 Table
- 52 User
- 53 Employee
- 54, 55 Table group
- 56 Aisle
- 57 Partition
- 61 Light emitting unit
- 62 Light receiving unit
- 63 Grille
- 63a Hole
- 64 to 66 Connection unit
- 71 Spraying unit
- 71a Antiseptic solution
- 72, 73 Injection unit
- 80 Identification apparatus
- 81 Stretching part
- 82 Placement part
- 83 Strip-shaped member
- 84 Storing body
- 86 Drawer port
- 87 Recess

-
- 87a Groove part
 - 90 Scope unit
 - 91 Scope
 - 92 Support
 - 93 Long member
 - 94 Short member
 - 95 Hinge
 - 96 Rod member
 - 97 Placement part
 - 100 Member
 - 101 Bag body
 - 102 Thread-like member

-continued

103	Spring member
200	Controller
201	Control unit
202	Storage unit
300	Sensing apparatus
301, 302, 303	Tag reader
310	RFID tag
320	Guiding apparatus
330	Door sensor
331	Surgery start button
500	Elevator car
AC1, AC10, AC11, AC12	Air curtain
AC2	Annular air curtain
AR1	Area

- CR1 Circular route
- GS1, GS2 Gas
- ID1, ID2 Inside diameter
- LG1 Light
- SA1 Helical air current
- SP Space
- SP1, SP2 Subspace

The invention claimed is:

1. An air curtain apparatus that forms an air curtain, comprising:
 - a plurality of first blowers that is arrayed in an up-down direction, and each include a first air inlet port in which air is sucked in and a first air outlet port from which the air is blown out; and
 - a plurality of second blowers that is arrayed in the up-down direction, each includes a second air inlet port in which air is sucked in and a second air outlet port from which the air is blown out, and, in a plan view, the second air inlet port each faces the first air outlet port included in each of the plurality of first blowers, wherein
 - in a pair of the first blower and the second blower, the first blower blows out a helical air current from the first air outlet port included in the first blower toward the second air inlet port included in the second blower, the second blower sucks in the helical air current blown out by the first blower from the second air inlet port included in the second blower, and
 - the air curtain apparatus forms the air curtain of a plurality of the helical air currents, the plurality of helical air currents being blown out from the plurality of first air outlet ports each included in each of the plurality of first blowers and sucked into the plurality of second air inlet ports each included in each of the plurality of second blowers, and
- wherein
 - a third blower, which is any of the plurality of first blowers, includes a light emitting unit, the light emitting unit emitting light in a direction in which the helical air current is blown out from the first air outlet port included in the third blower, and
 - relative positions of the plurality of second blowers with respect to the plurality of first blowers are adjusted so that light applied by the light emitting unit is applied to a fourth blower, the fourth blower being any of the plurality of second blowers and, in a plan view, including the second air inlet port facing the first air outlet port included in the third blower.
2. The air curtain apparatus according to claim 1, wherein the light emitting unit is a laser or a light emitting diode that emits visible light or infrared light.

3. The air curtain apparatus according to claim 1, wherein the fourth blower includes a light receiving unit that receives light applied by the light emitting unit, and relative positions of the plurality of second blowers with respect to the plurality of first blowers are adjusted so that light applied by the light emitting unit is applied to the light receiving unit.
4. The air curtain apparatus according to claim 1, wherein a rotation direction of the helical air current, when the helical air current blown out by the first blower is seen from the first blower, is a clockwise or anti-clockwise rotation direction, and may be the same rotation direction among the plurality of first blowers.
5. The air curtain apparatus according to claim 1, wherein each of the plurality of first blowers includes:
 - a first cylinder part, and
 - a first fan provided inside the first cylinder part, wherein the first air inlet port is provided at a first end in an axial direction of the first cylinder part, the first air outlet port is provided at a second end opposite to the first end, in the axial direction of the first cylinder part, the first fan sucks in air from the first air inlet port and blows out from the first air outlet port the air sucked in from the first air inlet port, each of the plurality of first blowers further includes a first grille, the first grille being provided at the first air outlet port and having a plurality of holes formed therein, each having a helical shape swirling in a clockwise or anti-clockwise direction when viewed from the direction of the first cylinder part.
6. The air curtain apparatus according to claim 5, wherein each of the plurality of first blowers includes a spraying unit that sprays an antiseptic solution inside the first cylinder part.
7. The air curtain apparatus according to claim 5, wherein each of the plurality of second blowers includes:
 - a second cylinder part, and
 - a second fan provided inside the second cylinder part, wherein the second air inlet port is provided at a third end in the axial direction of the second cylinder part, the second air outlet port is provided at a fourth end which is opposite to the third end in the axial direction of the second cylinder part, the second fan sucks in air from the second air inlet port and blows out from the second air outlet port the air sucked from the second air inlet port, and an inner diameter of the second air inlet port is larger than an inside diameter of the first air outlet port.
8. The air curtain apparatus according to claim 5, wherein each of the plurality of first blowers includes a first injection unit that injects a colored gas into the inside of the first cylinder part.
9. The air curtain apparatus according to claim 5, wherein each of the plurality of first blowers includes a second injection unit that injects a gas containing a smell component into the inside of the first cylinder part.
10. An air curtain apparatus that forms an air curtain, comprising:
 - a plurality of first blowers that is arrayed in an up-down direction, and each include a first air inlet port in which air is sucked in and a first air outlet port from which the air is blown out; and
 - a plurality of second blowers that is arrayed in the up-down direction, each includes a second air inlet port in which air is sucked in and a second air outlet port from which the air is blown out, and, in a plan view, the

second air inlet port each faces the first air outlet port included in each of the plurality of first blowers, wherein

in a pair of the first blower and the second blower, the first blower blows out a helical air current from the first air outlet port included in the first blower toward the second air inlet port included in the second blower,

the second blower sucks in the helical air current blown out by the first blower from the second air inlet port included in the second blower, and

the air curtain apparatus forms the air curtain of a plurality of the helical air currents, the plurality of helical air currents being blown out from the plurality of first air outlet ports each included in each of the plurality of first blowers and sucked into the plurality of second air inlet ports each included in each of the plurality of second blowers, and

wherein the air curtain apparatus comprises

N air curtain forming units (N being an integer of 3 or larger), the air curtain forming units being arrayed along an annular path around a central axis along the up-down direction and each forming an air curtain, wherein each of the N air curtain forming units includes:

a plurality of first blowers, and
a plurality of second blowers,

wherein for each of the N air curtain forming units, in a pair of a third air curtain forming unit and a fourth air curtain forming unit, in a plan view, the third air curtain forming unit being the air curtain forming unit, and the fourth air curtain forming unit, of the N air curtain forming units, being arranged on a first side which is, in a plan view, side of an anti-clockwise direction or side of a clockwise direction, along the annular path of the third air curtain forming unit, and the fourth air curtain forming unit being the air curtain forming unit adjacent to the third air curtain forming unit,

the plurality of second blowers held by the third air curtain forming unit is adjacent to a plurality of first blowers held by the fourth air curtain forming unit, the third air curtain forming unit has a second connection unit that connects in an air-tight manner the plurality of second air outlet ports and the plurality of first air inlet ports in an airtight manner, the plurality of second air outlet ports each being included in each of the plurality of second blowers held by the third air curtain forming unit and the plurality of first air inlet ports each being included in each of the plurality of first blowers held by the fourth air curtain forming unit.

11. An air curtain apparatus that forms an air curtain, comprising:

a plurality of first blowers that is arrayed in an up-down direction, and each include a first air inlet port in which air is sucked in and a first air outlet port from which the air is blown out; and

a plurality of second blowers that is arrayed in the up-down direction, each includes a second air inlet port in which air is sucked in and a second air outlet port from which the air is blown out, and, in a plan view, the second air inlet port each faces the first air outlet port included in each of the plurality of first blowers,

wherein

in a pair of the first blower and the second blower, the first blower blows out a helical air current from the first air outlet port included in the first blower toward the second air inlet port included in the second blower,

the second blower sucks in the helical air current blown out by the first blower from the second air inlet port included in the second blower, and

the air curtain apparatus forms the air curtain of a plurality of the helical air currents, the plurality of helical air currents being blown out from the plurality of first air outlet ports each included in each of the plurality of first blowers and sucked into the plurality of second air inlet ports each included in each of the plurality of second blowers, and

wherein

at least any one of the first blower and the second blower further comprises an identification member that makes it possible to visually identify a traveling direction of the helical air current,

the identification member includes a strip-shaped member, a storing part that stores the strip-shaped member in a rolled-up state, and a placement part in which the strip-shaped member is drawn from the storing part is placed, and

in a case where the strip-shaped member is drawn from the storing part, the strip-shaped member is maintained in a state in which the strip-shaped member is extended along the traveling direction of the helical air current.

12. An air curtain apparatus that forms an air curtain, comprising:

a plurality of first blowers that is arrayed in an up-down direction, and each include a first air inlet port in which air is sucked in and a first air outlet port from which the air is blown out; and

a plurality of second blowers that is arrayed in the up-down direction, each includes a second air inlet port in which air is sucked in and a second air outlet port from which the air is blown out, and, in a plan view, the second air inlet port each faces the first air outlet port included in each of the plurality of first blowers,

wherein

in a pair of the first blower and the second blower, the first blower blows out a helical air current from the first air outlet port included in the first blower toward the second air inlet port included in the second blower, the second blower sucks in the helical air current blown out by the first blower from the second air inlet port included in the second blower, and

the air curtain apparatus forms the air curtain of a plurality of the helical air currents, the plurality of helical air currents being blown out from the plurality of first air outlet ports each included in each of the plurality of first blowers and sucked into the plurality of second air inlet ports each included in each of the plurality of second blowers, and

wherein

at least any one of the first blower and the second blower further comprises an identification member that makes it possible to visually identify the traveling direction of the helical air current,

the identification member includes a strip-shaped member, being deformable in any of an elongated state in which a plurality of short members is connected and a folded state; and a placement part in which a predetermined region of the strip-shaped member in the elongated state is placed, and

the strip-shaped member extends along the traveling direction of the helical air current in the elongated state.

13. An air curtain apparatus that forms an air curtain, comprising:

a plurality of first blowers that is arrayed in an up-down direction, and each include a first air inlet port in which air is sucked in and a first air outlet port from which the air is blown out; and

a plurality of second blowers that is arrayed in the up-down direction, each includes a second air inlet port in which air is sucked in and a second air outlet port from which the air is blown out, and, in a plan view, the second air inlet port each faces the first air outlet port included in each of the plurality of first blowers,

wherein

in a pair of the first blower and the second blower, the first blower blows out a helical air current from the first air outlet port included in the first blower toward the second air inlet port included in the second blower, the second blower sucks in the helical air current blown out by the first blower from the second air inlet port included in the second blower, and

the air curtain apparatus forms the air curtain of a plurality of the helical air currents, the plurality of helical air currents being blown out from the plurality of first air outlet ports each included in each of the plurality of first blowers and sucked into the plurality of second air inlet ports each included in each of the plurality of second blowers, and

wherein

at least any one of the first blower and the second blower further comprises an identification member that makes it possible to visually identify the traveling direction of the helical air current,

the identification member comprises a stretchable member including a plurality of cylindrical members of varying diameters arranged concentrically, and a placement part where a predetermined region of the stretchable member in a stretched state is placed, and

the stretchable member extends along the traveling direction of the helical air current in the stretched state.

14. An air curtain apparatus that forms an air curtain, comprising:

a plurality of first blowers that is arrayed in an up-down direction, and each include a first air inlet port in which air is sucked in and a first air outlet port from which the air is blown out; and

a plurality of second blowers that is arrayed in the up-down direction, each includes a second air inlet port in which air is sucked in and a second air outlet port from which the air is blown out, and, in a plan view, the second air inlet port each faces the first air outlet port included in each of the plurality of first blowers,

wherein

in a pair of the first blower and the second blower, the first blower blows out a helical air current from the first air outlet port included in the first blower toward the second air inlet port included in the second blower, the second blower sucks in the helical air current blown out by the first blower from the second air inlet port included in the second blower, and

the air curtain apparatus forms the air curtain of a plurality of the helical air currents, the plurality of helical air currents being blown out from the plurality of first air outlet ports each included in each of the plurality of first blowers and sucked into the plurality of second air inlet ports each included in each of the plurality of second blowers, and

wherein

at least any one of the first blower and the second blower further comprises an identification member that makes it possible to visually identify the traveling direction of the helical air current,

the identification member comprises a scope unit, the scope unit being arranged in one of the first blower and the second blower and capable of visually recognizing an object present in a direction along the traveling direction of the helical air current.

15. An air curtain apparatus that forms an air curtain, comprising:

a plurality of first blowers that is arrayed in an up-down direction, and each include a first air inlet port in which air is sucked in and a first air outlet port from which the air is blown out; and

a plurality of second blowers that is arrayed in the up-down direction, each includes a second air inlet port in which air is sucked in and a second air outlet port from which the air is blown out, and, in a plan view, the second air inlet port each faces the first air outlet port included in each of the plurality of first blowers,

wherein

in a pair of the first blower and the second blower, the first blower blows out a helical air current from the first air outlet port included in the first blower toward the second air inlet port included in the second blower, the second blower sucks in the helical air current blown out by the first blower from the second air inlet port included in the second blower, and

the air curtain apparatus forms the air curtain of a plurality of the helical air currents, the plurality of helical air currents being blown out from the plurality of first air outlet ports each included in each of the plurality of first blowers and sucked into the plurality of second air inlet ports each included in each of the plurality of second blowers, and

wherein

at least any one of the first blower and the second blower further comprises an identification member that makes it possible to visually identify the traveling direction of the helical air current,

the identification member comprises an elongated bag-shaped member, a base end of the elongated bag-shaped member being opened and a termination of the elongated bag-shaped member being closed; and a linear spring member fixed to the bag-shaped member and deforming the bag-shaped member into a wrapped state, and

the bag-like member is arranged so that the base end faces the first blower and extends along the traveling direction of the helical air current, by air from the first blower flowing in from the base end.

16. An air curtain apparatus that forms an air curtain, comprising:

a plurality of first blowers that is arrayed in an up-down direction, and each include a first air inlet port in which air is sucked in and a first air outlet port from which the air is blown out; and

a plurality of second blowers that is arrayed in the up-down direction, each includes a second air inlet port in which air is sucked in and a second air outlet port from which the air is blown out, and, in a plan view, the second air inlet port each faces the first air outlet port included in each of the plurality of first blowers,

wherein
 in a pair of the first blower and the second blower,
 the first blower blows out a helical air current from the
 first air outlet port included in the first blower toward
 the second air inlet port included in the second blower,
 the second blower sucks in the helical air current blown
 out by the first blower from the second air inlet port
 included in the second blower, and
 the air curtain apparatus forms the air curtain of a
 plurality of the helical air currents, the plurality of
 helical air currents being blown out from the plural-
 ity of first air outlet ports each included in each of the
 plurality of first blowers and sucked into the plurality
 of second air inlet ports each included in each of the
 plurality of second blowers, and

wherein
 the air curtain apparatus has a controller that drives and
 controls the first blower and the second blower,
 the plurality of first blowers is juxtaposed in an upper part
 of an indoor space, and
 the plurality of second blowers is juxtaposed in a lower
 part of an indoor space, wherein in the plurality of first
 blowers and the plurality of second blowers, the con-
 troller selects a plurality of predetermined pairs, the
 predetermined pairs being pairs of predetermined first
 blowers of the plurality of first blowers and predeter-
 mined second blowers facing the predetermined first
 blowers, and drives and controls the selected first
 blowers and second blowers.

17. The air curtain apparatus according to claim 16,
 wherein
 the air curtain apparatus further includes a position sens-
 ing apparatus that senses a position of a mobile object
 in the indoor space, and
 the controller obtains positional information of a mobile
 object from the position sensing apparatus, selects the
 plurality of the predetermined pairs that are located at
 a certain distance from the mobile object, and drives
 and controls the first blower and the second blower that
 constitute the selected predetermined pairs.

18. The air curtain apparatus according to claim 17,
 wherein
 the plurality of first blowers and the plurality of second
 blowers are arranged in a matrix in the indoor space.

19. The air curtain apparatus according to claim 18,
 wherein
 the controller selects a plurality of the predetermined pairs
 located in a predetermined radius from the mobile
 object, and forms a cylindrical air curtain surrounding
 the mobile object.

20. The air curtain apparatus according to claim 17,
 wherein
 the plurality of first blowers and the plurality of second
 blowers are arranged in a grid pattern in the indoor
 space.

21. The air curtain apparatus according to claim 20,
 wherein
 the controller is able to collectively select the plurality of
 first blowers and the plurality of second blowers
 aligned on an individual line of four lines that form one
 grid.

22. The air curtain apparatus according to claim 17,
 wherein
 the controller forms an air curtain surrounding a plurality
 of mobile objects in a case where the plurality of
 mobile objects sensed by the position sensing apparatus
 mutually has a group relationship, and a distance
 between the respective mobile objects is closer than a
 predetermined distance.

23. The air curtain apparatus according to claim 17,
 wherein
 the controller updates the positional information for every
 predetermined period, and selects the plurality of pre-
 determined pairs on the basis of the updated positional
 information.

24. The air curtain apparatus according to claim 17,
 wherein
 the controller selects the plurality of predetermined pairs,
 the predetermined pairs being able to configure an air
 curtain that separates only a specific mobile object in a
 case where there is the specific mobile object for one or
 more mobile objects located at a position correspond-
 ing to the positional information obtained by the posi-
 tion sensing apparatus,
 the controller drives and controls the first blower and the
 second blower that constitute the selected predeter-
 mined pair, and
 the second blower sucks in, from the second air inlet port
 included in the second blower, the helical air current
 blown out from the first blower located vertically
 above.

25. The air curtain apparatus according to claim 24,
 further including:
 guide means that is able to guide to a specific position in
 the certain space with respect to the specific mobile
 object.

26. The air curtain apparatus according to claim 16,
 further including:
 marker means that is able to notify a position that differs
 from a position of an air curtain formed in a direction
 from the first blower to the second flower, the first
 blower and the second blower being selected by the
 controller.

* * * * *