



US011626715B2

(12) **United States Patent**  
**Carroccia et al.**

(10) **Patent No.:** **US 11,626,715 B2**  
(45) **Date of Patent:** **Apr. 11, 2023**

(54) **CORD PROTECTOR**

(56) **References Cited**

(71) Applicant: **On Top Safety Equipment, LLC**,  
Cheektowaga, NY (US)  
(72) Inventors: **John J. Carroccia**, Orchard Park, NY  
(US); **Jeffrey L. Murray**, Hamburg,  
NY (US)  
(73) Assignee: **On Top Safety Equipment, LLC**,  
Cheektowaga, NY (US)  
(\* ) Notice: Subject to any disclaimer, the term of this  
patent is extended or adjusted under 35  
U.S.C. 154(b) by 0 days.

U.S. PATENT DOCUMENTS

817,557 A *	4/1906	Hatherly et al. ....	F16G 11/00 24/129 R
1,668,953 A *	5/1928	Erickson .....	H02G 3/0487 174/101
2,831,049 A *	4/1958	Cabral .....	H01B 7/0815 427/119
2,960,561 A *	11/1960	Plummer .....	A44B 19/16 24/399
2,963,676 A	12/1960	Sneesby	
3,003,794 A *	10/1961	Burley .....	H02G 3/0608 174/101
3,082,984 A *	3/1963	Larsson .....	F16L 3/13 174/72 A
3,180,923 A *	4/1965	Gow .....	H02G 3/0487 174/DIG. 11
3,183,302 A	5/1965	Wochner	
3,391,244 A *	7/1968	Moll .....	H02G 7/16 174/40 R

(21) Appl. No.: **17/445,895**

(22) Filed: **Aug. 25, 2021**

(65) **Prior Publication Data**  
US 2023/0067186 A1 Mar. 2, 2023

(51) **Int. Cl.**  
**H02G 3/04** (2006.01)  
(52) **U.S. Cl.**  
CPC ..... **H02G 3/0487** (2013.01); **H02G 3/0406**  
(2013.01)

(58) **Field of Classification Search**  
CPC ..... H02G 3/0487; H02G 3/263; H02G 11/00;  
H02G 3/04; H02G 3/22; H02G 1/1256;  
H02G 15/184; H02G 3/10; H02G 3/26;  
H02G 3/38; H02G 1/02; H02G 1/12;  
F16L 3/233; E05D 11/0081; H01B  
7/0045  
USPC ..... 174/68.3  
See application file for complete search history.

(Continued)  
*Primary Examiner* — Krystal Robinson  
(74) *Attorney, Agent, or Firm* — Simpson & Simpson,  
PLLC

(57) **ABSTRACT**  
A cord protector detachably securable to an object includes a main body having at least one channel disposed therein that extends along a portion of a longitudinal length of the main body and the channel is capable of receiving and securing a cord, line, or tube therein. The cord protector further includes a clamping/gripping mechanism formed of a pair of oppositely disposed clamping/gripping arms that extend from opposite sides of the main body, which are biased toward one another such that the clamping/gripping arms maintain a substantially closed position at rest. The cord protector is capable of being detachably secured to the object by opening the clamping/gripping arms against the bias and allowing the clamping/gripping arms to return toward the resting position such that they close and clamp upon the object.

**16 Claims, 9 Drawing Sheets**

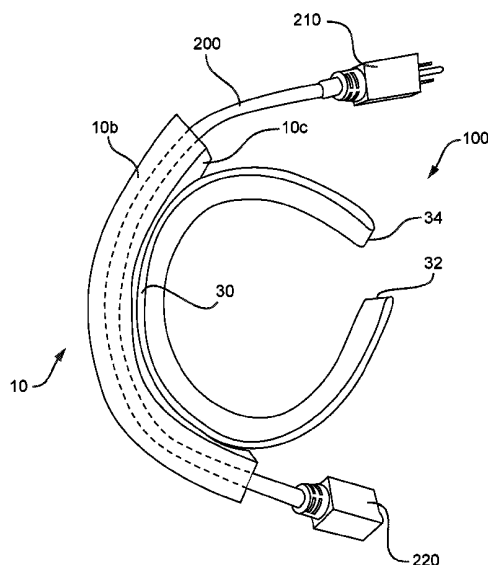

(56)	References Cited				
	U.S. PATENT DOCUMENTS				
3,404,268	A *	10/1968	Fowler	.....	F21V 21/088 362/418
3,501,117	A *	3/1970	Soltysik	.....	F16L 3/221 24/339
3,809,799	A *	5/1974	Taylor	.....	H02G 3/263 174/72 A
3,848,361	A *	11/1974	Foster	.....	F16L 3/01 439/31
4,169,571	A *	10/1979	Duggan	.....	F16L 3/00 248/439
4,404,425	A *	9/1983	Rich	.....	H01B 7/0823 174/117 A
4,406,434	A *	9/1983	Schneckloth	.....	F16L 3/26 248/83
4,445,299	A *	5/1984	Lehikoinen	.....	H01R 35/02 439/31
4,643,505	A	2/1987	House		
4,719,316	A *	1/1988	Hoffman	.....	F16G 11/06 174/91
4,749,363	A	6/1988	Luska		
4,870,722	A *	10/1989	Shell, Jr.	.....	H02G 3/26 248/69
4,907,767	A *	3/1990	Corsi	.....	H02G 3/0437 174/101
5,046,464	A *	9/1991	Hisatomi	.....	F02P 7/021 123/169 PA
5,067,679	A *	11/1991	Courtney	.....	F16L 3/26 248/75
5,108,055	A *	4/1992	Kreinberg	.....	F16L 3/13 24/703.1
5,166,478	A *	11/1992	Sprouse	.....	H02G 15/04 439/135
5,215,280	A *	6/1993	Tigrett	.....	H02G 9/065 D8/356
5,267,367	A	12/1993	Wegmann, Jr.		
5,280,866	A *	1/1994	Ueki	.....	H02G 3/32 248/74.2
5,399,812	A *	3/1995	Woszczyna	.....	B60R 16/0215 174/99 R
5,399,814	A *	3/1995	Staber	.....	H02G 3/0456 174/136
5,463,189	A *	10/1995	Deneke	.....	H02G 3/26 24/336
5,626,316	A *	5/1997	Smigel	.....	H02G 3/32 248/68.1
5,739,470	A *	4/1998	Takeda	.....	H02G 3/0487 174/101
5,905,231	A *	5/1999	Houte	.....	H02G 3/0481 174/95
6,087,593	A *	7/2000	Skipworth	.....	H02G 11/00 174/136
6,268,566	B1 *	7/2001	Takiguchi	.....	B60R 16/0215 174/72 A
6,274,813	B1 *	8/2001	Houte	.....	H02G 15/1813 428/36.5
6,350,135	B1	2/2002	Acklin		
6,392,147	B1 *	5/2002	Hier	.....	B60R 16/0215 174/72 A
6,464,178	B1 *	10/2002	Kidd, III	.....	F16L 3/1218 248/51
7,189,100	B1 *	3/2007	Colbourne	.....	H01R 13/6392 439/367
7,595,450	B2	9/2009	Lubanski		
8,001,643	B1	8/2011	James		
8,353,719	B2	1/2013	Watts		
8,613,411	B1 *	12/2013	Mohns	.....	F16L 3/1226 248/68.1
D776,623	S	1/2017	Jenkins		
9,701,263	B2 *	7/2017	Hagi	.....	B60R 16/0215
9,887,529	B2	2/2018	Dew		
2002/0000499	A1 *	1/2002	Aoki	.....	B60R 16/0215 248/51
2003/0159846	A1 *	8/2003	Takahashi	.....	H02G 3/0608 174/68.3
2004/0097120	A1	5/2004	Limber		
2007/0209822	A1	9/2007	Kaady		
2008/0134477	A1 *	6/2008	Hart	.....	H02G 3/263 24/457
2013/0146324	A1	6/2013	Byrne		
2014/0190735	A1	7/2014	Nixon-Lane		
2016/0013590	A1	1/2016	Williams		
2016/0268728	A1	9/2016	Zantout		
2016/0336681	A1	11/2016	Tutela		
2017/0264090	A1 *	9/2017	Shah	.....	H02G 3/0481
2020/0312847	A1	10/2020	Stahlman		
2021/0012931	A1	1/2021	Enomoto		

\* cited by examiner

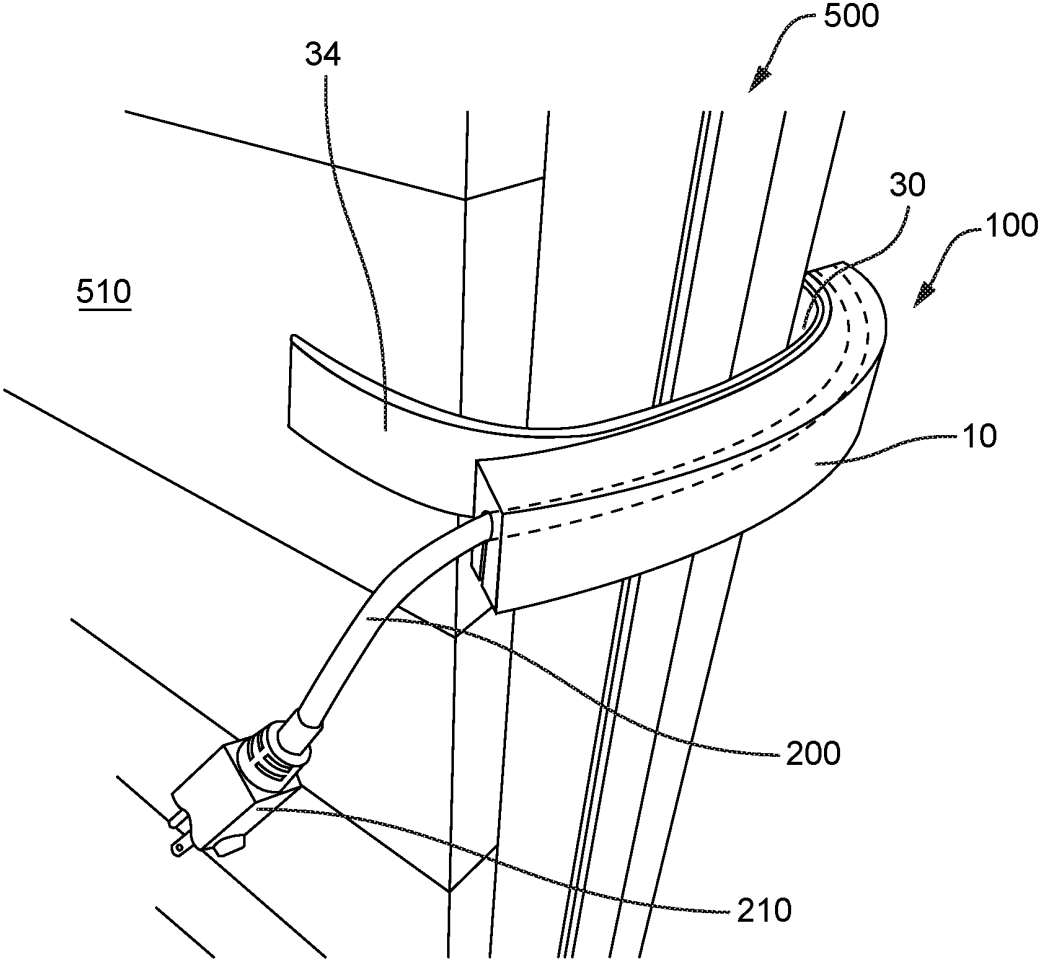

FIGURE 1

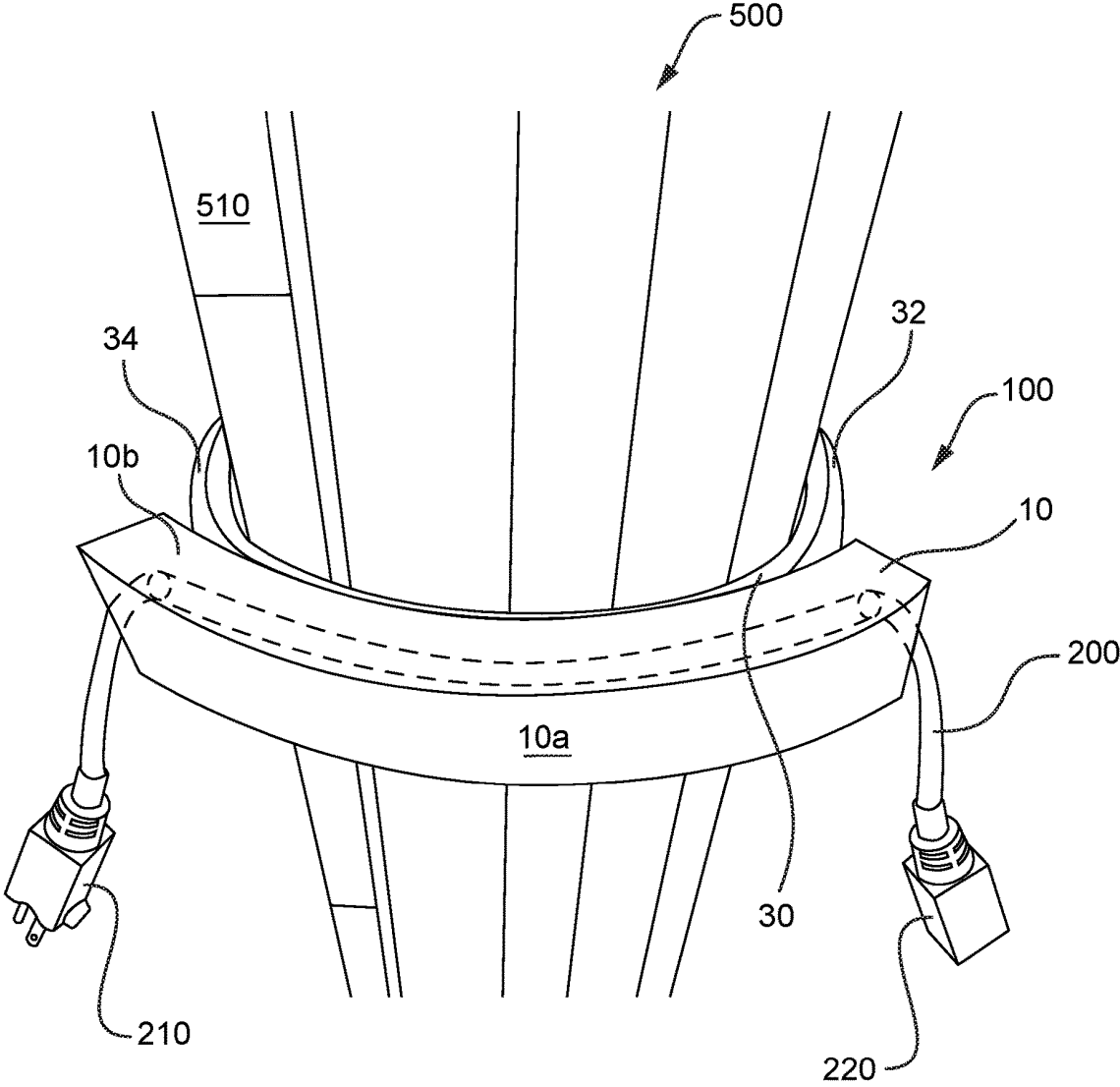

FIGURE 2

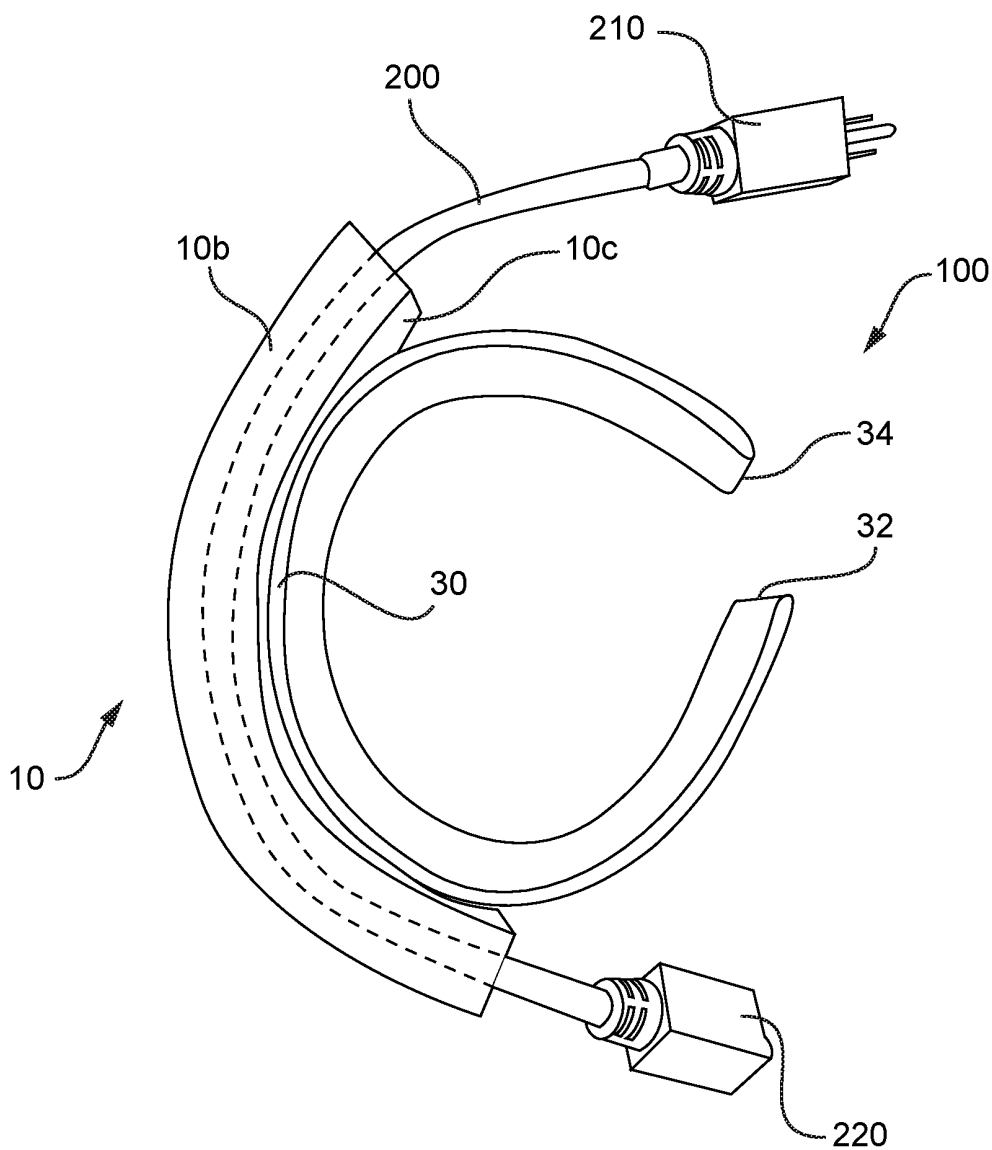

FIGURE 3

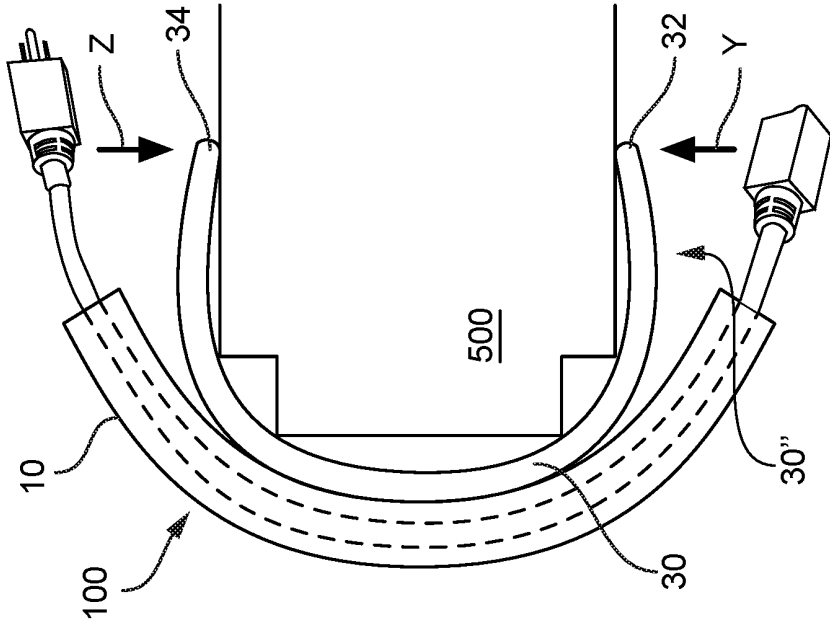

FIGURE 4B

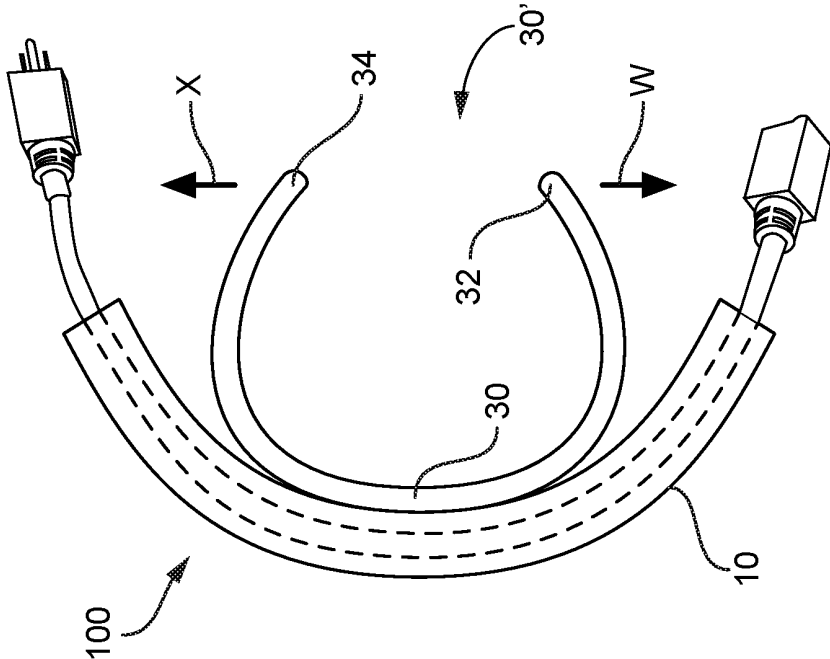

FIGURE 4A

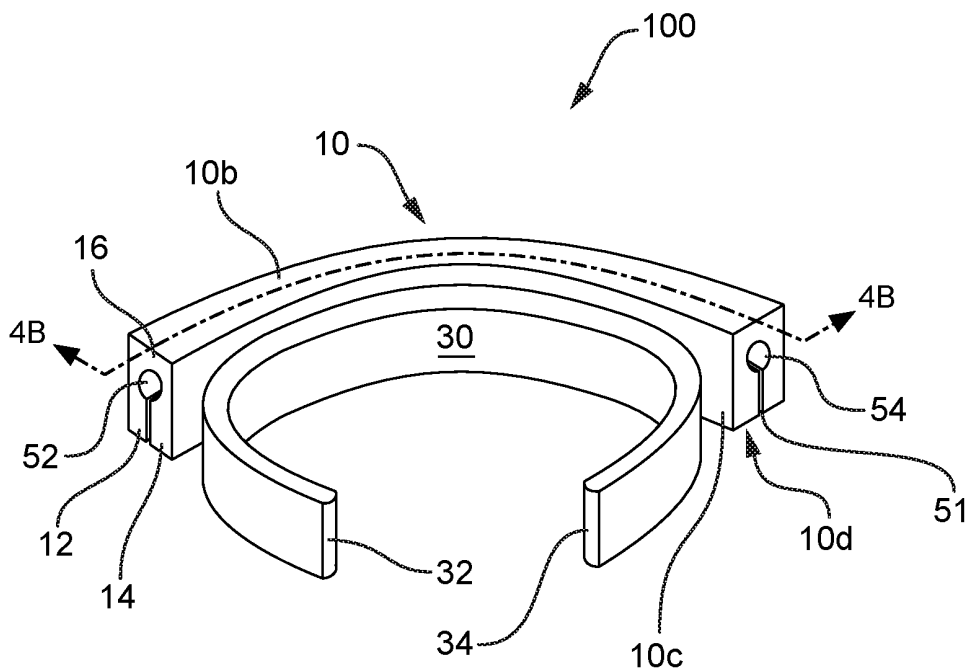

FIGURE 5A

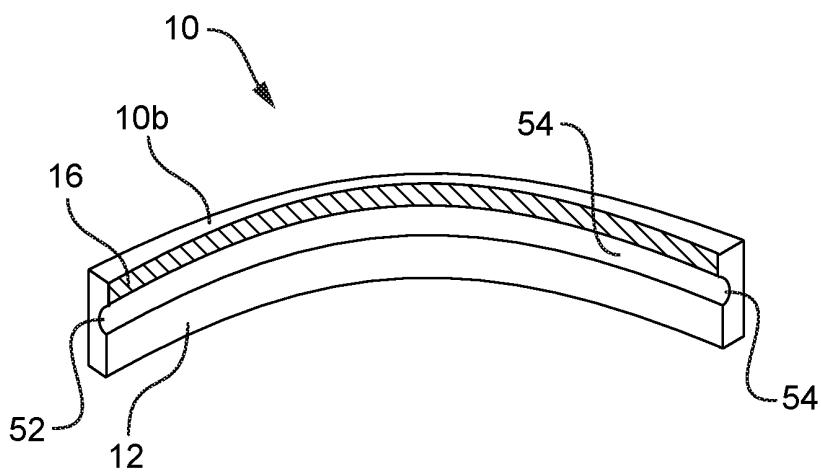

FIGURE 5B

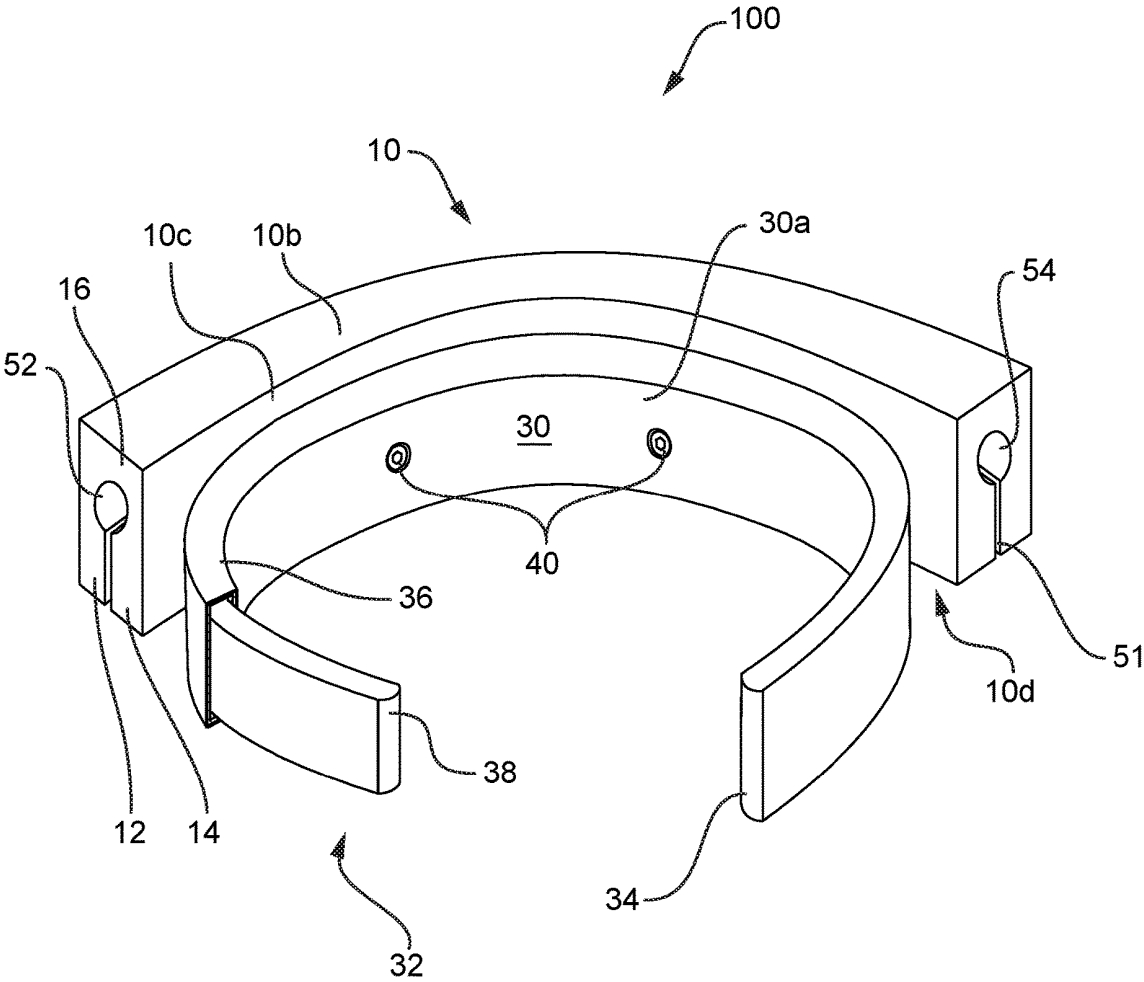

FIGURE 6



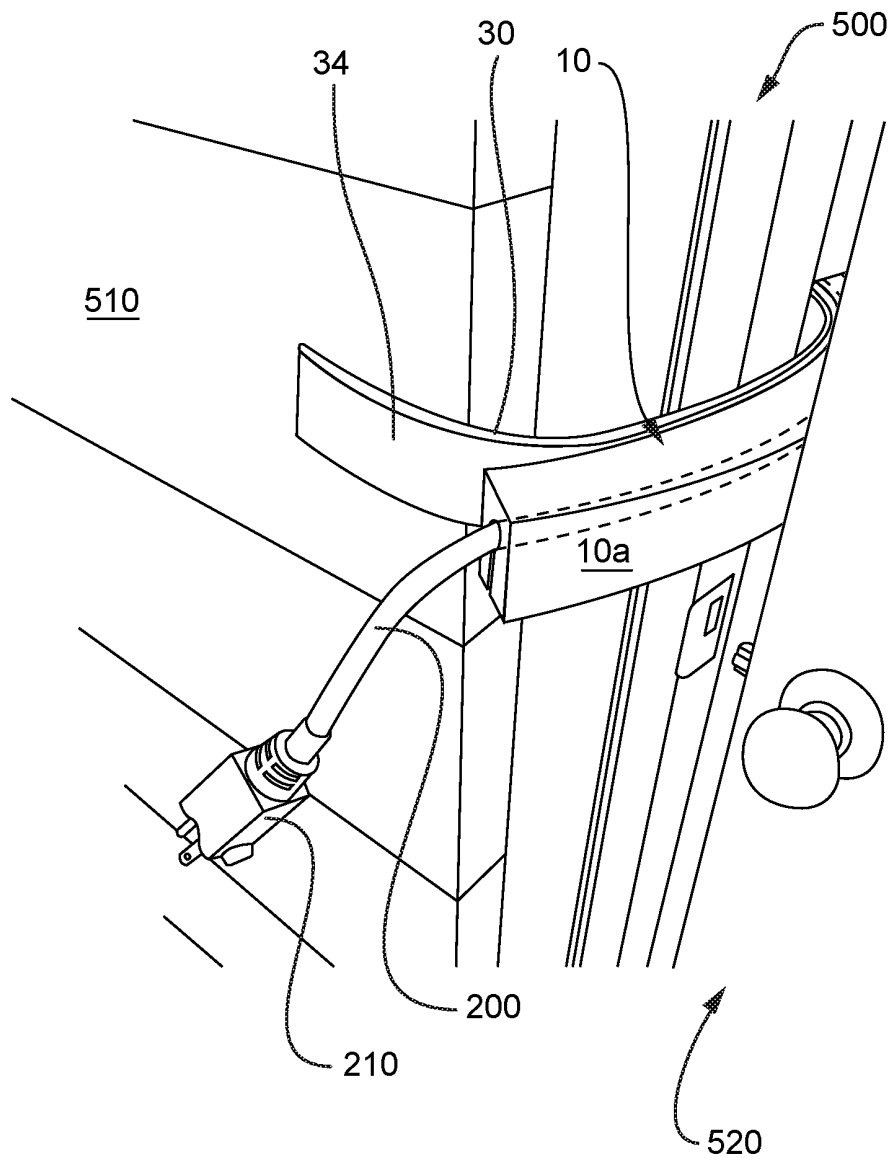

FIGURE 7

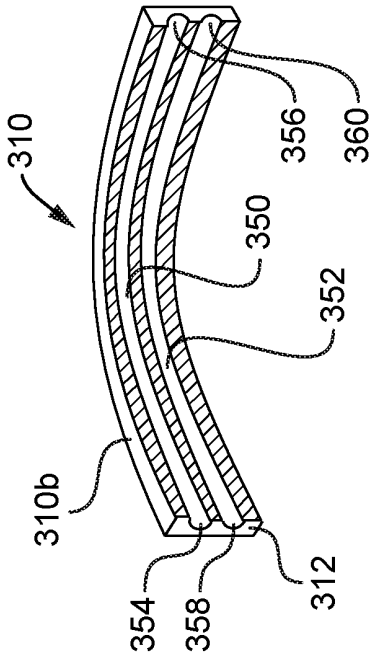

FIGURE 8B

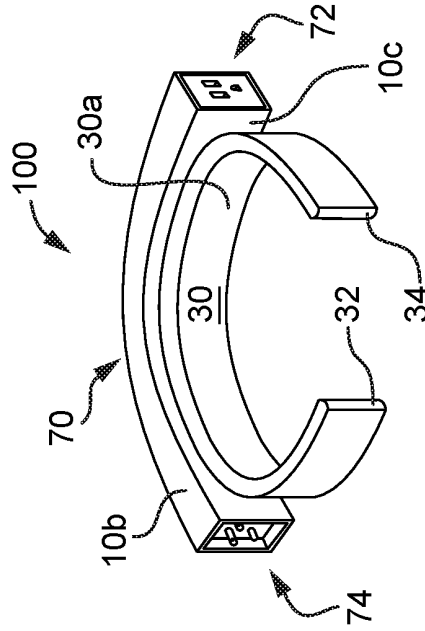

FIGURE 10

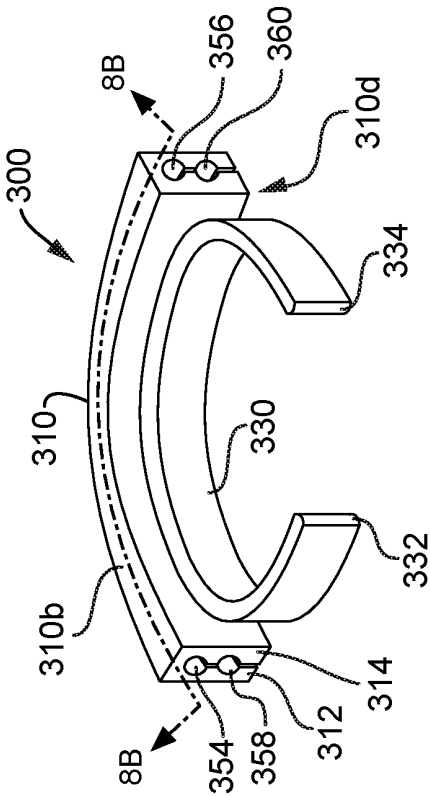

FIGURE 8A

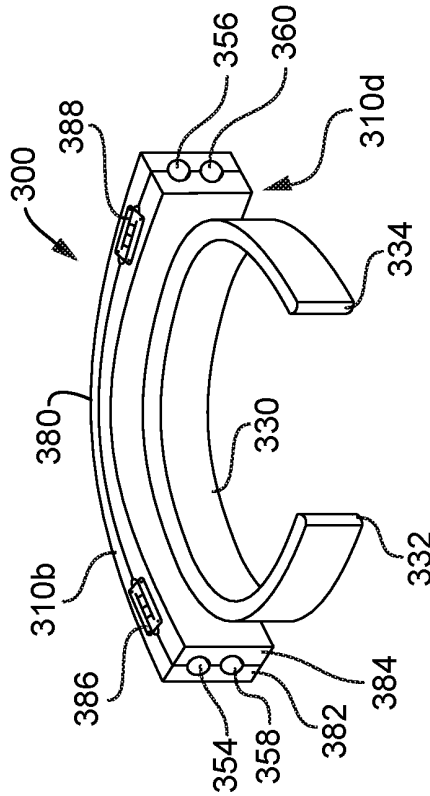

FIGURE 9

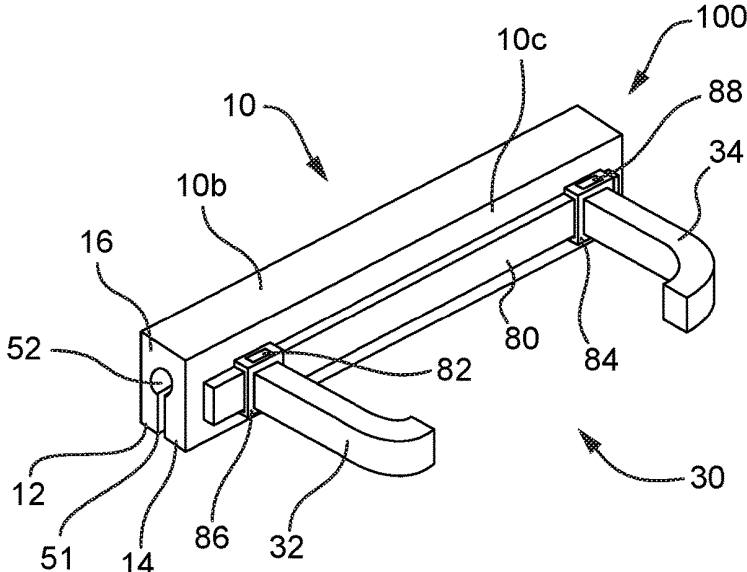

FIGURE 11

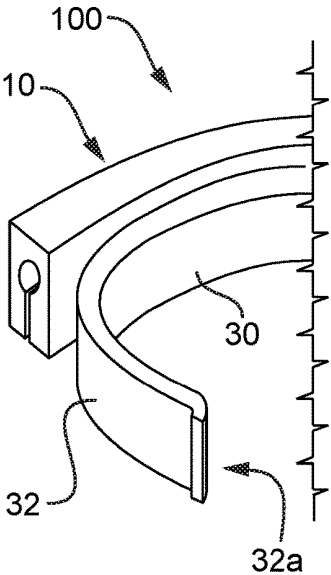

FIGURE 12

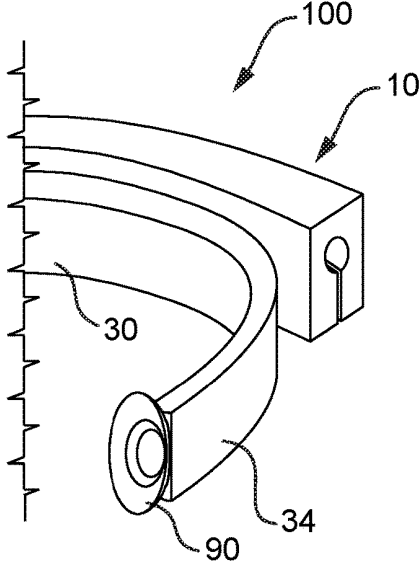

FIGURE 13

# 1

## CORD PROTECTOR

### FIELD

The instant disclosure generally relates to a cord, hose, and/or tube protector including a main body having a channel for receiving the cord, hose, and/or tube therein, as well as one or more clamping/gripping members that allow the main body to be detachably secured to an object, such as a door or window frame, thereby allowing the cord, hose, or tube disposed within the channel to be protected from damage that may result from an object such as a door or window that may be closed thereupon.

### BACKGROUND

The use of cord protective devices is known. U.S. Pat. No. 7,189,100 describes a cord protector including a housing having an access door for opening and closing the housing to secure and pass a cord therethrough. Similarly, U.S. Pat. No. 4,643,505 describes a cord protector having a housing including an access door, having a shape adapted for holding a pair of mated plugs, and securing members for holding the cords. Another type of cord protector is described in U.S. Pat. No. 3,183,302, which describes a device having a cylindrical housing including an access door and securing members for holding a plug therein. Another cord protector including an access door is described in U.S. Pat. No. 4,749,363 and describes a device that is configured for holding an extension plug having three positions thereon for receiving three male plugs.

While the above-described devices are suitable for their intended purposes, for example, preventing exposure of a male/female electrical cord connection from elements such as water, in the case of building construction site wherein many different tradesmen may be present along with their associated equipment, the likelihood of damage to electrical cords is significant, particularly when electrical cords may be placed on the ground where they can be exposed to foot traffic, liquids, and/or heavy equipment that can cause damage to the electrical cords. In addition to the damage that may occur when an electrical cord is placed on the ground at a construction site, the placement of electrical cords on the ground can also present a tripping hazard to personnel in the workplace. Hence, it is often desirable to secure such types of electrical cords at a height. In addition to the above, there are various federal, e.g., OSHA, state and local safety regulations that must be complied with, which often require that workers be shielded from the accidental exposure to electrical wires, connectors, and components in the workplace, that electrical cords be placed so as to avoid being damaged, placed so as to avoid being exposed to conductive materials, e.g., water and construction fluids, and/or placed or hung without the use of staples, nails or wires that may damage their insulative sheaths. Additionally, when an electrical cord must be passed from one room to another room, it typically must pass through an opening such as a door or window. Hence, damage to an electrical cord can occur when a door or window is shut and pinched between the door/door frame or window/window frame. Additionally, when electrical cords are passed through openings such as doors and windows so to avoid presenting tripping hazards, they are often secured using assemblies such as hooks that are secured to ceilings, walls and door or window frames using nails or screws that cause damage to the ceilings, walls, or door and window frames.

# 2

What is needed then, is a readily detachable cord protector that allows an electrical cord, a hose, or a tube to be safely passed through a door or window frame at a height, which cord protector does not cause damage to ceilings, walls or door or window frames, and which reduces the likelihood that the electrical cord, hose, or tube passed therethrough will be exposed to damage.

### SUMMARY

At the outset it should be understood that while the following disclosure, figures, and/or claims, etc. describe subject matter including one or more aspects described as either alone or in combination with one or more other aspects, the subject matter of the instant disclosure is not intended to be so limited. That is, the instant disclosure, figures, and claims are intended to encompass the various aspects described herein, either alone or in one or more combinations with one another. For example, while the instant disclosure may describe and illustrate a first aspect, a second aspect, and a third aspect in a manner such that the first aspect is only specifically described and illustrated relative to the second aspect, or the second aspect is only described and illustrated relative to the third aspect, the instant disclosure and illustrations are not intended to be so limiting and may encompass the first aspect alone, the second aspect alone, the third aspect alone, or one or more combinations of the first, second, and/or third aspects, e.g., the first aspect and the second aspect, the first aspect and the third aspect, the second and third aspect, or the first, second and third aspects.

The instant disclosure is generally directed to a cord protector that is detachably securable to an object. The cord protector generally includes a main body having at least one channel disposed therein that extends along a portion of a longitudinal length of the main body, which at least one channel is capable of receiving and securing a cord, hose, or tube therein. The cord protector further includes a clamping/gripping mechanism formed of a pair of oppositely disposed clamping/gripping arms that extend from opposite sides of the main body, which are inherently biased toward one another such that the clamping/gripping arms maintain a substantially closed position at rest. The cord protector is capable of being detachably secured to the object by opening the clamping/gripping arms against the inherent bias and allowing the clamping/gripping arms to return toward the resting position such that they may close and clamp upon the object.

In some aspects, the clamping/gripping arms are elastically deformable such that they are capable of being opened relative to one another against their inherent bias to maintain an active state, and closed relative to one another to return toward their original resting position.

In some aspects, at least one of the clamping/gripping arms include a portion thereof that is plastically deformable such that the portion may be bent or formed and repositioned.

In some aspects, the main body comprises a resilient composition formed of, for example, rubber or like material.

In some aspects, at least one of the clamping/gripping arms include an outer sheath portion and an inner core portion. In some aspects, the outer sheath comprises a resilient composition formed of, for example, rubber or like material, and the inner core portion includes an elastically deformable portion and a plastically deformable portion, the elastically deformable portion being disposed proximate a central region of the clamping/gripping mechanism and the

plastically deformable portion being disposed proximate the terminal end regions of each of the clamping/gripping arms. In some aspects, the inner core portion comprises a metal that may be bent or formed and reformed.

In some aspects, the at least one channel extends along the longitudinal length of the main body. In some aspects, the main body includes an outer separated region, an inner separated region, and a bridge portion, the outer separated region and the inner separated region are connected to one another via the bridge portion and are separated from one another by a groove portion in connection with the at least one channel. In some aspects, the bridge portion serves as a hinge allowing the outer separated region and the inner separated region to be separated and opened relative to one another thereby allowing access to the at least one channel and then closed upon one another. In some aspects, the outer separated region and the inner separated region are inherently biased and or may be biased toward one another to maintain a closed position.

In some aspects, the main body includes a plurality of channels extending along a portion of a longitudinal length of the main body and each of the plurality of channels is capable of receiving and securing a cord, line, or tube therein.

In some aspects, the main body includes a cord, line or tube that is integral with the main body and includes a first terminal end having a female connector end and a second terminal end having a male connector.

In some aspects, the main body comprises an outer separated region, an inner separated region, and a hinge, and the hinge connects the outer separated region and the inner separated region to one another such that the outer separated region and the inner separated region are openable and closeable relative to one another.

These and other aspects, features, and advantages of the present disclosure will be readily appreciable from the following description in view the accompanying drawings and claims.

### BRIEF DESCRIPTION OF THE DRAWINGS

The nature and mode of operation of an invention in accordance with the instant disclosure will now be more fully described in the following detailed description of the invention taken with the accompanying drawing figures, in which:

FIG. 1 is a leftward-side perspective view of a cord protector according to the instant disclosure detachably secured attached to a doorframe;

FIG. 2 is a front perspective view of a cord protector according to the instant disclosure detachably secured attached to a doorframe;

FIG. 3 is a top plan view of a cord protector according to the instant disclosure;

FIGS. 4A and 4B are top plan views of a cord protector according to the instant disclosure wherein the clamping gripping mechanism is disposed in respective closed/resting and open/active positions;

FIG. 5A is a rear perspective view of a cord protector according to the instant disclosure without an extension cord inserted in the main body;

FIG. 5B is a rear perspective sectional view of a cord protector according to the instant disclosure taken generally along line 5B-5B of FIG. 5A;

FIG. 6 is a rear perspective view of a cord protector according to the instant disclosure without an extension cord

inserted in the main body and showing a portion of the outer cover of the clamping/gripping mechanism removed;

FIG. 7 is a right-side view of a cord protector according to the instant disclosure detachably secured to a doorframe at a height and showing that the cord disposed therein is protected from damage from as a result of the door being closed upon the main body;

FIG. 8A is a rear perspective view of a cord protector according to the instant disclosure including a plurality of channels;

FIG. 8B is a rear perspective sectional view the main body of a cord protector according to the instant disclosure including a plurality of channels taken generally along line 8B-8B of FIG. 8A;

FIG. 9 is a rear perspective view of a cord protector according to the instant disclosure including a plurality of channels, as well as a hinge mechanism;

FIG. 10 is a rear perspective view of a cord protector according to the instant disclosure including an integral cord and associated connectors, e.g., male and female connectors;

FIG. 11 is a front perspective view of a cord protector according to the instant disclosure including an adjustable clamping mechanism; and,

FIGS. 12 and 13 are partial front perspective views of a cord protector according to the instant disclosure showing a terminal end of a first arm including a bendable/reformable end, and a terminal end of a second arm including an additional frictional surface in the form of a rubber pad suction cup.

### DETAILED DESCRIPTION

At the outset, it should be appreciated that like drawing numbers on different drawing views identify identical, or functionally similar, structural elements. It is to be understood that the claims are not limited to the specifically disclosed and illustrated aspects.

Furthermore, it is understood that this disclosure is not limited to the particular methodologies, materials and modifications described and as such may, of course, vary. It is also understood that the terminology used herein is for the purpose of describing particular aspects only and is not intended to limit the scope of the disclosure or claims.

Unless defined otherwise, all technical and scientific terms used herein have the same meaning as commonly understood to one of ordinary skill in the art to which this disclosure belongs. Although any methods, devices or materials similar or equivalent to those described herein can be used in the practice the example aspects.

It should be understood that use of "or" in the present application is with respect to a "non-exclusive" arrangement, unless stated otherwise. For example, when saying that "item x is A or B," it is understood that this can mean one of the following: (1) item x is only one or the other of A and B; (2) item x is both A and B. Alternately stated, the word "or" is not used to define an "exclusive or" arrangement. For example, an "exclusive or" arrangement for the statement "item x is A or B" would require that x can be only one of A and B. Moreover, as used herein, the phrases "comprises at least one of" and "comprising at least one of" in combination with a system or element is intended to mean that the system or element includes one or more of the elements listed after the phrase. For example, a device comprising at least one of: a first element; a second element; and, a third element, is intended to be construed as any one of the following structural arrangements: a device comprising a first element; a device comprising a second element; a

device comprising a third element; a device comprising a first element and a second element; a device comprising a first element and a third element; a device comprising a first element, a second element and a third element; or, a device comprising a second element and a third element. A similar interpretation is intended when the phrase “used in at least one of:” is used herein. Furthermore, as used herein, “and/or” is intended to mean a grammatical conjunction used to indicate that one or more of the elements or conditions recited may be included or occur. For example, a device comprising a first element, a second element and/or a third element, is intended to be construed as any one of the following structural arrangements: a device comprising a first element; a device comprising a second element; a device comprising a third element; a device comprising a first element and a second element; a device comprising a first element and a third element; a device comprising a first element, a second element and a third element; or, a device comprising a second element and a third element.

It should be appreciated that the term “substantially” and “generally” are synonymous with terms such as “nearly,” “very nearly,” “about,” “approximately,” “around,” “bordering on,” “close to,” “essentially,” “in the neighborhood of” “in the vicinity of” etc., and such terms may be used interchangeably as appearing in the specification and claims. It should be appreciated that the term “proximate” is synonymous with terms such as “nearby,” “close,” “adjacent,” “neighboring,” “immediate,” “adjoining,” etc., and such terms may be used interchangeably as appearing in the specification and claims. The term “approximately” is intended to mean values within ten percent of the specified value.

While the following terms are not to be specifically limited, “non-rotatably connected” elements, is intended to refer to that the elements are connected so that whenever one of the elements rotate, all the elements rotate; and relative rotation between the elements is not possible. Radial and/or axial movement of non-rotatably connected elements with respect to each other is possible, but not required. Additionally, “plastic deformation” is intended to refer to, for example, instances wherein when a sufficient load is applied to a material to form it into a desired shape and such force released, the material is formed into the desired shape and the desired shape maintained until a further sufficient force may be applied so as to reform the material. In other words, a material subject to plastic deformation may be subject to a sufficient force so to bend or form such material to maintain a first shape, and then may be subject to a subsequent sufficient force to bend or reform such material to return it so as to maintain its original shape, or to maintain a further shape. “Elastic deformation” is intended to refer to instances wherein when a sufficient load is applied to a material such material undergoes a temporary shape change while subject to such force but is restored to its original shape upon release of such force. “Resilient” can refer to the ability of a material to return to its original form and/or have force absorbing/rebounding qualities. Hence, a material can be resilient in the sense that upon application of a force it rebounds entirely to return to its original form, e.g., some rubbers, non-resilient in that it has no rebound and does not return to its original form, e.g., some hard plastics and metals, or semi-resilient in that it only partially rebounds and only partially returns to its original form, e.g., some plastics, rubbers and foams, etc.

Also, the descriptors “outer”, “inner”, “upper”, “lower”, “top”, “bottom”, “right”, “left”, and their derivatives in the description herebelow refer to the perspective of one facing

the inventive subject matter as shown in, for example, FIG. 1. Additionally, it should be understood that the use of such descriptors is for orientation purposes in order to describe the inventive subject matter and, unless otherwise specified, is not intended to specifically define one or more sides, or surfaces, as such.

It should be appreciated that while the instant disclosure primarily describes a “cord protector” used in association with an electrical cord, e.g., an electrical extension cord, the cord protector is not intended to be limited to receiving an electrical cord, but rather can be configured to receive a hose, a tube, or a line, or combinations thereof, e.g., an electrical cord and a pneumatic hose.

Adverting now to the figures, which depicts cord protector **100** detachably secured to door frame **500** via wall/surface(s) **510** by means of the inherent bias provided by clamping/gripping mechanism **30**. As may be appreciated from the figures, cord protector generally comprises main body **10**, first arm **32**, and second arm **34**.

#### Main Body

Main body **10** is generally configured to comprise a longitudinal length capable of spanning the width/depth of door frame **500**, or a window frame and in some aspects is formed from a resilient or semi-resilient material such as rubber, plastics, foams, and/or combinations thereof. In some aspects, the main body can also include a protective sheath of which can be woven and comprise one or more of a fabric, rubber of plastic, or metal, which allow the main body to be adjusted, bend, or expand/contract. In some aspects, the longitudinal length of main body **10** is such that its terminal ends extend beyond door frame **500** or a window frame and/or wrap about door frame **500** or window frame. In some aspects, the terminal ends of main body **10** are such that they are configured to overlap wall surface(s) **510** on each side of a wall or window frame—this configuration can assist in preventing cord protector **100** from being inadvertently dislodged from a door or window frame upon application of a force such as the closure of a door or window. In sum, by allowing the terminal ends of main body to extend past the door or window frame, a door or window is more apt to close upon and pinch the terminal ends between a door and a door frame, for example, rather than dislodge the cord protector from its secured position. As shown in the attached figures, while main body **10** is illustrated as generally having a fixed longitudinal length extending past the width/depth of door frame **500**, as shown in FIG. **11**, the main body **10** can be configured to include an adjustable assembly that allows the first arm **32** and the second arm **34** to be slidably adjusted relative to one another so as to allow the cord protector to be adjusted as may be needed in order fit walls/surfaces that may be wide or narrow. More specifically, as shown in FIG. **11**, for example, main body **10** can be configured to include rail assembly **80** capable of slidably receiving slidably attachment **82** that slidably secures first arm **32** and slidably attachment **84** that slidably secures second arm **34**. As may be appreciated, slidably attachments **82** and **84** can include securing/releasing mechanisms **86** and **88**, which are configured for unlocking the slidably attachments so as to allow the first arm and the second arm to be slidably adjusted relative to one another along rail **80**, and then locked to maintain the desired position of the first arm relative and the second arm. Securing/releasing mechanisms **82** and **84** may comprise suitable means for allowing the first arm and the second arms to be unlocked, slidably adjusted and then locked in a suitable position. Such suitable means can include, but are not limited to pin/detent assemblies, ratcheting-type assemblies, threaded/worm-type assemblies,

lever and vise-type assemblies, etc. In addition to the above, main body **10** can be configured to be adjustable by, for example, having an accordion-like structure, which allows the main body to be adjustable expanded and contracted to fit a specific application, and also allow a single cord protector **100** to satisfy several different applications.

As shown more clearly in FIGS. 1-5B, main body **10** generally includes outer surface **10a**, inner surface **10c**, upper surface **10b** and lower surface **10d**, as well as outer separated portion **12**, inner separated portion **14**, bridge portion **16**, channel **50**, and groove **51**. As may be appreciated, outer surface **10a**, inner surface **10c**, upper surface **10b** and lower surface **10d** generally define the exterior surface of main body **10**, which is shown in the figures in the form of a rectangularly-shaped structure. Other shaped structures are contemplated and the exterior surfaces of the main body can be configured, for example, to form a cylindrically shaped structure. As shown in FIGS. 5A and 5B, outer separated portion **12** and inner separated portion **14** are partially separated from one another by channel **50** and groove/slit **51** but remain connected to one another via bridge portion **16**. In the figures, channel **50**, and groove/slit **51** in communication therewith, is shown as extending along the length of main body **10** from first channel opening **52** to second channel **54** opening, but such is not necessarily required and the channel and groove may extend only along a portion of the main body, i.e., first and channel second openings **52** and **54** may be disposed proximate the terminal ends of the main body, but not necessarily at the terminal ends of the main body.

Outer separated portion **12**, inner separated portion **14**, bridge portion **16**, channel **50**, and groove **51** are provided for allowing an access point and void into which a length of a cord, hose, tube or line may be inserted and then safely retained for purposes of protecting such cord, hose or line from damage. Accordingly, as shown in FIGS. 1-5A, outer separated portion **12**, inner separated portion **14**, and bridge portion **16** are configured to generally maintain a closed configuration at rest such that the outer separated portion **12** and inner separated portion **14** corresponding to groove/slit **51** contact one another to retain a cord, hose, tube, or line within channel **50**. Bridge portion **16** is generally provided for connecting the outer separated portion **12** and inner separated portion **14** of main body to one another, but also serves as a hinge mechanism to allow the outer separated portion **12** and inner separated portion **14** to be separated along groove/slit **51** in order to insert a cord, hose, tube, or line into channel **50**. As may be appreciated, because the main body can be fabricated from a resilient or semi-resilient material such as rubber, plastic, foam, etc. and/or combinations thereof, upon applying a force to open groove/slit **51** in order to insert a cord, hose, tube, or line into channel **50**, the release of such force causes main body **10** to return to its original resting shape so as to secure and retain the cord, hose, tube, or line within channel **50**.

#### Clamping/Gripping Mechanism

Clamping/Gripping Mechanism **30** is generally configured for detachably securing main body **10**, to which it is fastened, to a surface or structure such as door frame **500**, or a window frame. In some aspects, clamping gripping mechanism **30** is formed from a metal band having a first arm **32**, a second arm **34**, a central portion disposed between first arm and second arm, and an outer sheath **36**, which can extend along one or more lengths thereof and be formed of a rubber, plastic woven fabric so as to prevent or minimize damage to a surface to which the cord protector is detachably secured, e.g., door frame **500**. As may be appreciated

from the figures, main body **10** can be fastened to the central region of the clamping/gripping mechanism **30** by means of appropriate fasteners **40**, e.g., nuts and bolts, rivets, screws, etc. and can be of a fixed longitudinal length between the terminal ends of first arm **32** and second arm **34** of sufficient length such that its terminal ends extend beyond door frame **500** or a window frame and/or wrap about door frame **500** or window frame. In some aspects, the terminal ends of clamping/gripping mechanism **30** are such that they are configured to overlap wall surface(s) **510** on each side of a wall or window frame—this configuration can assist in preventing cord protector **100** from being inadvertently dislodged from a door or window frame upon application of a force such as the closure of a door or window. In sum, by allowing the terminal ends of the clamping/gripping mechanism **30** to extend past the door or window frame so as to grip wall surface **510**, a door or window is more apt to close upon and pinch the terminal ends between the door and a door frame, for example, rather than dislodge the cord protector from its secured position. As shown in the attached figures, while clamping/gripping mechanism **30** is illustrated as generally having a fixed longitudinal length extending past the width/depth of door frame **500**, as shown in FIG. 11, the main body **10** can be configured to include an adjustable assembly that allows the first arm **32** and the second arm **34** to be slidably adjusted relative to one another so as to allow the cord protector to be adjusted as may be needed in order to fit walls/surfaces that may be wide or narrow. More specifically, as shown in FIG. 11, for example, main body **10** can be configured to include rail assembly **80** capable of slidably receiving slidable attachment **82** that slidably secures first arm **32** and slidable attachment **84** that slidably secures second arm **34**. As may be appreciated, slidable attachments **82** and **84** can include securing/releasing mechanisms **86** and **88**, which are configured for unlocking the slidable attachments so as to allow the first arm and the second arm to be slidably adjusted relative to one another along rail **80**, and then locked to maintain the desired position of the first arm relative and the second arm. Securing/releasing mechanisms **82** and **84** may comprise suitable means for allowing the first arm and the second arms to be unlocked, slidably adjusted and then locked in a suitable position. Such suitable means can include, but are not limited to pin/detent assemblies, ratcheting-type assemblies, threaded/worm-type assemblies, lever and vise-type assemblies, etc. Additionally, the clamping/gripping mechanism can be configured to be adjustable by, for example, having portions of the first arm **32** and the second arm **34** slidably received by the other, which allows the clamping/gripping mechanism to be adjustable expanded or contracted to fit the specific application, and also allow a single cord protector **100** to satisfy several different applications.

As may be appreciated from the figures, clamping/gripping mechanism **30** generally comprises a banded structure that forms a C-shape, of which portions thereof are capable of exhibiting elastic deformation. That is, as shown in FIGS. 4A and 4B, first arm **32** and second arm **34** are configured to maintain a resting/closed position **30'** having the C-shape as shown in FIG. 4A. However, when sufficient forces are applied upon the first arm **32** and the second arm **34** in the direction of arrows X and W in FIG. 4A, the clamping/gripping mechanism may be placed the open/active position **30''** for purposes of detachably securing the cord protector to a door or window frame or other surface. As shown in FIG. 4B, when the first arm **32** and the second arm **34** of the clamping/gripping mechanism **30** are opened and each secured about door frame **500**, when the applied force is then

released, the first arm **32** and second arm **34** attempt to return to the resting/closed position **30'** of FIG. 4A, but rather assert forces Y and Z against wall surface **510**, which serves to secure the cord protector to wall **510**. As shown in FIG. 13, regions proximate the inner surfaces of the terminal ends of first arm **32** and second arm **34** can be configured to include friction surfaces **90**, e.g., rubber pads, suction cups, etc., that can provide additional friction tending to increase the ability of the clamping/gripping mechanism **30** to remain secured to a surface. In addition to the above, while the clamping/gripping mechanism **30** can comprise inner core **38** formed from a metal band having first arm **32**, second arm **34**, and a central portion disposed between the first arm and the second arm, and has been described as being elastically deformable such that the clamping/gripping mechanism returns to its original shape upon the release of an applied force, as shown in FIG. 12 portions of the first arm **32** and the second arm **34** proximate the terminal ends thereof can be configured to comprise one or more plastically deformable portions **32a** that allow such portions to be bent and formed and/or reformed to a desired shape. In such cases, such portions **32a**, owing to their plastic deformative ability, can then maintain such bent/reformed shape so as to, for example, be formed into a shape that is complementary to a surface to which the clamping/gripping mechanism may be secured. The above can be provided, for example, via an inner core **38** of metal having a thickness that is greater proximate the central portion of the clamping/gripping mechanism, and thinner proximate the terminal ends of the first arm and the second arm, which allow such terminal portions to be formed and reformed into a desired shape.

In accordance with the above, a cord, such as electrical extension cord **200** having male and female connectors **210** and **220**, respectively, or a hose, tube or line can be secured within cord protector **100** and secured about door frame **500** and to wall surface **510** by opening the clamping/gripping mechanism **30**, placing the clamping/gripping mechanism about the door frame, and releasing the first arm **32** and second arm **34** to allow them to assert a force upon wall surface(s) **510**.

#### Alternative/Additional Configurations

Referring now to FIGS. 8A-10, the above-described cord protector **100** can be configured in one or more alternate manners without departing from the spirit and scope of the inventive subject matter. For example, as shown in FIGS. 8A-8B, a cord protector in accordance with the instant disclosure can be configured similar to the previously described cord protector **100**, but instead comprise a plurality of channels for passing multiple cords, hoses, tubes, lines, or combinations thereof therethrough. Similarly, as shown in FIG. 9, a cord protector in accordance with the instant disclosure can be configured to comprise inner and outer separated portions wholly separate from one another but connected to one another via a separate and distinct hinge, which allow the inner and outer separated portions to be opened and closed via the hinge. While not shown, a cord protector including a separate and distinct hinge can also include a tab/locking mechanism (not shown) for ensuring that the inner and outer separated portions can remain closed and secured relative to one another once a cord, hose, tube or line has been secured therein. Also, as shown in FIG. 10, cord protector **70** in accordance with the instant disclosure can be configured to comprise a cord, hose, tube or line that is integral with the main body **10**. As shown by way of example in FIG. 10, the electrical cord main body **10** can be configured to include male and female connectors **74**, **72**, respectively, integrally formed into the main body at respec-

tive terminal ends thereof the main body, with the electrical cord disposed therebetween within a channel of the main body. Finally, while the clamping/gripping mechanism **30** has been described and illustrated herein as comprising fixed or adjustable metal band having a first arm **32**, a second arm **34**, a central portion disposed between first arm **32** and second arm **34**, which allows the cord protector to be secured to a surface using the bias asserted by the first arm and the second arm, the clamping/gripping mechanism could comprise an alternative clamping/gripping mechanism such as an adjustable vise clamp allowing the gripping arms to be manually opened and closed via a lever or like structure.

Thus, it is seen that the objects of the invention are efficiently obtained, although modifications and changes to the invention may be readily imagined by those having ordinary skill in the art, and these changes and modifications are intended to be within the scope of the claims.

#### REFERENCE NUMBERS

**10** Main Body  
**10a** Outer Surface  
**10b** Upper Surface  
**10c** Inner Surface  
**10d** Lower Surface  
**12** Outer Separated Portion  
**14** Inner Separated Portion  
**16** Bridge Portion  
**30** Clamping/Gripping Mechanism  
**30'** Resting Closed Position  
**30''** Active Open Position  
**32** First Arm  
**32a** Bendable/Reformable Portion  
**34** Second Arm  
**36** Outer Sheath  
**38** Inner Core  
**40** Fastening Assembly  
**50** Channel  
**51** Groove/Slit  
**52** First Channel Opening  
**54** Second Channel Opening  
**60** Hinge  
**70** Main Body w/Integrated Cord and Connectors  
**72** Female Connector (Receptacle)  
**74** Male Connector (Plug)  
**80** Rail  
**82** Slidable Attachment  
**84** Slidable Attachment  
**86** Securing/Releasing Mechanism  
**88** Securing/Releasing Mechanism  
**90** Friction Surface  
**100** Cord Protector  
**200** Cord  
**210** Male Connector  
**220** Female Connector  
**500** Door frame  
**510** Wall  
**520** Door  
W Direction  
X Direction  
Y Direction  
Z Direction

What is claimed is:

1. A cord protector detachably securable to an object, comprising:



a main body, the main body having at least one channel disposed therein, the at least one channel extending along a portion of a longitudinal length of the main body, the at least one channel capable of receiving and securing a cord, line, or tube therein;

a clamping/gripping mechanism comprising a pair of oppositely disposed clamping/gripping arms that extend from opposite sides of the main body, the clamping/gripping arms are biased toward one another such that the clamping/gripping arms maintain a substantially closed position at rest;

wherein, the cord protector is capable of being detachably secured to the object by opening the clamping/gripping arms and allowing the clamping/gripping arms to close and clamp upon the object;

wherein at least one of the clamping/gripping arms include an outer sheath portion and an inner core portion;

wherein the outer sheath comprises a resilient composition and the inner core portion includes an elastically deformable portion and a plastically deformable portion, the elastically deformable portion being disposed the at a central region of the clamping/gripping mechanism and the plastically deformable portion being disposed proximate the terminal end regions of each of the clamping/gripping arms; and

wherein the inner core portion comprises a metal.

2. The cord protector of claim 1, wherein a cord, line or tube is secured within the at least one channel, and the cord, line or tube includes at least one female connector end, at least one male connector end, or a combination of a female connector end and a male connector end.

3. A cord protector detachably securable to an object, comprising:

a main body, the main body having at least one channel disposed therein, the at least one channel extending along a portion of a longitudinal length of the main body, the at least one channel capable of receiving and securing a cord, line, or tube therein;

a clamping/gripping mechanism comprising a pair of oppositely disposed clamping/gripping arms that extend from opposite sides of the main body, the clamping/gripping arms are biased toward one another such that the clamping/gripping arms maintain a substantially closed position at rest;

wherein, the cord protector is capable of being detachably secured to the object by opening the clamping/gripping arms and allowing the clamping/gripping arms to close and clamp upon the object;

wherein, the main body includes an outer separated portion, an inner separated portion, and a bridge portion, the outer separated portion and the inner separated portion connected to one another via a bridge portion and separated from one another by a groove portion connected to the at least one channel.

4. The cord protector of claim 3, wherein the at least one channel extends along the longitudinal length of the main body.

5. The cord protector of claim 3, wherein the main body includes a plurality of channels extending along a portion of a longitudinal length of the main body, each of the plurality of channels capable of receiving and securing a cord, line, or tube therein.

6. The cord protector of claim 3, wherein the clamping/gripping arms are elastically deformable such that they are capable of being opened relative to one another against their

bias to maintain an active state, and closed relative to one another to return to their original resting position.

7. The cord protector of claim 3, wherein at least one of the clamping/gripping arms include a portion thereof that is plastically deformable such that the portion may be formed and repositioned.

8. The cord protector of claim 3, wherein the main body comprises a resilient composition.

9. The cord protector of claim 3, wherein at least one of the clamping/gripping arms include an outer sheath portion and an inner core portion.

10. The cord protector of claim 9, wherein the outer sheath comprises a resilient composition and the inner core portion comprises a metal having an elastically deformable portion and a plastically deformable portion, the elastically deformable portion being disposed the at a central region of the clamping/gripping mechanism and the plastically deformable portion being disposed proximate the terminal end regions of each of the clamping/gripping arms.

11. The cord protector of claim 3, wherein a cord, line or tube is secured within the at least one channel, and the cord, line or tube includes at least one female connector end, at least one male connector end, or a combination of a female connector end and a male connector end.

12. A cord protector detachably securable to an object, comprising:

a main body, the main body having at least one channel disposed therein, the at least one channel extending along a portion of a longitudinal length of the main body, the at least one channel capable of receiving and securing a cord, line, or tube therein;

a clamping/gripping mechanism comprising a pair of oppositely disposed clamping/gripping arms that extend from opposite sides of the main body, the clamping/gripping arms biased toward each other such that the clamping/gripping arms maintain a substantially closed position at rest;

wherein, the cord protector is capable of being detachably secured to the object by opening the clamping/gripping arms and allowing the clamping/gripping arms to close upon the object;

wherein the main body comprises an outer separated portion, an inner separated portion, and a hinge, the hinge connecting the outer separated portion and the inner separated portion to one another such that the outer separated portion and the inner separated portion are openable and closeable relative to one another; and, wherein the cord, line, or tube is capable of being secured within the at least one channel by opening the outer and inner separated portions relative to one another, securing the cord, line, or tube therein, and closing the outer and inner separated portions upon one another.

13. The cord protector of claim 12, wherein the main body includes a plurality of channels extending along a portion of a longitudinal length of the main body, each of the plurality of channels capable of receiving and securing a cord, line, or tube therein.

14. The cord protector of claim 12, wherein the clamping/gripping arms are elastically deformable such that they are capable of being opened relative to one another against their bias to maintain an active state, and closed relative to one another to return to their original resting position.

15. The cord protector of claim 12, wherein at least one of the clamping/gripping arms include a portion thereof that is plastically deformable such that the portion may be formed and repositioned; wherein the main body comprises a resilient composition;

wherein at least one of the clamping/gripping arms include an outer sheath portion and an inner core portion; and

wherein, the outer sheath comprises a resilient composition and the inner core portion comprises a metal 5 having an elastically deformable portion and the plastically deformable portion, the elastically deformable portion being disposed the at a central region of the clamping/gripping mechanism and the plastically 10 deformable portion being disposed proximate the terminal end regions of each of the clamping/gripping arms.

16. The cord protector of claim 12, wherein a cord, line or tube is secured within the at least one channel, and the cord, line or tube includes at least one female connector end, at 15 least one male connector end, or a combination of a female connector end and a male connector end.

\* \* \* \* \*