



US011227467B2

(12) **United States Patent**  
**Emori**

(10) **Patent No.:** **US 11,227,467 B2**

(45) **Date of Patent:** **Jan. 18, 2022**

(54) **INFORMATION PROCESSING APPARATUS EXECUTABLE IN A USER SELECTABLE MEDIUM OF EXCHANGE**

(56) **References Cited**

U.S. PATENT DOCUMENTS

(71) Applicant: **Universal Entertainment Corporation**, Tokyo (JP)

2003/0216182 A1\* 11/2003 Gauselmann ..... G07F 17/32 463/40

(72) Inventor: **Kazuki Emori**, Tokyo (JP)

2005/0239540 A1 10/2005 Inamura  
2006/0205482 A1\* 9/2006 Crivelli ..... G07F 17/32 463/25

(73) Assignee: **Universal Entertainment Corporation**, Tokyo (JP)

2007/0021173 A1\* 1/2007 Seelig ..... G07F 17/32 463/16

(\* ) Notice: Subject to any disclaimer, the term of this patent is extended or adjusted under 35 U.S.C. 154(b) by 0 days.

2007/0026916 A1\* 2/2007 Juds ..... G07F 7/005 463/1

2009/0054149 A1\* 2/2009 Brosnan ..... G07F 17/3244 463/42

2009/0063344 A1\* 3/2009 Travis ..... G06Q 20/1085 705/43

(Continued)

(21) Appl. No.: **16/185,476**

(22) Filed: **Nov. 9, 2018**

*Primary Examiner* — Justin L Myhr

(65) **Prior Publication Data**

US 2019/0156625 A1 May 23, 2019

(74) *Attorney, Agent, or Firm* — Simpson & Simpson, PLLC; S. Peter Konzel

(30) **Foreign Application Priority Data**

Nov. 22, 2017 (JP) ..... JP2017-225176

(57) **ABSTRACT**

(51) **Int. Cl.**  
**G07F 17/32** (2006.01)

[Problem] The object of the present invention is to provide an information processing apparatus that enables a user to reliably perform bet-related processes such as betting.

(52) **U.S. Cl.**  
CPC ..... **G07F 17/3246** (2013.01); **G07F 17/3213** (2013.01); **G07F 17/3227** (2013.01)

[Solution] The information processing apparatus implements: a process of displaying specified currency information corresponding to a bet by an input device to a display device when paper stock read by a reading device has specified currency information, a process of converting the specified currency information corresponding to the bet by the input device to other currency information when the paper stock read by the reading device has other currency information, and a process of displaying the converted other currency information on the display device.

(58) **Field of Classification Search**  
CPC .. G07F 17/32; G07F 17/3246; G07F 17/3213; G07F 17/3223; G07F 17/3227; G07F 17/3251; G07F 17/3211; G07F 17/323; G07F 17/326; G07F 17/3244; G07F 17/3288; G07F 17/3202; G07F 17/3248; G07F 1/06; G07F 7/04; G06Q 20/381; G07D 11/0087; A63F 3/00157

See application file for complete search history.

**17 Claims, 10 Drawing Sheets**

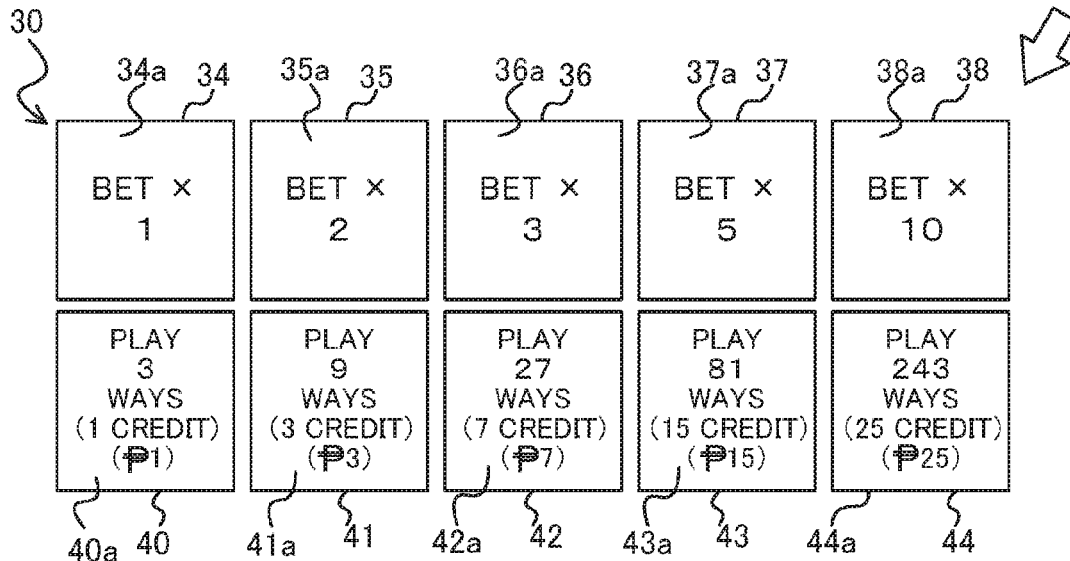

(56)

**References Cited**

U.S. PATENT DOCUMENTS

2009/0215514 A1\* 8/2009 Okada ..... G07F 17/3209  
463/17  
2010/0160022 A1\* 6/2010 Oram ..... G07F 17/32  
463/17  
2013/0084962 A1\* 4/2013 Radisich ..... G07F 17/3244  
463/25  
2013/0123018 A1\* 5/2013 Sareli ..... G07F 17/3223  
463/42  
2013/0217469 A1\* 8/2013 Fujisawa ..... G07F 17/3267  
463/20  
2014/0143073 A1\* 5/2014 Doris-Down ..... G06Q 30/0601  
705/16  
2014/0349742 A1\* 11/2014 Takeda ..... G06Q 30/06  
463/25  
2015/0038217 A1\* 2/2015 Okada ..... G07D 11/14  
463/25

\* cited by examiner

FIG. 1

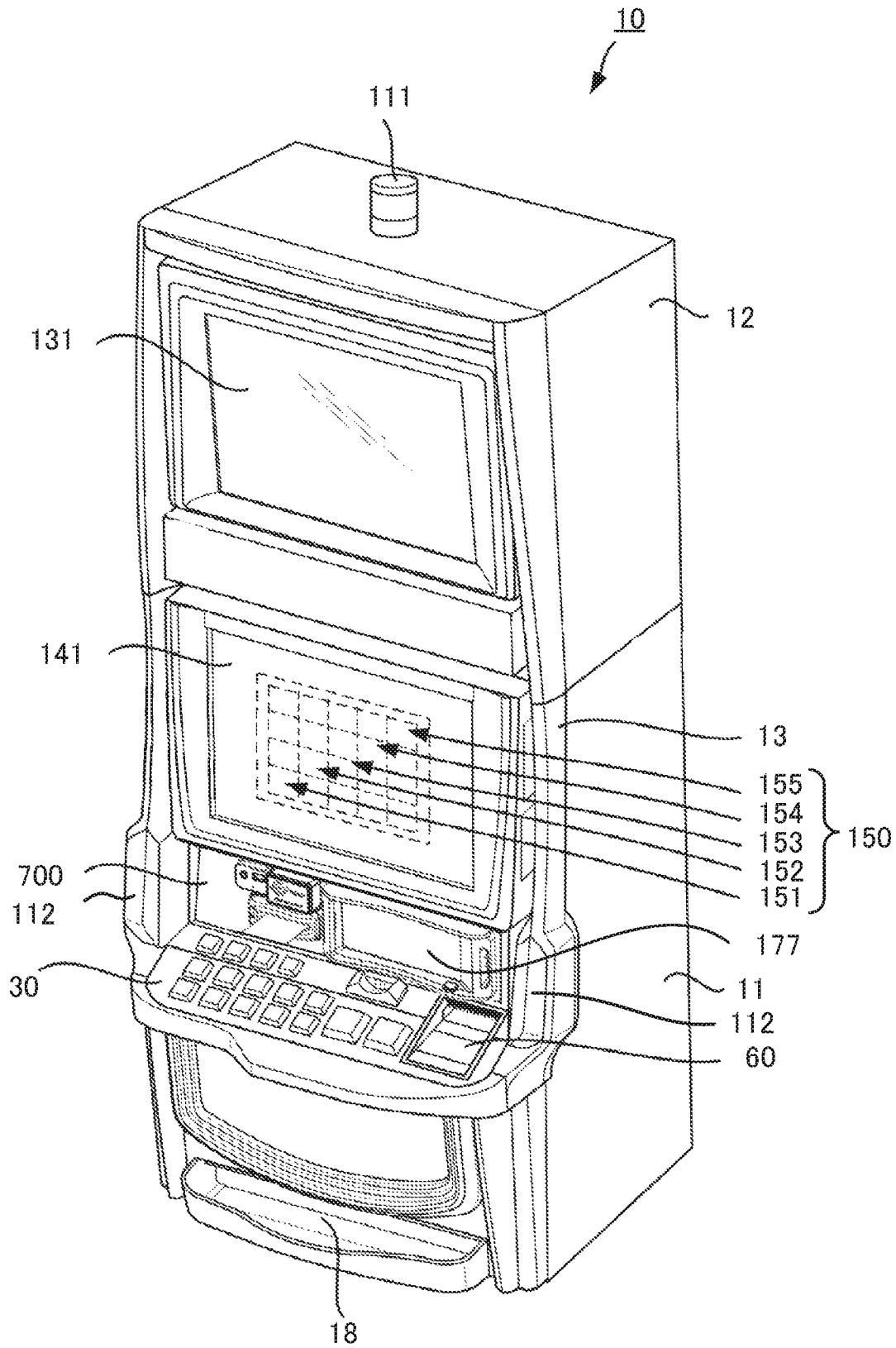

FIG. 2

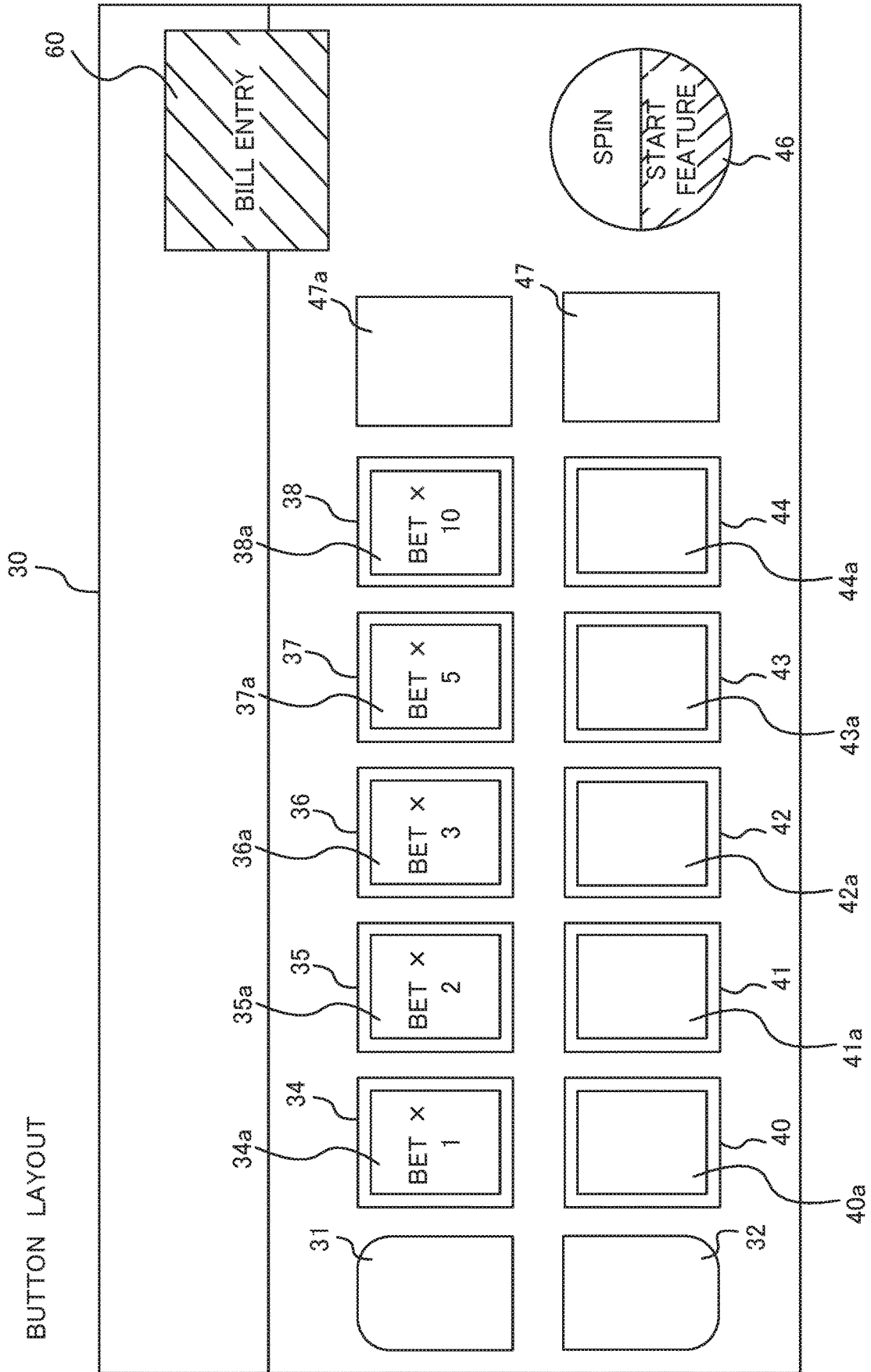

FIG. 3A

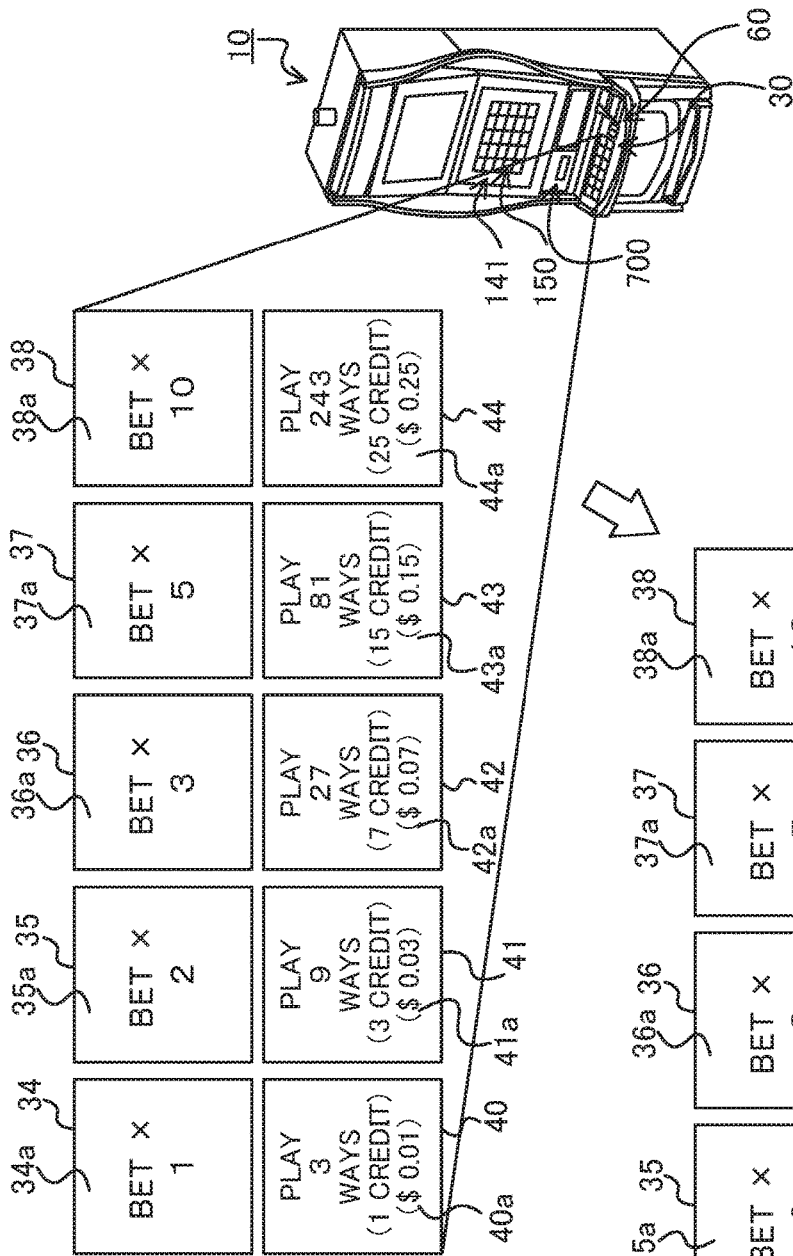

FIG. 3B

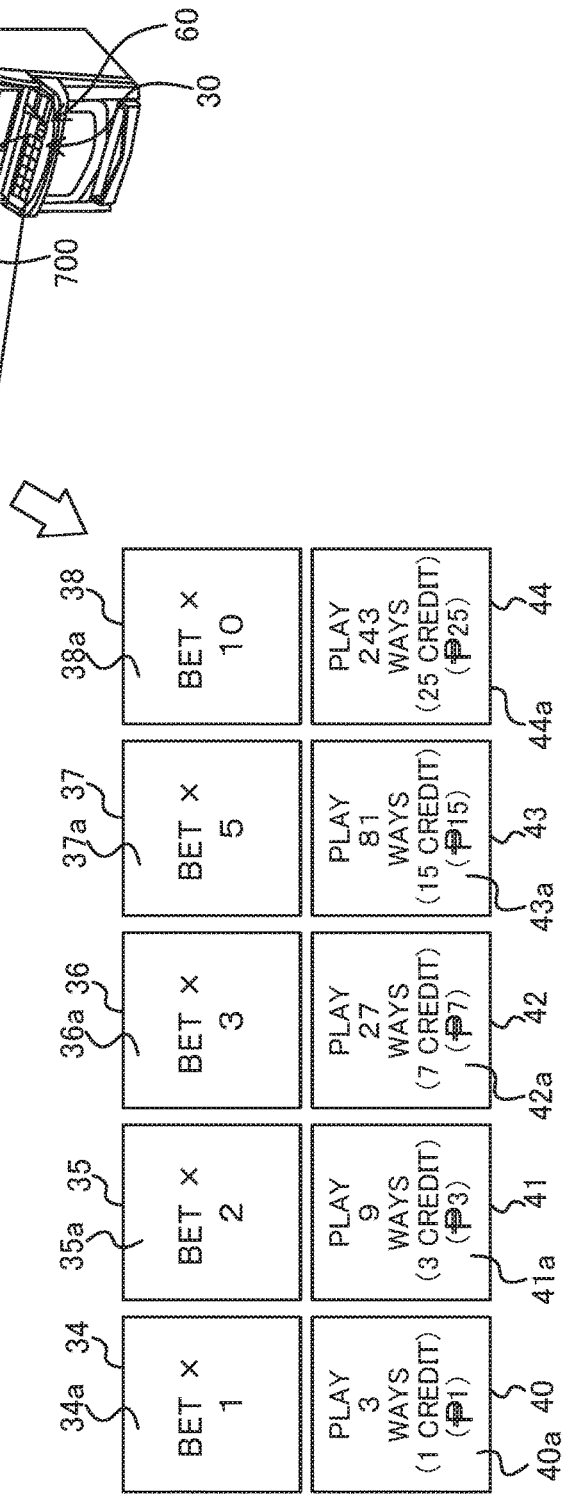

FIG. 4

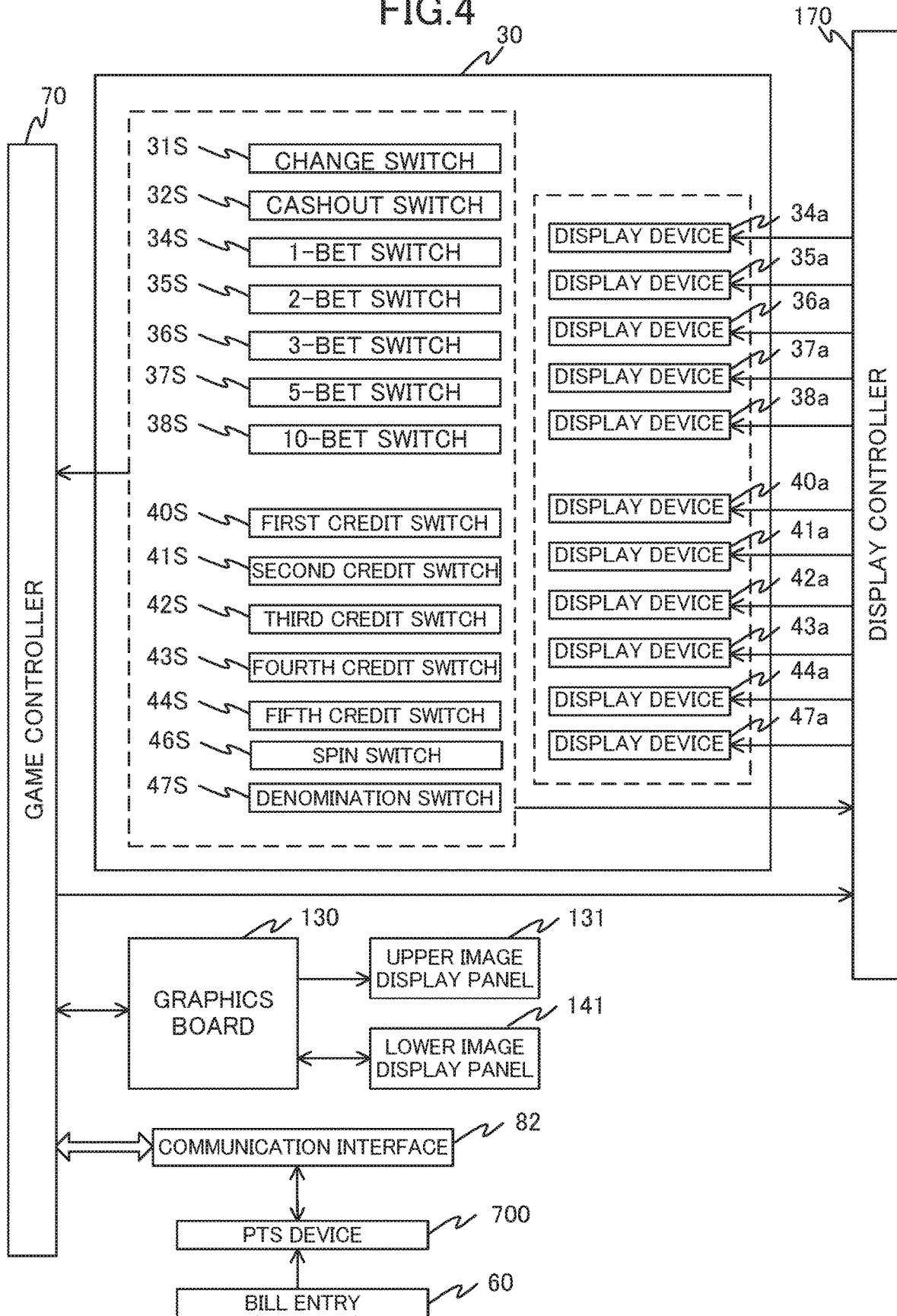

FIG. 5

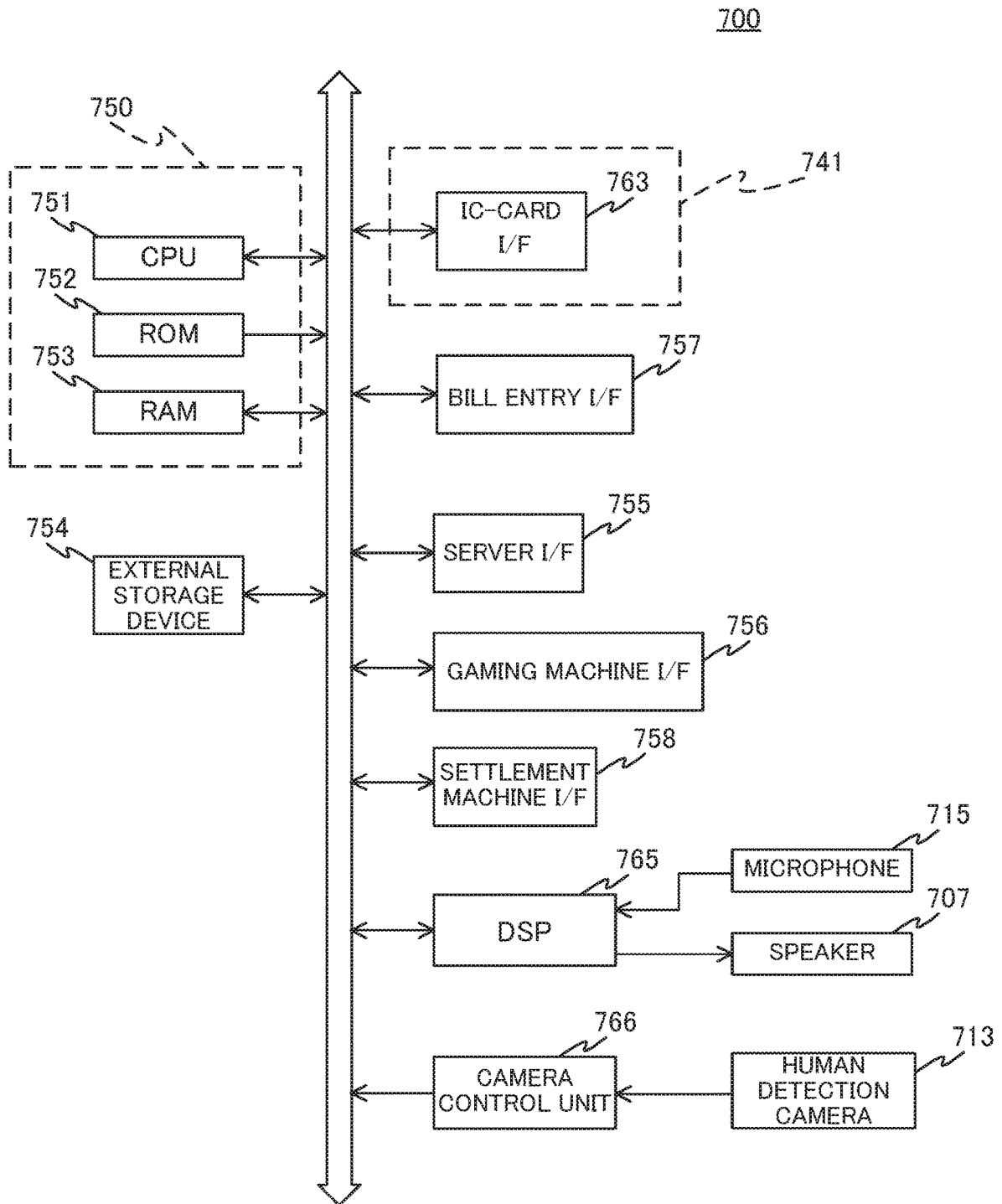

FIG.6A

753  
↙

INSERTED CURRENCY UNIT	Dollars
EXCHANGE RATE	1 peso = 0.01 dollars

FIG.6B

BET AMOUNT TABLE (CREDITS (pesos))

	3WAYS	9WAYS	27WAYS	81WAYS	243WAYS
1-BET	1 (1peso)	3 (3pesos)	7 (7pesos)	15 (15pesos)	25 (25pesos)
2-BET	2 (2pesos)	6 (6pesos)	14 (14pesos)	30 (30pesos)	50 (50pesos)
3-BET	3 (3pesos)	9 (9pesos)	21 (21pesos)	45 (45pesos)	75 (75pesos)
5-BET	5 (5pesos)	15 (15pesos)	35 (35pesos)	75 (75pesos)	125 (125pesos)
10-BET	10 (10pesos)	30 (30pesos)	70 (70pesos)	150 (150pesos)	250 (250pesos)

FIG.6C

BET AMOUNT TABLE (CREDITS (dollars))

	3WAYS	9WAYS	27WAYS	81WAYS	243WAYS
1-BET	1 (0.01 dollars)	3 (0.03 dollars)	7 (0.07 dollars)	15 (0.15 dollars)	25 (0.25 dollars)
2-BET	2 (0.02 dollars)	6 (0.06 dollars)	14 (0.14 dollars)	30 (0.30 dollars)	50 (0.50 dollars)
3-BET	3 (0.03dollars)	9 (0.09 dollars)	21 (0.21 dollars)	45 (0.45 dollars)	75 (0.75 dollars)
5-BET	5 (0.05 dollars)	15 (0.15 dollars)	35 (0.35 dollars)	75 (0.75 dollars)	125 (1.25 dollars)
10-BET	10 (0.10 dollars)	30 (0.30 dollars)	70 (0.70 dollars)	150 (1.50 dollars)	250 (2.50 dollars)



FIG. 7

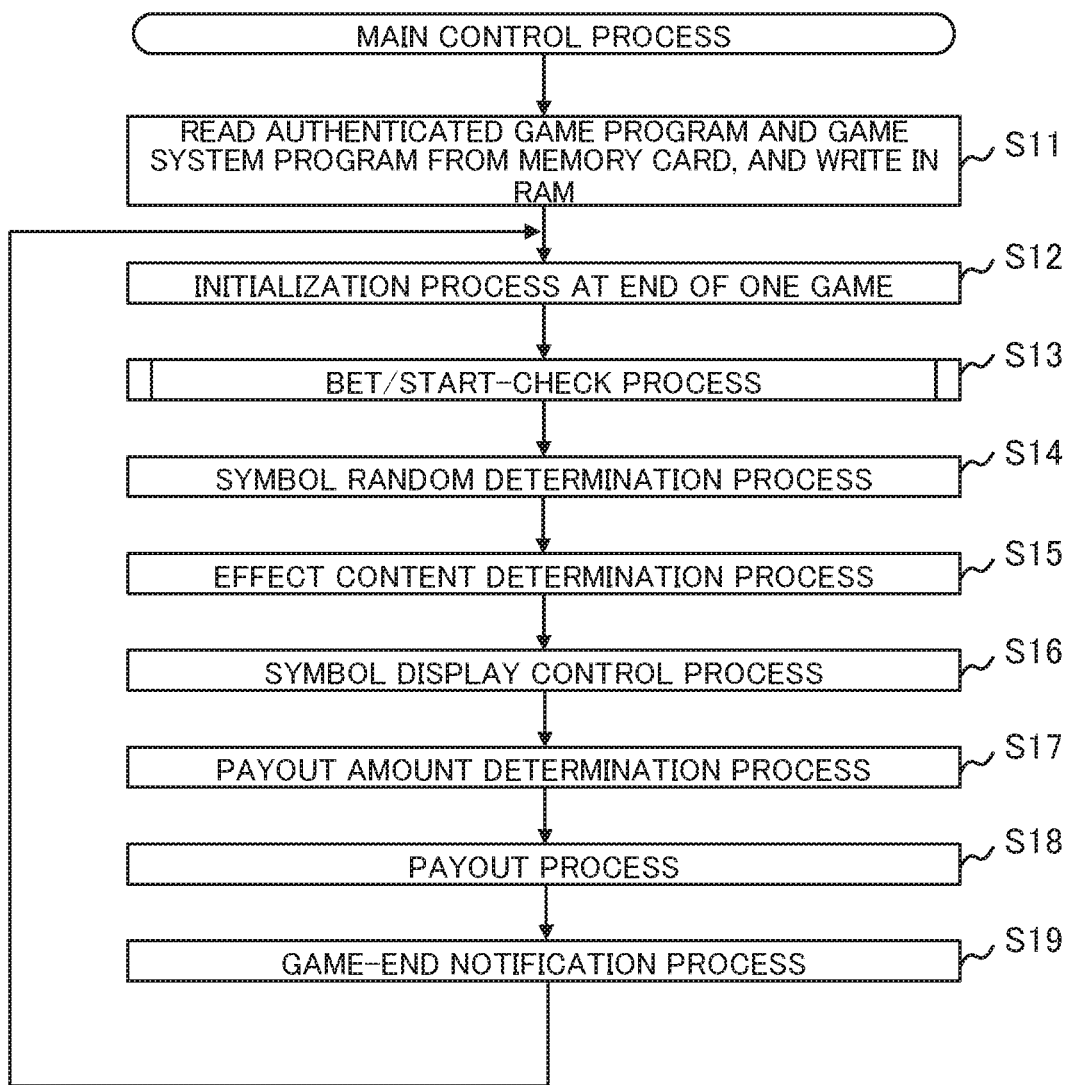

FIG.8

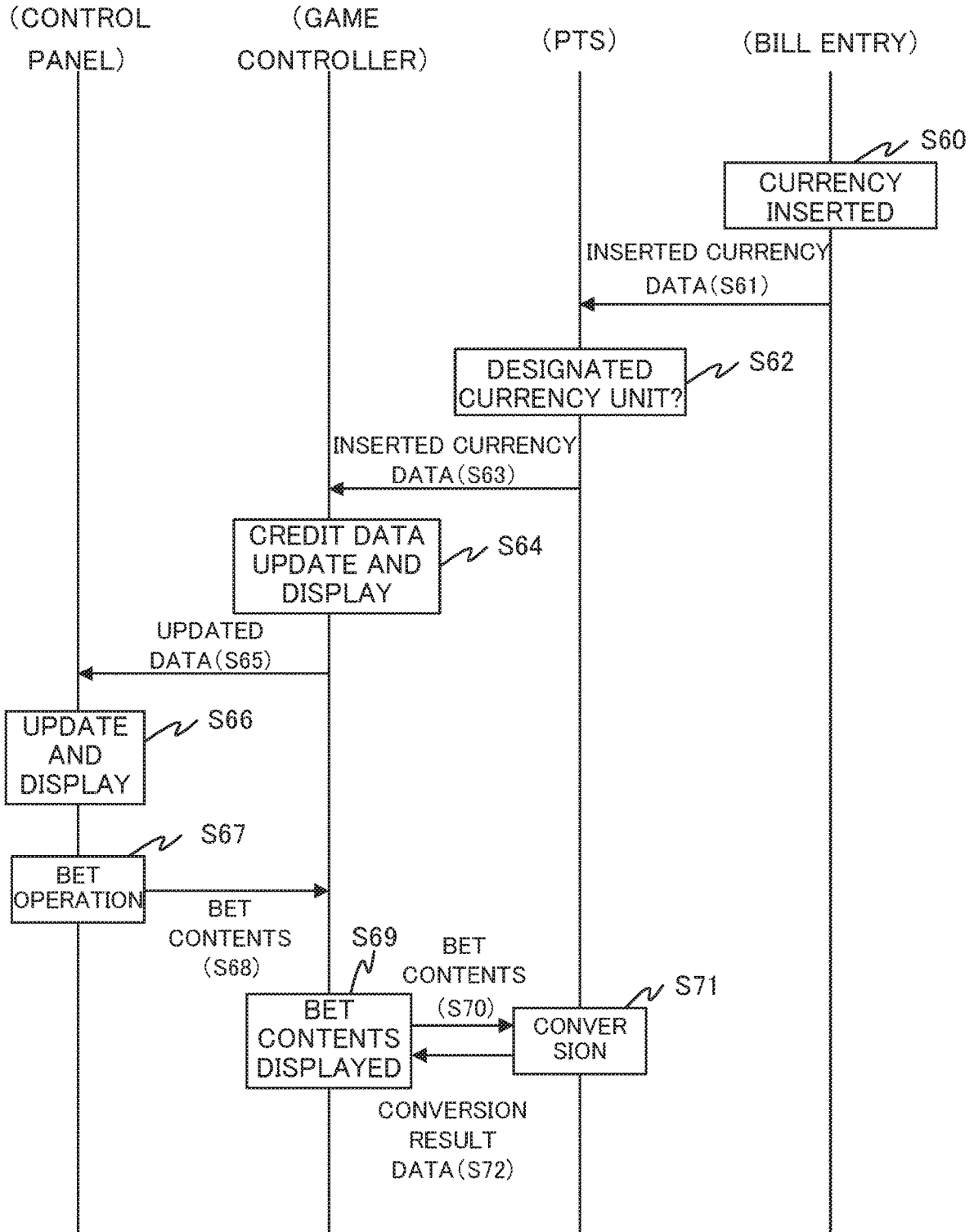

FIG. 9

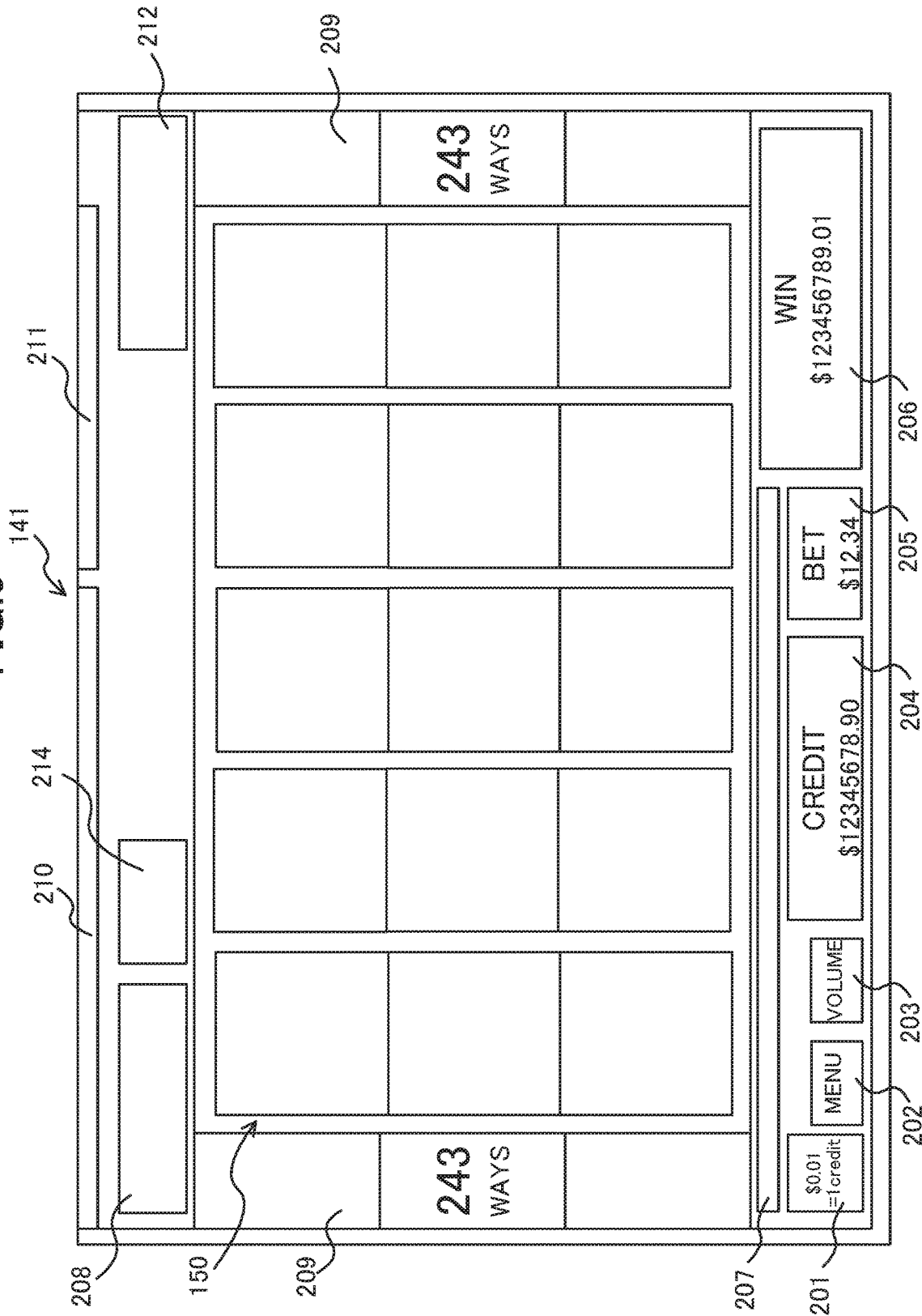

FIG. 10A

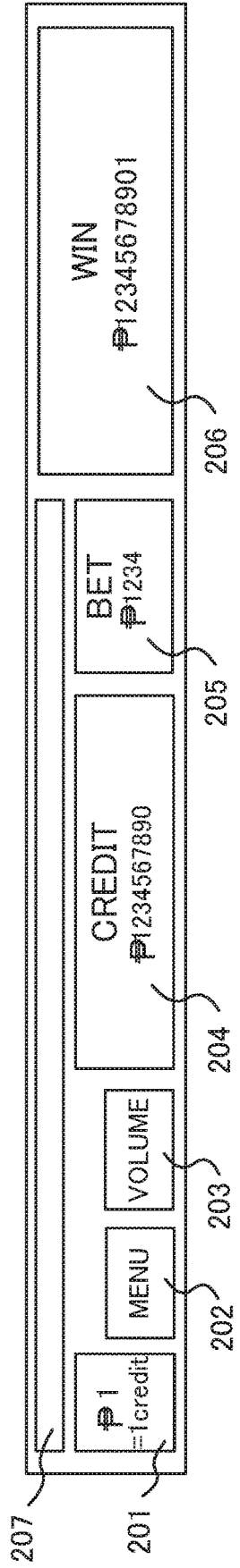

FIG. 10B

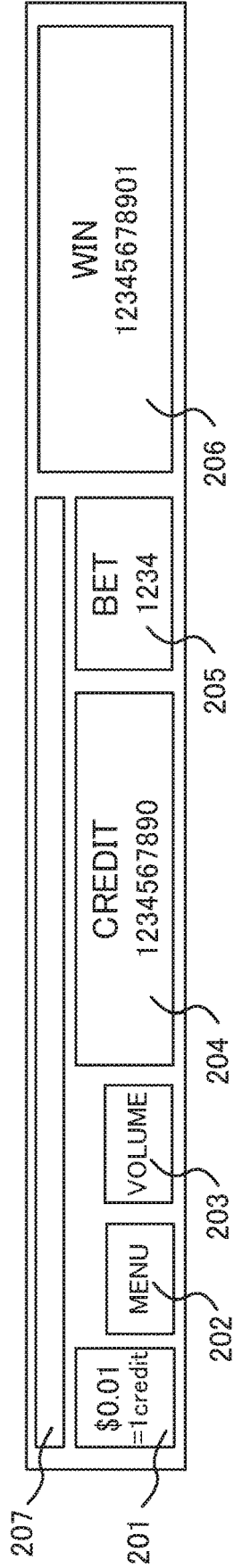
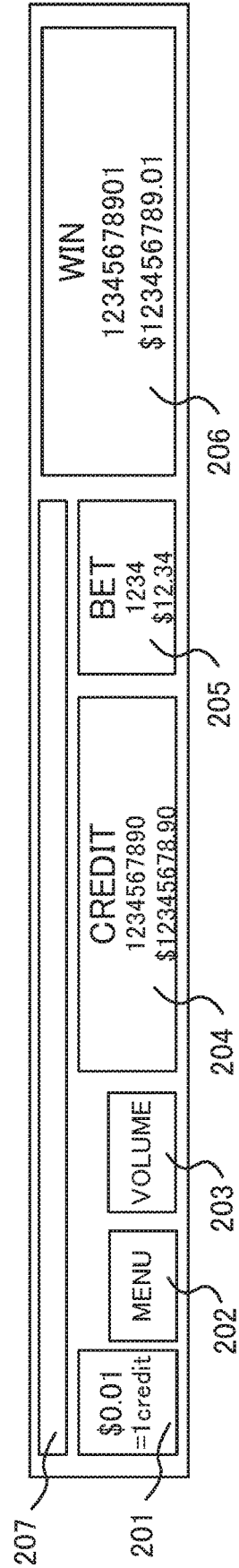

FIG. 10C



1

**INFORMATION PROCESSING APPARATUS  
EXECUTABLE IN A USER SELECTABLE  
MEDIUM OF EXCHANGE**

CROSS-REFERENCE TO RELATED  
APPLICATION

This application claims the benefit of Japanese Patent Application No. 2017-225176, filed on Nov. 22, 2017, which application is incorporated herein by reference in its entirety.

FIELD OF THE INVENTION

The present invention relates to an information processing apparatus capable of inserting multiple currency types.

BACKGROUND OF THE INVENTION

A gaming machine in which a symbol array is scrolled and displayed on a display, and a plurality of symbols are rearranged in a symbol display area, on which a plurality of paylines are set, has been known for example in U.S. Patent Application Publication No. 2005/0239540. In a gaming machine described therein, a player operates a control panel, on which a plurality of buttons are arranged, to decide on bet information for one game.

When a game is played on the above-mentioned gaming machine, as a result of the player inserting cash into a bill identification device provided on the gaming machine, credit data, for playing the game according to the amount of cash inserted, is acquired and the bet information for playing the game one time are determined by using the credit data.

In such a gaming machine, receiving of bets or awarding of prizes is performed based on credit data converted from a predetermined currency unit (e.g., a currency unit such as "pesos"), and when a monetary amount corresponding to the credit amount is displayed, the monetary amount is displayed in the predetermined currency unit.

In this way, in addition to the player preparing cash in a specified currency unit that can be handled by the gaming machine and playing the game by inserting the cash, the amount in the specified currency unit is displayed as the credit amount necessary for the game to progress in the gaming machine. However, it is difficult for the player to understand the displayed monetary amount if the monetary amount is in a currency unit that is different (e.g., "pesos") from a currency unit the player is accustomed to using (e.g., "dollars" for an American).

BRIEF SUMMARY OF THE INVENTION

The present invention has been made in view of the above and provides an information processing apparatus that enables the user to reliably perform bet-related processes such as betting.

The information processing apparatus of the present invention includes: a control device that executes a process based on specified currency information, including the specified currency unit; a display device for displaying the progress of the process of the control device; an input device for inputting a bet, to start the process, based on the specified currency information; an insertion slot into which paper stock inserted, the paper stock having the other currency information that includes the specified currency unit or a currency unit different from the specified currency informa-

2

tion; and a reading device for reading the paper stock that is inserted into the insertion slot; wherein the control device is further configured to:

- (a) display the specified currency information for the bet by the input device to the display device when the paper stock, read by the reading device, has the specified currency information, and (b) convert the specified currency information for the bet by the input device to the other currency information and displays the converted currency information to the display device when the paper stock, read by the reading device, has another currency information.

With this configuration, the player can understand the progress of the process, such as betting by an amount expressed in the currency unit of the currency he/she uses.

Further, in the information processing apparatus of the present invention in the above configuration, the input device has a second display device for displaying a bet amount necessary for starting the process and the currency information corresponding to the bet amount, and the control device, based on the bet amount and the currency information of the paper stock inserted into the insertion slot, performs a control process for displaying either the specified currency information corresponding to the bet amount or other currency information on the second display device.

With this configuration, the player can place bets with a monetary amount displayed in the currency unit of the currency the player himself/herself uses even in the second display device which is provided to the input device.

The present invention provides an information processing apparatus that enables the user to reliably perform bet-related processes such as betting.

BRIEF DESCRIPTION OF THE DRAWINGS

The nature and mode of operation of the present invention will now be more fully described in the following detailed description of the invention taken with the accompanying drawing figures, in which:

FIG. 1 is a perspective view showing an external appearance of a slot machine.

FIG. 2 is a plan view showing a configuration of a control panel.

FIGS. 3A-3B are plan views showing a configuration of a control panel.

FIG. 4 is a block diagram showing an internal configuration of the slot machine and the control panel.

FIG. 5 is a block diagram showing a configuration of a PTS (Player Tracking System) device.

FIG. 6A-6C are schematic diagrams showing a storage state of an exchange rate and a bet amount table.

FIG. 7 is a flowchart showing a main control process.

FIG. 8 is a flowchart showing a bet display process for an inserted currency.

FIG. 9 is a front view showing an example of a display of a lower image display panel.

FIGS. 10A-10C is a schematic diagram showing a portion of the display of the lower image display panel.

DETAILED DESCRIPTION OF THE  
PREFERRED EMBODIMENT

A gaming machine will be described as an information processing apparatus of the present invention with reference to the drawings.

## Overall Structure Of Slot Machine

The overall structure of a slot machine **10** will be described.

In the slot machine **10**, bills, coins, medals, tokens, bar-coded tickets, and the like are used as gaming value in addition to electronic value information such as cyber money.

As shown in FIG. **1**, a lower image display panel **141** is provided at the center of the front surface of a housing **11** of the slot machine **10**. The lower image display panel **141** is a liquid crystal panel and constitutes a display. The lower image display panel **141** has a symbol display area **150** for displaying images of a plurality of video reels **151-155**. A portion of a front panel **13** is provided with a lamp **112** used for effects rendering. Various indicating lamps **111** are provided above the slot machine **10**.

In the present embodiment, a video reel is a reel that simulates the rotation and stop operations of a mechanical reel in which a plurality of symbols are drawn on its peripheral surface. A symbol array composed of a plurality of symbols is assigned to the video reel.

In the present embodiment, a video reel system for displaying a simulated reel is adopted, but the slot machine **10** may be a system with a reel unit of a mechanical reel system, or may be a system in which the video reel and the mechanical system are mixed.

Above the lower image display panel **141**, an upper image display panel **131** is provided on the front of an upper housing **12**. The upper image display panel **131** is a liquid crystal panel and constitutes a display. The upper image display panel **131** displays images related to the effects rendering or images which introduce game contents or explain rules.

Below the lower image display panel **141**, a control panel **30** on which various buttons are arranged, a PTS device **700** that functions as a conversion apparatus, and a bill entry **60** are provided.

The bill entry **60** identifies whether the bill is proper or not and accepts genuine bills into the slot machine **10**. The bill entry **60** is electrically connected to the PTS device **700** and transmits an input signal based on the amount of the bill to the PTS device **700** upon receipt of a genuine bill. The input signal includes inserted currency information (e.g., "1 php") including the currency unit of the inserted bill (Philippine pesos: php (hereinafter simply referred to as "pesos" or "php"), dollars: usd, yen: jpy, etc.) and the monetary amount in the currency unit.

In the present embodiment, in addition to the inserted currency information of the bill inserted into the bill entry **60**, there is a concept of currency information (e.g., "1 php, 1 credit"). This currency information is a concept that includes a currency unit ("php (pesos)," "usd (dollars)," "jpy (yen)," etc.), the monetary amount in this currency unit (e.g., "1 php (peso)," etc.), and the credit amount corresponding to the monetary amount information (e.g., "1 php, 1 credit," etc.).

In the slot machine **10** of the present embodiment, one credit, which is a unit of a gaming medium for playing a game, is associated with a monetary amount in "pesos" as a specified currency unit, and currency information with one credit as one peso is set as basic currency information. The monetary amount per credit (1 credit=1 peso) can be switched by a denomination button **47** described later. As described above, in the slot machine **10**, a specified currency unit ("pesos") is set as the currency information in advance as the currency unit to be handled when the process is

performed so that when the currency unit of a bill inserted into the bill entry **60** is a currency unit (for example, "dollars") other than the specified currency unit, the PTS device **700** converts the currency unit into currency information that is based on the basic currency information "1 php, 1 credit" in the specified currency unit ("pesos"). That is, the bill entry **60** has a function of identifying the currency type ("pesos", "dollars", "yen", etc.) and the monetary amount corresponding to the inserted bill, and when, for example, a dollar bill is inserted into the bill entry **60**, the bill entry **60** transmits the inserted currency information including the currency unit information indicating that the currency unit of the inserted bill is "dollars" and the amount information indicating the monetary amount (one dollar) to the PTS device **700**. In the PTS device **700**, this information is converted to "pesos", which is a specified currency type, based on an exchange rate. For example, when a 1 dollar bill is inserted, the PTS device **700** converts "dollars" to "pesos" based on the inserted currency information transmitted from the bill entry **60** and current exchange rate information (e.g., 1 usd=51 php) and converts it to currency information (e.g., 51 php, 51 credits). Currency information in the specified currency unit calculated in this manner is transmitted from the PTS device **700** to the game controller **70** of the slot machine **10**, which will be described later.

The PTS device **700** is a unit in which an LCD (i.e., a liquid crystal display) **177**, a human detection camera **713**, a microphone **715**, a speaker **707**, and the like are integrated. The human detection camera **713** makes it possible to detect the presence or absence of a player with a camera. The microphone **715** is used by the player to participate in the game by voice or to authenticate the player by voice recognition. Further, the PTS device **700** has a card insertion slot to allow insertion of an IC card. Thus, the player can insert the IC card into the card insertion slot and use credit, stored on the IC card, in the slot machine **10**.

Control Panel **30**

As shown in FIG. **2**, the control panel **30** has a CHANGE button **31** and a CASHOUT/TAKE WIN button **32** arranged in the left area, and a 1-BET button **34**, a 2-BET button **35**, a 3-BET button **36**, a 5-BET button **37**, a 10-BET button **38**, a first credit button **40**, a second credit button **41**, a third credit button **42**, a fourth credit button **43**, and a fifth credit button **44** arranged in the center area. Further, the control panel **30** is provided with the above-mentioned bill entry **60** disposed in the upper stage of the right side region and a spin button **46** disposed in the lower stage of the right side area. A denomination button **47** for switching the amount of money per credit is also provided.

The CHANGE button **31** is an operation button used when leaving a seat or to request a staff member of a gaming facility to exchange money. The CASHOUT/TAKE WIN button **32** is an operation button used for settling credits deposited in the slot machine **10**.

The first credit button **40**, the second credit button **41**, the third credit button **42**, the fourth credit button **43**, and the fifth credit button **44** are used for selecting the target areas for winning from **15** areas of 5 columns×3 rows on the symbol display area **150**. The first credit button **40**, the second credit button **41**, the third credit button **42**, the fourth credit button **43**, and the fifth credit button **44** each have display devices **40a**, **41a**, **42a**, **43a**, **44a**.

The display devices **40a**, **41a**, **42a**, **43a**, **44a** are liquid crystal devices provided on the upper surfaces of the first

credit button 40, the second credit button 41, the third credit button 42, the fourth credit button 43, and the fifth credit button 44, respectively.

The 1-BET button 34, the 2-BET button 35, the 3-BET button 36, the 5-BET button 37, and the 10-BET button 38 are buttons for determining a payout ratio with respect to a basic bet amount. The 1-BET button 34, the 2-BET button 35, the 3-BET button 36, the 5-BET button 37, and the 10-BET button 38 each have a display device 34a, 35a, 36a, 37a, 38a, respectively.

The display devices 34a, 35a, 36a, 37a, 38a are liquid crystal devices provided on the upper surface of the 1-BET button 34, the 2-BET button 35, the 3-BET button 36, the 5-BET button 37, and the 10-BET button 38, respectively.

In the present embodiment, a unit game is started when the credit amount (i.e., the bet amount) to be bet is determined by selecting an area (i.e., a selection from the five-step WAYS BET (WAYS BET1, WAYS BET2, WAYS BET3, WAYS BET4, WAYS BET5)) of the symbol display area 150 to be the result determination target and a payout (i.e., a selection from the six BET buttons (1-BET button 34, 2-BET button 35, 3-BET button 36, 5-BET button 37, 10-BET button 38)).

For example, a value obtained by multiplying the number of credits corresponding to the BET button by the credit amount required for the WAYS BET (i.e., 1 credit for WAYS BET1, 3 credits for WAYS BET2, 7 credits for WAYS BET3, 15 credits for WAYS BET4, and 25 credits for WAYS BET5) becomes the credit amount that is bet at the time of starting the unit game. For example, when the first credit button 40 and the 2-BET button 35 associated with "WAYS BET1" are selected, "1"×"2"=2 credits are bet. When the third credit button 42 and the 3-BET button 36 associated with "WAYS BET3" are selected, "7"×"3"=21 credits are bet. When the fifth credit button 44 and the 10-BET button 38 associated with "WAYS BET5" are selected, "25"×"10"=250 credits are bet.

The spin button 46 is a button used to start scrolling the video reel. The spin button 46 is also used for selecting and determining picks displayed on the lower image display panel 141.

The denomination button 47 is a button for changing the monetary amount per credit, and a display device 47a configured with a liquid crystal device is provided adjacent to the denomination button 47. The monetary amount per credit is displayed on the display device 47a. When the denomination switch 47S shown in FIG. 4 is switched on by operating the denomination button 47, the monetary amount per credit displayed on the display device 47a is changed. That is, the player can change the monetary amount per credit by operating the denomination button 47 while watching the display of the display device 47a.

The monetary amount per credit displayed on the display device 47a is displayed as a monetary amount in the currency unit inserted by the player. Specifically, when the bill inserted into the bill entry 60 is, for example, "dollars", the inserted currency information that includes the currency unit and the monetary amount of the inserted bill is transmitted from the bill entry 60 to the PTS device 700. Even if the basic currency information in the slot machine 10 is set to "pesos" as the currency information per credit, the PTS device 700 displays the currency information in units of the inserted currency (for example, "dollars") on the display device 47a of the control panel 30 and the lower image display panel 141 (to be described later) of the slot machine 10 with an amount (for example, "1 credit=\$0.01") reflecting the current currency exchange rate. In this display

control process, the PTS device 700 directly controls the display of the display device 47a and the lower image display panel 141, but the present invention is not limited to this, and information for controlling the display may be transmitted from the PTS device 700 to the game controller 70, and controlling the display may be performed by the game controller 70. Further, by transmitting the inserted currency information from the bill entry 60 to the game controller 70 without using the PTS device 700, the monetary amount per credit may be calculated based on the exchange rate in the game controller 70, and the calculated amount may be displayed on the display device 47a and the lower image display panel 141.

As described above, the monetary amount per credit converted into the currency inserted by the player is displayed on the control panel 30, but in the slot machine 10, "pesos" is set as the specified currency unit, and therefore, in the process of the game controller 70, even when the bill inserted into the bill entry 60 is not of the specified currency unit (e.g., "pesos"), the monetary amount per credit is the monetary amount converted into the specified currency "pesos" and the processing of granting a bet or an award is performed according to the monetary amount in the specified currency.

That is, by operating the denomination button 47 while observing the display amount converted into "dollars" on the display device 47a of the control panel 30, the player can set the monetary amount per credit while observing the display amount converted into "dollars" which is the currency unit inserted by the player rather than the specified currency unit ("pesos") handled by the slot machine 10. Specifically, when the denomination button 47 is sequentially pressed, the display of the display device 47a is sequentially changed to "\$0.01", "\$0.1", and so on. The change result is transmitted from the control panel 30 to the PTS device 700. In the PTS device 700, the monetary amount per credit (i.e., the monetary amount converted in dollars) set by the denomination button 47 is converted into an amount of a specified currency unit (e.g., "pesos") handled by the slot machine 10, and the conversion result is transmitted to the game controller 70 (described later) of the slot machine 10. As a result, the game controller 70 performs the betting process and the process related to awarding a prize according to the result of converting the monetary amount per credit set by the player into the monetary amount in the specified currency unit ("pesos") (e.g., 1 peso per credit). The display for denomination switching in the lower image display panel 141 is configured to perform the same operation as the display and switching operation of the denomination button 47. The denomination indicator display and switching in the lower image display panel 141 are controlled from the PTS device 700 via the game controller 70 or controlled directly.

#### Description of Control Panel Functions

The control panel 30 of the present embodiment includes credit buttons 40, 41, 42, 43, 44 (i.e., a first credit button 40, a second credit button 41, a third credit button 42, a fourth credit button 43, and a fifth credit button 44) as a plurality of bet amount input devices for selecting bet objects. Each of the credit buttons 40, 41, 42, 43, 44 is provided with a display device 40a, 41a, 42a, 43a, 44a which can be seen from the outside, and different basic bet amounts are set according to differences in advantages.

Further, the control panel 30 is provided with bet buttons 34, 35, 36, 37, 38 (i.e., the 1-BET button 34, the 2-BET button 35, the 3-BET button 36, the 5-BET button 37, the

10-BET button **38**) as a plurality of multiplying factor input devices which allow the player to select the payout ratio. Each of the plurality of multiplying factor input devices is mapped to a different payout ratio. The bet buttons **34, 35, 36, 37, 38** include display devices **34a, 35a, 36a, 37a, 38a** that are visible from the outside, and display the payout ratio.

When one of the bet buttons **34, 35, 36, 37, 38** receives an input, the control panel **30** of the slot machine **10** displays values obtained by multiplying each set basic bet amount by a payout ratio, corresponding to the bet button **34-38** that received the input, on the display devices **40a, 41a, 42a, 43a, 44a** of each of the credit buttons **40, 41, 42, 43, 44**. Further, the display devices **40a, 41a, 42a, 43a, 44a** display an amount obtained by multiplying the basic bet amount by the payout ratio corresponding to the bet button **34-38** that received the input, which is converted to the currency unit (for example, "dollars") inserted by the player. For example, in FIG. 3A, when the 1-BET button **34** is operated, the display devices **40a, 41a, 42a, 43a, 44a** display 1, 3, 7, 15, and 25 credits, respectively, as values obtained by multiplying the basic bet amount set for the credit buttons **40, 41, 42, 43, 44** by the payout ratio corresponding to the bet button **34-38** that received the input, and displays \$0.01, \$0.03, \$0.07, \$0.15, \$0.25 in the respective currency unit. That is, a player who has inserted a dollar bill into the bill entry **60** can see the amount converted and displayed in "dollars" as the currency unit on each of the credit buttons **40, 41, 42, 43, 44**. For example, with respect to the display of 1, 3, 7, 15, and 25 credits displayed as bet amounts in the display devices **40a, 41a, 42a, 43a, 44a**, respectively, when 1 BET button **34** is inputted, the monetary amount converted to "dollars," which the player himself/herself is accustomed to, is displayed together with the credit display. Thus, when the player designates 1-BET, the display devices **40a, 41a, 42a, 43a, 44a** of each of the credit buttons **40, 41, 42, 43, 44** requires 1, 3, 7, 15, 25 credits when placing bets corresponding to WAYS BET1, WAYS BET2, WAYS BET3, WAYS BET4, and WAYS BET5, and the player can easily recognize that these credits are converted into the currency unit of the inserted currency and correspond to \$0.01, \$0.03, \$0.07, \$0.15, and \$0.25, respectively. For instance, when the bill inserted into the bill entry **60** is "pesos", each credit amount is converted into the corresponding "pesos" of which amount is displayed together with the symbol "php" representing the currency "pesos".

More specifically, in the control panel **30** shown in FIG. 3A, when the bill with a currency unit of "pesos" is inserted into the bill entry **60** under the condition that the display contents of the display devices **40a to 44a** are "PLAY 3 WAYS (1 CREDIT)(\$0.01)", "PLAY 9 WAYS (3 CREDITS) (\$0.03)", "PLAY 27 WAYS (7 CREDITS) (\$0.07)", "PLAY 81 WAYS (15 CREDITS) (\$0.15)", "PLAY 243 WAYS (25 CREDITS) (\$0.25)", respectively, the PTS device **700** transmits to the game controller **70** that the currency unit of the inserted currency is "pesos" based on the inserted currency information outputted from the bill entry **60**. As a result, the game controller **70** switches the display of each of the display devices **40a-44a** of the control panel **30** via a display controller **170** to information having a currency unit of "pesos" as shown in FIG. 3B. That is, when the game controller **70** determines that the currency unit of the inserted bill is "pesos," the amount displayed on each display device **40a-44a** of the control panel **30** (i.e., the monetary amount corresponding to the credit amount) is switched from the display of the monetary amount in the currency unit of "dollars" used until this time to the display

of the monetary amount in the currency unit of "pesos". Conversion between currency units is performed by the PTS device **700**. In this case, the amount is displayed together with a symbol representing the currency unit "pesos" (e.g., a symbol obtained by adding two horizontal lines to "P") or an image which can be associated with "pesos". The notation of the currency unit "pesos" is not limited to symbols shown in the respective display devices **40a-44a** in FIG. 3B, and various other notations can be used, for example, characters representing the currency unit of "pesos" such as "1 php" or characters representing the currency unit printed on a bank note such as "1 PISO" can be used.

#### Internal Configuration of Slot Machine

Next, an internal configuration of the slot machine **10** and the control panel **30** provided in the slot machine **10** will be described with reference to FIG. 4.

The game controller **70** is provided on a game circuit board inside the slot machine **10**. The display controller **170** is provided inside the control panel on a control panel circuit board different from the game circuit board of the game controller **70**. The game controller **70** and the display controller **170** each include a CPU (Central Processing Unit) provided on a circuit board for a game and a circuit board for a control panel, a program executed by the CPU and an EEPROM (Electrically Erasable and Programmable Read Only Memory) for rewritably storing data used in these programs, and a Random Access Memory (RAM) for temporarily storing data when the program is being executed. The game controller **70** and the display controller **170** are constructed by cooperation of the hardware and software, in the storage device as described above. Note that the display controller **170** is not limited to being provided separately from the game controller **70**, and the game controller **70** may have the function of the display controller **170**.

For example, data and programs used when the CPU operates are stored in the storage device of the game controller **70**. For example, the game controller **70** may store the aforementioned game programs, game system programs, and authentication programs when they are imported from an external storage device. The storage device of the game controller **70** is provided with a work area for executing the program. For example, an area for storing the credit amount, the number of BETs, the number of payout amounts, the credit amounts, and the like, an area for storing a symbol (i.e., a code number) determined by a random determination, and the like are provided.

As described above, the game controller **70** executes the game, and controls the symbol display device **150** so as to rearrange the symbols according to the game. The game controller **70**, as described above, activates a number of winning lines corresponding to the credit buttons **40, 41, 42, 43, 44** that have received input in a display frame of three rows and five columns consisting of a plurality of blocks, and provides a line payout corresponding to the type of symbol when the same number of symbols of the same type is rearranged in the enabled winning lines. That is, the game controller **70** is configured to control the slot machine by way of the CPU executing the game program or the game system program in the storage device. The display controller **170** has a graphics board and displays the bet amount required for the display devices **40a, 41a, 42a, 43a, 44a** of the credit buttons **40, 41, 42, 43, 44**.

The control panel **30** is provided with a CHANGE switch **31S**, a CASHOUT switch **32S**, a 1-BET switch **34S**, a 2-BET switch **35S**, a 3-BET switch **36S**, a 5-BET switch



37S, a 10-BET switch 38S, a first credit switch 40S, a second credit switch 41S, a third credit switch 42S, a fourth credit switch 43S, a fifth credit switch 44S, a spin switch 46S, and a denomination switch 47S corresponding to the buttons described above. Each switch detects that the corresponding button has been pressed by the player, and outputs a signal to the game controller 70 and the display controller 170. The game controller 70 controls betting based on signals from the respective switches. The display controller 170 transmits signals from the respective switches to the game controller 70, and the game controller 70 determines the contents to be displayed on the display devices 34a to 38a and 40a to 44a provided on the buttons 34 to 38 and 40 to 44 based on these signals, and transmits the determination result to the display controller 170, thereby causing the buttons to be displayed.

In addition to a speaker, a touch panel, and the like, a graphics board 130, a power supply unit 81, and a communication interface 82 are connected to the game controller 70.

The graphics board 130 controls display of images displayed by the upper image display panel 131 and the lower image display panel 141 based on control signals outputted by the game controller 70. The graphics board 130 includes a VDP for generating image data, a video RAM for storing image data generated by the VDP, and the like.

The graphics board 130 includes a VDP (Video Display Processor) for generating image data based on control signals outputted from the game controller 70, a video RAM for temporarily storing image data generated by the VDP, and the like. The image data used when image data is generated by the VDP is included in the game program of the storage device. The graphics board 130 has a function of outputting operation results of various touch icons provided on the lower image display panel 141 to the game controller 70.

The communication interface 82 is for performing communication with the PTS device 700 and an external controller. When an input signal is received from the bill entry 60, the PTS device 700 transmits the inserted currency information contained in the input signal to the game controller 70 via the communication interface 82. When an IC card is inserted into the card insertion slot, the PTS device 700 transmits credit data stored on the IC card to the game controller 70 via the communication interface 82. The PTS device 700 writes credit data to the IC card inserted into the card insertion slot based on the control signal received from the game controller 70 via the communication interface 82.

The game controller 70 is also enabled to transmit signals to the display controller 170 using known communication protocols and connections. For example, the game controller 70 transmits, to the display controller 170, a signal indicating whether or not various buttons can accept inputs.

#### Configuration of the PTS Device

Next, a configuration of a circuit in the PTS device 700 will be described with reference to FIG. 5.

The PTS controller 750 for controlling the PTS device 700 includes a CPU 751, a ROM 752, and a RAM 753.

The CPU 751 executes and controls the components of the PTS device 700 and executes and calculates various programs stored in the ROM 752.

The ROM 752 comprises a memory device such as a flash memory unit, in which permanent data to be executed by the CPU 751 is stored. For example, a credit updating program or the like for rewriting credit-related data stored on an IC

card (not shown) connected via an IC-card I/F (interface) 763 can be stored in the ROM 752.

The RAM 753 temporarily stores data required for executing various programs stored in the ROM 752.

The external storage device 754 is, for example, a storage device such as a hard disk drive, and stores a program executed by the CPU 751 and data used by the program executed by the CPU 751.

A server I/F 755 implements data communication between an external server such as a hall management server and the PTS device 700. The gaming machine I/F (interface) 756 implements data communication between the game controller 70 of the slot machine 10 and the PTS device 700 via the communication interface 82 (see FIG. 4) on the slot machine 10 side, and a prescribed protocol can be used for the data communication.

Further, the PTS device 700 is connected to the bill entry 60, which is a bill validator, via a bill entry I/F (interface) 757, and is also connected to a settlement machine (not shown) via a settlement machine I/F (interface) 758, and can transmit and receive data to and from the settlement machine as necessary.

The IC card control unit 741 controls insertion and ejection of an IC card, writing of credit data, and the like. The IC card control unit 741 includes an IC card R/W (reader/writer) control unit, an IC card suction/discharge control unit, an LED control unit, and the like.

The DSP 765 receives audio data acquired from the microphone 715, performs a predetermined audio process, and then transmits the data to the CPU 751. The DSP 765 also transmits the received audio data to the speaker 707. Further, the DSP 765 outputs the received sound to headphones through an audio terminal connected to the headphones, processes the sound received from the microphone, and transmits the processed sound to the CPU 751. Here, a schematic configuration is shown, and an A/D converter, a D/A converter, an amplifier, and the like are omitted.

A camera control unit 766 acquires an image of the player or the like captured by the human detection camera 713, performs predetermined image processing as required, and transmits the processed data to the CPU 751. The data is transmitted to, for example, a hall management server via the server I/F 755.

#### Data Table

In the PTS device 700 illustrated in FIGS. 4 and 5, when a currency such as a bill is inserted into the bill entry 60, the inserted currency information (i.e., currency unit, amount) outputted from the bill entry 60 is stored in the RAM 753. As shown in FIG. 6A, in the storage area of the RAM 753, the exchange rate of the currency unit (for example, "dollars") of the bill inserted by the player and the specified currency unit (for example, "pesos") set in the slot machine 10 are stored.

Each time a currency is received at the bill entry 60, the CPU 751 communicates with external servers to obtain the exchange rate between the relevant currency unit and the specified currency unit. For example, when the inserted currency is "dollars," the CPU 751 obtains the exchange rate of "dollars" and "pesos", which is a particular currency unit, from outside and stores the exchange rate in the RAM 753.

Thus, in response to a request from the game controller 70 of the slot machine 10, the PTS device 700 can convert the monetary amount of the prize generated in accordance with the progress of the game, for example, from the specified currency unit (e.g., "pesos") used in the processing of the

slot machine **10** (i.e., the game controller **70**) to a currency unit (e.g., “dollars”) of the bill inserted by the player at this time, and return the result to the game controller **70**. The result of the conversion (e.g., the amount in “dollars”) is displayed on the display panel (i.e., the upper image display panel **131** or the lower image display panel **141**, etc.) of the slot machine **10**. That is, in the slot machine **10** that processes a game in the specified currency unit (e.g., “pesos”), the monetary amount of a prize or the like generated by the progress of the game is displayed in a monetary amount converted into the currency unit (e.g., “dollars”) inserted by the player, and the monetary amount can be displayed in a currency that the player is accustomed to.

The game controller **70** shown in FIG. 4 has a bet amount table in which the credit buttons **40**, **41**, **42**, **43**, **44** and the bet buttons **34**, **35**, **36**, **37**, **38** are mapped to each other in the storage device.

As shown in FIGS. 6B and 6C, the bet amount table stores bet amounts mapped to a plurality of payout ratios (1-BET, 2-BET, 3-BET, 5-BET, 10-BET) and a plurality of basic bets (3WAYS, 9WAYS, 27WAYS, 81WAYS, 243WAYS).

For example, when the second credit button **41** is inputted, the credit amounts (2, 6, 14, 30, 50) in the row 2-BET is displayed on the display devices **40a**, **41a**, **42a**, **43a**, **44a**, respectively.

Further, each bet amount stored in the bet amount table shown in FIGS. 6B and 6C is stored in a currency amount mapped to each bet amount. The currency amount includes specified currency information such as an amount represented in the currency of “pesos” per credit (for example, one credit is one peso) when the specified currency unit set in advance in the slot machine **10** is “pesos.” In the bet amount table, a relationship between a currency unit (e.g., “dollars”) other than the specified currency unit and a credit (e.g., one credit is \$0.01) is stored as other currency information (i.e., currency information including a currency unit other than a specified currency unit). This table is periodically overwritten to reflect the current exchange rate. Although the relationship between “pesos”, “dollars”, and credits is tabulated in FIGS. 6B and 6C, other currency types are also taken in and tabulated as appropriate. Further, the bet amount table shown in FIGS. 6B and 6C, may be provided to, for example, the PTS device **700**, the display controller **170**, or the like instead of the game controller **70**.

#### Program Content

Next, a program executed by the game controller **70** of the slot machine **10** will be described.

#### Main Control Process

First, a main control process will be described with reference to FIG. 7.

First, when the slot machine **10** is powered on, the game controller **70** reads out the game program and the game system program and writes them in the RAM (S11).

Next, in order to start the game, the game controller **70** performs an initialization process at the end of one game (S12). For example, unnecessary data is cleared for each game in a single normal mode in the RAM work area, such as the bet amounts and symbols determined by random determination.

Next, the game controller **70** performs a bet/start-check process, which will be described later (S13). In this process, the inputs of the 1-BET switch **34S**, the 2-BET switch **35S**, the 3-BET switch **36S**, the 5-BET switch **37S**, the 10-BET

switch **38S**, the first credit switch **40S**, the second credit switch **41S**, the third credit switch **42S**, the fourth credit switch **43S**, the fifth credit switch **44S**, the spin switch **46S**, the denomination switch **47S**, and the like are checked. In the bet/start-check process (S13), when insertion information indicating that a bill has been newly inserted is received from the PTS device **700**, the game controller **70** updates the specified currency information (i.e., the monetary amount shown in a particular currency “pesos” and the credit amount corresponding to the monetary amount) stored in the game controller **70** for the player to play the game. Specifically, the specified currency information converted from the amount of the newly inserted bill is added to the specified currency information already stored in the storage unit. That is, the slot machine **10** is configured to perform game processing (i.e., betting, payout calculation, payout, etc.) in the specified currency unit (e.g., “pesos”), and in the game controller **70**, the monetary amount of the bill inserted by the player or the award given as a result of a game is managed as specified currency information in the specified currency unit.

When a bill of the specified currency unit (e.g., “pesos”) is inserted into the bill entry **60**, the monetary amount of the inserted specified currency unit (e.g., “pesos”) and the credit amounts corresponding thereto are stored in the storage unit of the game controller **70**. Note that “storage” here is a concept that includes adding to the monetary amount and the credit amount of the currency information when specified currency information for the player to play the game has already been stored in the storage unit of the game controller **70**. This information may be stored in the storage unit of the PTS apparatus **700**.

On the other hand, when the currency unit of the newly inserted bill is different from the specified currency (for example, when “dollars” are inserted), the specified currency information resulting from the conversion from the inserted monetary amount in the inserted currency unit to the monetary amount in the specified currency unit (e.g., “pesos”) is stored in the storage unit of the game controller **70**. This conversion is executed in the PTS device **700**, and the conversion result is transmitted from the PTS device **700** to the game controller **70** and stored.

In this manner, when a bill is inserted into the bill entry **60**, the specified currency information for playing the game stored in the game controller **70** is updated based on the amount of the bill inserted at this time, and then the inputs of the 1-BET switch **34S**, the 2-BET switch **35S**, the 3-BET switch **36S**, the 5-BET switch **37S**, the 10-BET switch **38S**, the first credit switch **40S**, the second credit switch **41S**, the third credit switch **42S**, the fourth credit switch **43S**, the fifth credit switch **44S**, the spin switch **46S**, and the like are checked.

Next, the game controller **70** performs a symbol random determination process (S14). In this process, a symbol to be displayed in a region in the middle stage of the symbol display area **150** is determined as a to-be-stopped symbol from among a plurality of symbols arranged on the video reel. As a result, 15 symbols to be displayed in the symbol display area **150** (the upper stage region, the middle stage region, and the lower stage region) are determined.

The game controller **70** then stores the determined to-be-stopped symbol in a symbol storing area provided in the RAM.

Next, the game controller **70** performs an effect content determination process (S15). The game controller **70**

extracts an effect-use random number and determines one of a plurality of effect contents determined in advance by random determination.

Next, the game controller **70** performs a symbol display control process (S16). In this symbol display control process, scrolling of the video reel is started, and after a predetermined time has elapsed, the to-be-stopped symbol determined in the normal mode symbol random determination process of S14 are sequentially stopped in the middle stage of the symbol display area **150**. That is, 15 symbols including the to-be-stopped symbol are rearranged in the symbol display area **150**. That is, symbols corresponding to code numbers before and after the to-be-stopped symbol are rearranged in the upper and lower stages of the symbol display area **150**.

Next, the game controller **70** performs payout amount determination process (S17). In this process, on the basis of the symbol combination table stored in the RAM, it is determined whether or not a predetermined number of symbols of the same type are connected to the first to fifth array area and winning is established in the region which is the target of result determination by the WAYS BET of the symbol display area **150**. A privilege such as a payout or a right to execute a free game is awarded in accordance with the value of a winning or bet counter (i.e., the bet credit type). The awarded payout is stored in a payout amount storage area provided in the RAM.

Next, a payout process is performed (S18). The game controller **70** adds the value stored in the payout amount storage area to the value of the credit counter provided in the RAM. For example, when the player presses the CASHOUT button **32** of the control panel **30**, the detected CASHOUT switch (not shown) outputs a signal to the main CPU (not shown) of the game controller **70**, and the credit amount stored on the IC card stored in the IC card control unit **741** is updated to the value of the credit counter.

Further, coins may be discharged from the slot machine **10** based on input of the CASHOUT button **32**.

Next, the main CPU **1071** performs a game-end notification process (S19). This process is a process of transmitting data, indicating that one unit game has ended, to the PTS device **700**. The PTS device **700** transmits the data to a hall management server, and a random determination of a bonus game or the like is performed in response to the data. When the process of S19 ends, the routine returns to the process of S12, and the game unit is repeated.

#### A Bet Display Process for an Inserted Currency

FIG. **8** is a flowchart showing a bet display process for an inserted currency that is executed in the game controller **70**, the PTS device **700**, and the control panel **30** and the bill entry **60** of the of the slot machine **10**.

When a bill is inserted into the bill entry **60** (S60), the inserted currency information indicating the monetary amount in the currency unit of the inserted currency is transmitted from the bill entry **60** to the PTS device **700** (S61). The specified currency unit (e.g., "pesos") is set in advance in the game controller **70** of the slot machine **10**, and the PTS device **700** determines whether or not the currency unit of the inserted bill matches with the specified currency unit based on information indicating the type the specified currency unit that is stored in the RAM **753**. In this determination process, when it is determined that the information matches, the monetary amount information expressed in the specified currency unit is transmitted to the game controller **10** of the slot machine **10** as inserted

currency information (S63). On the contrary, when the currency unit of the inserted currency is determined to be different from the specified currency unit, the currency unit different from the particular currency units, based on the exchange rate stored in the RAM **753** of the PTS device **700** (see FIG. **6A**), the monetary amount information is converted to a monetary amount expressed in the specified currency unit, and information indicating the inserted currency unit, the information indicating the monetary amount in the currency unit before conversion (i.e., the currency unit of the inserted bill), and information indicating the monetary amount in the specified currency unit after conversion are transmitted to the game controller **70** of the slot machine **10** as inserted currency information (S63).

When only the information indicating the monetary amount expressed in the specified currency unit is transmitted from the PTS device **700**, the game controller **70** (which specifically refers to the CPU inside the game controller **70**) determines that the inserted currency unit is the specified currency unit, and updates credit data stored inside the game controller **70** by adding the inserted monetary amount to the credit data (S64). On the other hand, when information indicating a currency unit other than the specified currency unit and monetary amounts before and after conversion are transmitted from the PTS device **700**, the game controller **70** updates the credit data based on information indicating the currency unit and information of the monetary amounts before and after conversion (S64).

In this embodiment, the game controller **70**, "pesos" is stored (i.e., set) in advance in the storage unit as the specified currency unit, and the monetary amount information is stored as credit data when the specified currency is inserted. However, to the contrary, when a currency other than the specified currency unit is inserted, a set of information indicating the currency unit of the inserted currency (i.e., information indicating the type of currency unit, image data (i.e., symbols) for visually displaying the type), the monetary amount in the inserted currency unit, and the monetary amount resulting from converting the monetary amount in the inserted currency to the specified currency unit are stored as credit data.

That is, in the update and display process of the credit data (S64), when the currency of the specified currency unit is inserted, only information indicating the monetary amount in the specified currency unit and the corresponding credit amount information is stored as credit data, and when a currency other than the specified currency unit is inserted, information indicating the inserted currency unit, information indicating the monetary amount in the inserted currency unit, information indicating the monetary amount converted to the specified currency unit, and information indicating the credit amount corresponding to the monetary amount are stored as credit data, and, as a result, the player can understand the currency unit displayed by the game controller **70** when confirming the contents of the credit data.

That is, the game controller **70** checks the information stored as credit data, when the monetary amount information in the specified currency unit and the monetary amount information in a currency unit other than the specified currency unit (and information indicating the credit amounts corresponding to these monetary amount information) is stored as a set, it is possible to determine that currency other than the currency in the specified currency unit was inserted, and in this case, by displaying the monetary amount indicating the inserted currency unit other than the specified currency unit on the lower image display panel **141** (described later in FIGS. **9** and **10**), in contrast to internal

processing done with the monetary amount expressed in the specified currency unit stored as credit data, the amount to be displayed can be the monetary amount that has been converted to the inserted currency unit. Further, in this case, in addition to the monetary amount, displaying an image (i.e., a symbol) indicating the type of currency unit (i.e., a currency unit other than the specified currency unit), the player can be made to easily understand the currency unit associated with the monetary amount displayed. For example, when the currency unit of the inserted bill is “dollars”, that is, a currency unit other than the specified currency unit (e.g., “pesos”), a display of “\$10” is displayed. In other words, the currency unit can be indicated by displaying the symbol “\$”, which represents “dollars”, before the number. Note that an image (i.e., a symbol) representing the currency unit is not limited to this dollar sign, and, for example, an image that impressively represents a large “dollar” in another display frame (e.g., an image or the like that represents the national flag) may be used.

In contrast, if only the monetary amount expressed in the specified currency, as credit data, is stored, the game controller 70 displays the monetary amount in the specified currency unit on the lower image display panel 141.

Note that in the state in which a bill in a currency other than the specified currency is displayed in a currency unit other than the specified currency unit by being inserted, the game controller 70 that has received the inserted currency information (S63) from the PTS device 700 when a bill of the specified currency unit is newly inserted into the bill entry 60, in the credit data update and display process (S64), from among the monetary amount information in the specified currency unit which has been stored until then and the monetary amount information in a currency unit other than the specified currency unit, the monetary amount information in the currency unit other than the specified currency unit is deleted, and by limiting to the monetary amount information in the specified currency unit, the information that is to be displayed is determined to be the monetary amount information in the specified currency unit. Incidentally, regarding which currency to display in, dedicated information may be separately stored, as currency information to be displayed, in the storage unit of the game controller 70.

When credit data is updated in the game controller 70, the updated information is transmitted to the control panel 30 (S65). In the control panel 30, the display information stored in the display controller 170 is updated based on the updated information transmitted from the game controller 70 (S66). The display information is information for displaying bet amounts displayed on the display devices 40a, 41a, 42a, 43a, 44a of the control panel 30 (i.e., bet amounts assigned to each of the credit buttons 40, 41, 42, 43, 44) and is image data of specific text for displaying monetary credit amounts required to bet in the specified currency unit or the currency unit of the inserted currency which is different from the specified currency unit. For example, when the inserted currency is in the specified currency unit (e.g., “pesos”), the credit amount required to bet are displayed on each of the display devices 40a, 41a, 42a, 43a, 44a, along with the corresponding monetary amounts in the specified currency unit (e.g., “pesos”). On the other hand, when the currency unit of the inserted currency (e.g., “dollars”) is other than the specified currency unit, then the credit amount required to bet are displayed on each of the display devices 40a, 41a, 42a, 43a, 44a along with the corresponding monetary amounts in the currency unit of the inserted currency.

Display information (i.e., the bet amount table shown in FIGS. 6B and 6C) for performing this display is stored in the game controller 70, and by referring to this bet amount table, the game controller 70 selects information to be displayed on the display devices 40a, 41a, 42a, 43a, 44a of the control panel 30 (i.e., the number of bets required to start the game and the amount corresponding to the number of bets (i.e., the amount represented by the specified currency when the inserted currency is only a specified currency, and the amount represented by a currency unit of the inserted currency when the inserted currency is not the specified currency unit) and transmits it to the display controller 170. Based on this information, the display controller 170 displays the corresponding information on each of the display devices 40a, 41a, 42a, 43a, 44a of the control panel 30. The display controller 170 also controls the displays on the display devices 34a to 38a of the control panel 30. Thus, if the currency unit of the inserted bill is different from the currency inserted until that time, the update and display process of the credit data (S64) and the update and display process (S66) cause the monetary amounts (i.e., the currency unit) displayed on the display devices 40a, 41a, 42a, 43a, 44a of the control panel 30 to change.

In this manner, in the game controller 70, when credit data is updated in a state where the display is updated for each of the display devices on the control panel 30, and the player places a bet by operating the control panel 30 (S67), information from the control panel 30 indicating the bet information (i.e., the operation information) is transmitted to the game controller 70 (S68). In the game controller 70, in the credit data update and display process (S64), the credit amount and the monetary amount displayed on each of the display devices of the control panel 30 are stored, functions assigned to each of the buttons 34-38, 40-44 provided to each of the display devices are stored, and based on the operation information of the control panel 30 (i.e., information indicating the operated button), the bet amount and the corresponding monetary amount can be understood.

Thus, the game controller 70 that has received information from the control panel 30 indicating bet information displays the bet information to a section of the lower image display panel 141 of the slot machine 10 (S69). In this case, the game controller 70, based on the credit data (or currency information) stored in the storage unit, displays monetary bet amounts in the specified currency unit or a currency unit other than the specified currency unit on the lower image display panel 141. Specifically, when the currency unit of the currency inserted into the bill entry 60 is the specified currency unit, bet amounts are displayed in monetary amounts in the specified currency unit, and when the currency unit of the currency inserted into the bill entry 60 is a currency unit other than the specified currency unit, bet amounts are displayed in monetary units in the inserted currency unit.

The game controller 70 is configured to move the game forward (i.e., performing bets, calculating payouts, etc.) according to the monetary amounts expressed in the specified currency unit, and when the bet amount that is in a currency unit different from the specified currency unit is displayed in the lower image display panel 141, the game controller 70, based on the bet information from the control panel 30 (S68) (i.e., operation information of the buttons), obtains a bet amount in the specified currency unit and transmits the bet amount to the PTS device 700 as bet information (S70). In the PTS device 700, this bet amount is converted to a monetary amount in a currency unit other than the specified currency unit with the exchange rate shown in

FIG. 6A (S71), and the conversion result, as conversion result information, is transmitted to the game controller 70 (S72). Thus, when the player inputs a bet by operating the control panel 30, the game controller 70 displays the information related to the bet inputted (i.e., a bet amount in the currency unit of the inserted currency that is different from the specified currency unit), on a section of the lower image display panel 141 of the slot machine 10. Incidentally, the PTS device 700, in addition to the bet amount in the currency unit, by calculating the corresponding credit amount and transmitting the number to the game controller 70, the game controller 70 can also display the bet amount with the credit amount on the lower image display panel 141.

Note that information indicating the currency unit of the inserted currency, information of the monetary amounts displayed on the display devices 40a, 41a, 42a, 43a, 44a, and information for displaying images can be stored in various storage units such as the storage units of the PTS device 700, the display controller 170, and the game controller 70.

The conversion with the exchange rate may be performed by a device other than the PTS device 700, for example, the game controller 70, the control panel 30, or the like.

#### Display of Display Device

Information related to currency information and the like shown in FIG. 9 is displayed on the lower image display panel 141 of the slot machine 10.

In addition to the symbol display area 150, the lower image display panel 141 is provided with a denomination touch icon 201, a MENU touch icon 202, a volume touch icon 203, a CREDIT meter 204, a bet meter 205, a win meter 206, a game message display area 207, a free game play counter (FG counter) 208, a WAY number display area 209, an error log indicator area 210, a system message display area 211, a clock display area 212 (including an upper display switching icon), and a stock counter display area 214 at the time of re-triggering.

The denomination touch icon 201 displays a monetary amount (e.g., \$0.01) corresponding to one credit in the currency unit of the bill inserted into the bill entry 60 together with a currency symbol (e.g., a symbol indicating “dollars”) representing the currency unit of the inserted currency. By touching the denomination touch icon 201, the set monetary amount per credit can be changed. More specifically, when the currency unit of the inserted bill is “dollars”, the set monetary amount per credit can be changed to any one of five levels in the range of “\$0.01” to “\$10”. Every time the player touches the denomination touch icon 201, an instruction to change the setting to the content of “\$0.01”, “\$0.1”, “\$1.0”, “\$5.0”, or “\$10” is transmitted to the game controller 70, and the content of the setting is changed to the monetary amount per credit in the game controller 70, and the display of the denomination touch icon 201 is changed to the content of the changed setting by the game controller 70. As described above, the game controller 70 can store the currency unit of the inserted bill and display the monetary amount per credit in the currency unit on the denomination touch icon 201. As a result, the player can understand the amount per credit by displaying in the currency unit inserted by the player. When the currency unit of the bill inserted into the bill entry 60 is “pesos”, the game controller 70 switches the amount displayed on the denomination touch icon 201 and the symbol representing the currency unit to a notation representing “pesos”, for

example, as shown in FIG. 10A. Specifically, the monetary amount in “pesos” per credit is converted in the PTS device 700, and the conversion result is displayed on the denomination touch icon 201 by the game controller 70. In this display, a symbol for the currency unit “pesos”, shown by adding two horizontal lines to “P”, is added to the display. In this manner, the monetary amount per credit displayed on the denomination touch icon 201 is switched in accordance with the currency unit of the inserted currency.

In the present embodiment, the case has been described in which the switching of the denomination touch icon 201 can be changed to one of five levels in the range of “\$0.01” to “\$10”, but the present invention is not limited to this, and the range of the monetary amount and the number of levels can be variably set.

The MENU touch icon 202 is an icon for changing the content (e.g., the display language) to be displayed on the lower image display panel 141 as required. By touching this icon, a pop-up icon for selecting a language is displayed. When the player touches the icon, the selected content is transmitted to the game controller 70, and the game controller 70 displays display characters displayed on the lower image display panel 141 in the selected language. As a result, the player can select and display a desired language display. The selected result is transmitted from the game controller 60 to the display roller 170, whereby the display languages of the display devices 34a to 38a, 40a to 44a, and 47a of the control panel 30 can be switched to the selected language and displayed.

The volume touch icon 203 is a touch icon for changing the volume of sound or effect sound output from a speaker connected to the game controller 70. Each time this icon is touched, the volume can be selected in a cyclic manner such as small, medium, large, small, and so on.

The CREDIT meter 204 displays the sum total of the monetary amount inserted by the player into the slot machine 10 (i.e., the game controller 70) and the monetary amount awarded to the player as a result of a game in the currency unit of the bill inserted by the player into the bill entry 60. Specifically, when the currency unit of the bill inserted by the player is “dollars”, the PTS device 700 transmits the inserted currency information (i.e., the currency unit in “dollars” and the monetary amount thereof) from the bill entry 60 to the game controller 70 together with the specified currency information including the monetary amount in the specified currency unit (e.g., “pesos”) and the corresponding credit amount. The game controller 70 receives the information and displays the monetary amount on the CREDIT meter 204 in the currency unit (e.g., “dollars”) inserted by the player. In this case, the game controller 70 displays the symbol of the currency unit “dollar” together with the monetary amount based on the information representing the currency unit (e.g., “dollars”) of the inserted currency sent from the PTS device 700 (FIG. 9).

When the currency unit of the bill inserted into the bill entry 60 is “pesos”, the game controller 70 switches the monetary amount displayed on the CREDIT meter 204 and the symbol representing the currency unit to a symbol representing “pesos”, for example, as shown in FIG. 10A. More specifically, the PTS device 700 transmits the inserted currency information (i.e., the currency unit represented by “pesos” and the monetary amount thereof), transmitted from the bill entry 60, to the game controller 70 as specified currency information including the credit amount corresponding to the inserted currency information. The game controller 70 that receives the inserted currency information

displays the monetary amount on the CREDIT meter **204** in the currency unit “pesos” inserted by the player. For example, a symbol representing the currency unit “pesos”, shown by adding two horizontal lines to “P”, is added to the display. In this manner, the monetary amount displayed on the CREDIT meter **204** is switched in accordance with the currency unit of the inserted currency.

The player can bet on the games from the monetary amount displayed on the CREDIT meter **204**. For instance, the display example shown in FIG. 9 and FIG. 10A shows a case in which the display is in a currency unit inserted by the player, but in the present embodiment, the CREDIT meter **204** is configured by a touch icon, and the player can switch the monetary amount display shown in FIG. 9 to a display with the credit amount as shown in FIG. 10B, for example, by touching the CREDIT meter **204**. The display in terms of credit amount is a result obtained by converting the currency unit inserted by the player into the credit amount according to the rate at that time. Specifically, when the currency unit of the bill inserted by the player is “dollars”, the game controller **70** can display the inserted currency information transmitted from the PTS device **700** and the credit amount converted from the inserted amount (for example, the credit amount corresponding to 1 php=1 credit when “dollars” is converted to “pesos”) on the CREDIT meter **204** based on the result of conversion of the inserted currency information to the specified currency unit (e.g., “pesos”) and the specified currency information including the credit amount corresponding thereto.

Further, by touching the CREDIT meter **204**, the game controller **70** may be switched to display both the monetary amount expressed in the currency unit of the inserted bill and the corresponding credit amount, as shown in FIG. 10C.

The CREDIT meter **204** displays the monetary amount that is subtracted every time the player specifies a bet amount, and also displays the monetary amount that is added every time a payout is awarded as a result of a game.

The BET meter **205** displays the total bet amount for executing the game, which is specified by the player operating the control panel **30**. When the player specifies a bet amount by operating the control panel **30**, information representing the specified bet amount is transmitted from the control panel **30** to the PTS device **700**, and the bet amount, expressed in the currency unit of the inserted currency in the PTS device **700**, and the corresponding credit amount are calculated and transmitted from the PTS device **700** to the game controller **70**. The game controller **70** which has received these pieces of information displays, selectively, the bet amount specified by the player according to the amount in the inserted currency (e.g., “dollars”)(FIG. 9), the credit amount (FIG. 10B), or both (FIG. 10C). The game controller **70** displays the selection when the BET meter **205**, having a touch icon configuration, is touched. The game controller **70** adds bet amounts until the player finishes the game and exhausts his/her credits, thereby displaying the bet amount displayed on the BET meter **205** as the total amount until the game is finished and not for each game. The BET meter **205** is updated each time a game is played.

Note that the BET meter **205** shown in FIG. 9 shows a case in which the currency unit of the bill inserted into the bill entry **60** is “dollar”, but when the currency unit of the bill inserted into the bill entry **60** is “pesos”, the game controller **70** is switched to a notation with a symbol (e.g., a symbol obtained by adding two horizontal lines to “P”) representing the monetary amount in “pesos” and the currency unit thereof as shown in FIG. 10A, for example, based

on the monetary amount data in the currency unit of “pesos” obtained from the PTS device **700**.

The WIN meter **206** displays the amount of the payout (i.e., the prize) to be awarded to the player based on the game results, and when the payout occurs as an execution result, the game controller **70** selectively displays the monetary amount according to the monetary amount of the inserted currency (e.g., “dollars”) (see FIG. 9), the credit amount (FIG. 10B), or both thereof (FIG. 10C). This selection is displayed by touching the WIN meter **206** having a touch icon configuration.

Note that the WIN meter **206** shown in FIG. 9 indicates the case where the currency unit of the bill inserted into the bill entry **60** is “dollars”, but when the currency unit of the bill input to the bill entry **60** is “pesos”, the game controller **70** is switched to the notation by the symbol (e.g., the symbol obtained by adding two horizontal lines to “P”) indicating the monetary amount in pesos and the currency unit thereof as shown in FIG. 10A, for example, based on the monetary amount data in the currency unit of pesos obtained from the PTS device **700**.

The game message display area **207** displays a description of the game contents and the like in the form of sentences. The free game play counter (FG counter) **208** displays the number of free game plays. The WAY display area **209** displays the type of WAYS BET specified by the player operating the control panel **30** in the form of characters or the like. The error log indicator area **210** is an area for an error log indicator related to the execution of the game. The system message display area **211** is an area for displaying various messages such as payment, ticket history, communication information, and the like. The upper display switching button **212** is a touch-icon area for switching the display content of the upper image display panel **131**. The stock counter **214** at the time of re-triggering indicates the number of remaining features at the time of re-triggering.

#### Other Embodiments

In the embodiment described above, a case where a bill is used as a gaming medium (i.e., paper stock) has been described, but the present invention is not limited to this, and, for example, coins, medals, tokens, tickets with bar codes, and the like can be applied in addition to electronic value information such as cyber money. Further, the currency unit is not limited to “pesos” or “dollars”, and a variety of currency units are permissible.

In the embodiment described above, a case where the conversion between the currency unit of the inserted bill and the specified currency unit set in the slot machine **10** is performed in the PTS device **700** has been described, but the conversion is not limited to this, and may be performed in another device such as the game controller **70**, for example.

In the embodiment described above, the present invention is applied to the slot machine **10**, but the present invention is not limited to this, and can be widely applied to other gaming machines as well as other machines such as vending machines for beverages and the like. When the present invention is applied to a vending machine for beverages or the like, when a user inserts currency of a currency unit other than the specified currency unit into the vending machine, the control unit of the vending machine converts the inserted currency into the specified currency unit and then executes a selling process in the specified currency unit. The sales process refers to a process of deducting the price of a commodity specified by the player by operating the push buttons or the like from the monetary amount inserted and

paying out the remaining amount as change. In this case, the control unit displays not the specified currency unit for which the sales process has been performed, but the result of converting from the specified currency unit to the currency unit which the user has inserted so that the user can see the display in his/her familiar currency unit and can easily understand the amount.

In the embodiment described above, the display control of the credit data (i.e., data such as the bet amount, the credit amount inserted by the player, etc.) on the control panel 30 or the lower image display panel 141 is performed by the game controller 70, but the present invention is not limited to this, and for example, the PTS device 700 or the like may perform the display control.

Thus, it is seen that the objects of the present invention are efficiently obtained, although it should be readily apparent to those having ordinary skill in the art that changes and modifications can be made to the invention without departing from the spirit and scope of the invention as claimed. Hence, it should be appreciated that variations of the information processing apparatus may be made, used and sold, and yet be within the spirit and scope of the claims.

Thus, it is seen that the objects of the present invention are efficiently obtained, although modifications and changes to the invention should be readily apparent to those having ordinary skill in the art, and these modifications are intended to be within the spirit and scope of the invention as claimed.

PARTS LIST

- 10 Slot machine
- 30 Control panel
- 60 Bill entry
- 70 Game controller
- 141 Lower image display panel
- 170 Display controller
- 700 PTS device

What is claimed is:

1. An information processing apparatus executable upon receipt of a medium of exchange associated with a national currency, comprising:

- a control device that executes a process based on first initial preset national currency information that includes a national currency unit;
- a display device that displays progress of the process of the control device;
- an input device configured to start the process;
- a medium of exchange accepting apparatus configured to receive and validate a medium of exchange including at least one of a bill, a ticket, a coin, a token, a magnetic card, an IC card, and electronic data, the received and validated medium of exchange including national currency information;

wherein the control device is further configured to:

- (a) upon receiving and validating a received medium of exchange that corresponds to the first initial preset national currency information to execute the process, displaying to the display device that the received medium of exchange corresponds to the first initial preset national currency information, displaying a first credit amount available according to the first initial preset national currency information, and displaying a relationship between an amount of the first initial present national currency and a first amount of credits required to execute the process, allowing execution of the process based on the first initial preset national

currency information, and displaying progress of the process according to the first initial preset national currency information, and

- (b) upon receiving and validating a received medium of exchange that does not correspond to the first initial preset national currency information to execute the process, automatically converting the first initial preset national currency information to execute the process to second other national currency information corresponding to the received medium of exchange, displaying to the display device that the received medium of exchange corresponds to the second other national currency information, displaying a second credit amount available according to the second other national currency information, and displaying a relationship between an amount of the second other national currency and a second amount of credits required to execute the process, allowing execution of the process based on the second other national currency information, and displaying progress of the process according to the second other national currency information; and, wherein upon receiving and validating a received medium of exchange that does not correspond to the first initial preset national currency information to execute the process and the control device displays progress of the process according to the second other national currency information, execution of the process by the control device is performed according to the first initial preset national currency information.

2. The information processing apparatus of claim 1, wherein the information processing apparatus is a slot-type gaming machine, and the input device has a second display device that displays a bet amount necessary for starting the process as well as currency information corresponding to the bet amount, and

the control device, based on the bet amount and the currency information derived from the received medium of exchange, performs a control process for displaying either the first initial preset national currency information corresponding to the bet amount or the second other national currency information corresponding to the bet amount on the second display device.

3. The information processing apparatus of claim 1, wherein the medium of exchange accepting apparatus is configured to transmit and receive electronic data to/from a settlement interface.

4. The information processing device of claim 3, wherein the settlement interface is configured for communication with a non-transitory computer readable storage device that stores information corresponding to a user.

5. The information processing apparatus of claim 1, further comprising an input device allowing a user to select to execute the process based on the first initial preset national currency information, the second other currency information, or a further other currency information.

6. The information processing apparatus of claim 5, wherein the information processing apparatus is a slot-type gaming machine further comprising a further input device allowing a user to select to execute a game based on the first initial preset national currency information, the second other national currency information, or a further other national currency information.

7. The information processing apparatus of claim 6, wherein upon receiving an award as a result of execution of the game, the award is dispensed in a predefined national currency.

23

8. The information processing apparatus of claim 6, wherein upon receiving an award as a result of execution of the game, the award is dispensed in a national currency corresponding to the national currency information derived from the received medium of exchange.

9. The information processing apparatus of claim 6, wherein upon receiving an award as a result of execution of the game, the award is dispensed in a user definable national currency.

10. The information processing apparatus of claim 1, wherein the information processing apparatus is a vending-type machine that displays the first initial preset national currency information including a national currency type and amount necessary for executing the process, and

the control device, based on the national currency information derived from the received medium of exchange, performs a control process to display either the first initial preset currency national information corresponding to the received medium of exchange, or the second other national currency information corresponding to received medium of exchange.

11. The information processing apparatus of claim 1, wherein when a first execution and display of the process based on the second other national currency information is completed and a medium of exchange corresponding to the first initial preset national currency information is subsequently received and validated, ceasing display of the second other national currency information and allowing a second execution and display of the process based on the first initial preset national currency information, and displaying progress of the process according to the first initial preset national currency information.

12. The information processing apparatus of claim 1, wherein upon receiving and validating a received medium of exchange corresponding to a national currency, the display device displays a relationship between the received national currency and an amount of credits required to execute the process.

13. The information processing apparatus of claim 12, wherein upon receiving and validating a received medium of exchange corresponding to the second other national currency,

the medium of exchange accepting apparatus obtains the second other national currency information including: a type of the second other national currency, a monetary amount of the second other national currency, information indicating a monetary amount of the second other national currency converted into the first initial preset national currency, and information indicating a credit amount corresponding to the monetary amount of the second other national currency, and transmits the second other national currency information as credit data to the control device;

the display device displays a credit amount of the second other national currency required to execute the process; and,

the control device, upon execution of the input device, obtains credit amount information of the first initial preset national currency required to execute the process, executes the process according to the first initial preset national currency, and displays progress of the process according to the second other national currency information.

14. The information processing apparatus of claim 13, wherein the input device displays the credit amount of the second other national currency required to execute the process; and,

24

the control device, upon execution of the input device displaying the credit amount of the second other national currency required to execute the process, obtains credit amount information of the first initial preset national currency required to execute the process, executes the process according to the first initial preset national currency, and displays progress of the process according to the second other national currency information.

15. An information processing apparatus executable upon receipt of a medium of exchange associated with a currency, comprising:

a control device that executes a process based on first initial preset currency information that includes a currency unit;

a display device that displays progress of the process of the control device;

an input device configured to start the process;

a medium of exchange accepting apparatus configured to receive and validate a medium of exchange including at least one of a bill, a ticket, a coin, a token, a magnetic card, an IC card, and electronic data, the received and validated medium of exchange including currency information;

wherein the control device is further configured to:

(a) upon receiving and validating a received medium of exchange that corresponds to the first initial preset currency information to execute the process, displaying to the display device that the received medium of exchange corresponds to the first initial preset currency information, displaying a first credit amount available according to the first initial preset currency information, and displaying a relationship between an amount of the first initial present currency and a first amount of credits required to execute the process, allowing execution of the process based on the first initial preset currency information, and displaying progress of the process according to the first initial preset currency information, and

(b) upon receiving and validating a received medium of exchange that does not correspond to the first initial preset currency information to execute the process, automatically converting the first initial preset currency information to execute the process to second other national currency information corresponding to the received medium of exchange, displaying to the display device that the received medium of exchange corresponds to the second other currency information, displaying a second credit amount available according to the second other currency information, and displaying a relationship between an amount of the second other currency information and a second amount of credits required to execute the process, allowing execution of the process based on the second other currency information, and displaying progress of the process according to the second other currency information;

wherein upon receiving and validating a received medium of exchange corresponding to the second other currency information,

the medium of exchange accepting apparatus obtains the second other currency information including: a type of the second other currency, a monetary amount of the second other currency, information indicating a monetary amount of the second other currency converted into the first initial preset currency, and information indicating a credit amount corresponding to the monetary amount of the second



other currency, and transmits the second other currency information as credit data to the control device;

the display device displays a credit amount of the second other currency required to execute the process; and,

the control device, upon execution of the input device, obtains a credit amount of the first initial preset currency required to execute the process, executes the process according to the first initial preset national currency, and displays progress of the process according to the second other national currency information.

16. The information processing apparatus of claim 15, wherein the input device displays the credit amount of the second other currency required to execute the process.

17. The information processing apparatus of claim 15, wherein when a first execution and display of the process based on the second other currency information is completed and a medium of exchange corresponding to the first initial preset currency information is subsequently received and validated, ceasing display of the second other currency information and allowing a second execution and display of the process based on the first initial preset currency information, and displaying progress of the process according to the first initial preset currency information.

\* \* \* \* \*