



US010653584B2

(12) **United States Patent**
Brady et al.

(10) **Patent No.:** **US 10,653,584 B2**

(45) **Date of Patent:** **May 19, 2020**

(54) **TABLET AND CAPSULE DISPENSING ASSEMBLY**

(71) Applicant: **Pill Development Group, LLC**, Sarasota, FL (US)

(72) Inventors: **Robert Owen Brady**, Sarasota, FL (US); **Joseph B. Bujalski**, Advance, NC (US); **Jeffery S. Heitzenrater**, Spencerport, NY (US); **Matthew William Vergin**, St. Petersburg, FL (US); **Jon Colin Leonard**, Sarasota, FL (US); **Joel Raymond Chartier**, Bradenton, FL (US)

(73) Assignee: **Pill Development Group, LLC**, Sarasota, FL (US)

(*) Notice: Subject to any disclaimer, the term of this patent is extended or adjusted under 35 U.S.C. 154(b) by 0 days.

(21) Appl. No.: **16/053,393**

(22) Filed: **Aug. 2, 2018**

(65) **Prior Publication Data**
US 2018/0344575 A1 Dec. 6, 2018

Related U.S. Application Data
(63) Continuation of application No. PCT/US2017/069049, filed on Dec. 29, 2017.
(Continued)

(51) **Int. Cl.**
A61J 7/04 (2006.01)
A61J 7/00 (2006.01)
(Continued)

(52) **U.S. Cl.**
CPC **A61J 7/0472** (2013.01); **A61J 1/035** (2013.01); **A61J 7/0076** (2013.01); **A61J 7/0084** (2013.01);
(Continued)

(58) **Field of Classification Search**
CPC A61J 1/035; A61J 7/0076; A61J 7/0084; A61J 7/0418; A61J 7/0445; A61J 7/0472;
(Continued)

(56) **References Cited**
U.S. PATENT DOCUMENTS
3,722,739 A * 3/1973 Blumberg B65D 83/0454 116/308
4,047,635 A * 9/1977 Bennett, Jr. A61J 7/0481 221/5
(Continued)

FOREIGN PATENT DOCUMENTS
GB 1277163 A * 6/1972 A61J 7/04
GB 1277163 A 6/1972
Primary Examiner — Gene O Crawford
Assistant Examiner — Kelvin L Randall, Jr.
(74) *Attorney, Agent, or Firm* — Simpson & Simpson, PLLC

(57) **ABSTRACT**
A dispensing assembly which includes a case having a superior component and inferior component, the superior component and inferior component operatively arranged to form a first cavity therebetween. A tablet disc is arranged within the first cavity having a plurality of tablets disposed about a circumference of the tablet disc, where the tablet disc is arranged to rotate about a central axis and within the case. The assembly further includes a lock to prevent rotation of the tablet disc in a first rotational direction during a first predetermined time interval. The lock includes a first component and a second component. The first component includes a display and a first circuit connected to the display. The second component includes an actuator, a catch, a plurality of teeth on an outer circumferential surface of the second component, and a ratchet operatively arranged to engage with the plurality of teeth and the case.

8 Claims, 13 Drawing Sheets

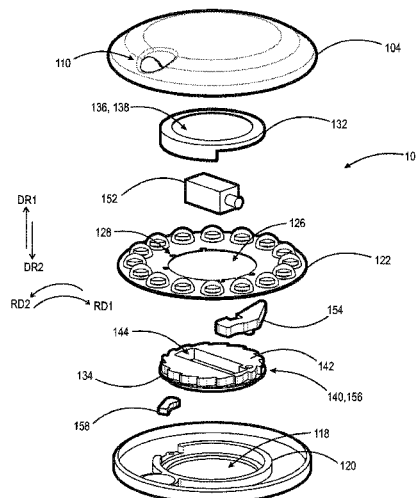

Related U.S. Application Data						
		9,492,357	B2 *	11/2016	MacVittie	A61J 7/0472
		10,073,955	B2 *	9/2018	Ervin	G06F 19/3462
(60)	Provisional application No. 62/440,569, filed on Dec. 30, 2016.	2002/0026330	A1	2/2002	Klein	
		2003/0050731	A1	3/2003	Rosenblum	
		2003/0086338	A1	5/2003	Sastry et al.	
		2003/0127463	A1	7/2003	Varis	
(51)	Int. Cl.	2003/0174554	A1	9/2003	Dunstone et al.	
	A61J 1/03 (2006.01)	2003/0183226	A1	10/2003	Brand et al.	
	B65D 83/04 (2006.01)	2003/0209558	A1 *	11/2003	Cross	B65D 83/0463
	A61J 7/02 (2006.01)					221/25
(52)	U.S. Cl.	2004/0172163	A1	9/2004	Varis	
	CPC	2004/0215369	A1	10/2004	Rosenblum	
	A61J 7/0418 (2015.05); A61J 7/0445 (2015.05); A61J 7/0481 (2013.01); B65D 83/0409 (2013.01); A61J 7/02 (2013.01); A61J 2200/30 (2013.01); A61J 2200/70 (2013.01); A61J 2205/10 (2013.01)	2005/0049746	A1	3/2005	Rosenblum	
		2006/0180600	A1	8/2006	Talyor	
		2006/0218014	A1	9/2006	Walker et al.	
		2006/0218015	A1	9/2006	Walker et al.	
		2007/0073560	A1	3/2007	Walker et al.	
		2007/0156282	A1	7/2007	Dunn	
		2007/0163583	A1	7/2007	Brand et al.	
(58)	Field of Classification Search	2007/0260491	A1	11/2007	Palmer et al.	
	CPC .. A61J 7/0481; A61J 2200/30; A61J 2200/70; A61J 2205/10	2007/0271001	A1	11/2007	Ratnakar	
	See application file for complete search history.	2007/0293982	A1	12/2007	Rosenblum	
		2008/0030309	A1	2/2008	Darrouzet	
		2008/0077440	A1	3/2008	Doron	
(56)	References Cited	2008/0210701	A1	9/2008	Cooper	
	U.S. PATENT DOCUMENTS	2008/0283542	A1	11/2008	Lanka et al.	
		2009/0048712	A1	2/2009	Rosenblum	
		2009/0164238	A1	6/2009	Auchinleck	
		2009/0294521	A1	12/2009	de la Huerga	
		2010/0100237	A1	4/2010	Ratnakar	
		2010/0228141	A1	9/2010	Kountotsis	
		2010/0318218	A1	12/2010	Muncy, Jr. et al.	
		2010/0324728	A1	12/2010	Rosenblum	
		2011/0036803	A1	2/2011	Mejia et al.	
		2011/0060457	A1	3/2011	De Vrught et al.	
		2011/0125317	A1	5/2011	Dunn	
		2011/0125318	A1	5/2011	Dunn	
		2011/0166700	A1	7/2011	Dunn	
		2011/0270442	A1	11/2011	Conley et al.	
		2012/0003928	A1	1/2012	Geboers et al.	
		2012/0006700	A1	1/2012	Geboers et al.	
		2012/0065776	A1	3/2012	Czaja et al.	
		2012/0089249	A1	4/2012	Rosenblum	
		2012/0101630	A1	4/2012	Daya et al.	
		2012/0165975	A1	6/2012	Yi et al.	
		2013/0088328	A1	4/2013	DiMartino et al.	
		2013/0090594	A1	4/2013	Palmer et al.	
		2013/0110283	A1 *	5/2013	Baarman	A61J 7/0084
						700/236
		2013/0134180	A1	5/2013	Cheyene	
		2013/0166066	A1	6/2013	Dunn	
		2013/0197693	A1	8/2013	Kamen et al.	
		2013/0256331	A1	10/2013	Giraud et al.	
		2013/0261794	A1	10/2013	Fauci	
		2013/0304255	A1	11/2013	Ratnakar	
		2013/0317645	A1	11/2013	Daya et al.	
		2014/0052468	A1	2/2014	Burrows et al.	
		2014/0058559	A1	2/2014	Haynes	
		2014/0207278	A1	7/2014	Czaja et al.	
		2014/0214200	A1	7/2014	Chrusciel et al.	
		2014/0239062	A1	8/2014	Nurse et al.	
		2014/0244031	A1	8/2014	Macoviak et al.	
		2014/0263425	A1	9/2014	Akdogan et al.	
		2014/0277705	A1	9/2014	Czaja et al.	
		2014/0277707	A1	9/2014	Akdogan et al.	
		2014/0324216	A1	10/2014	Beg et al.	
		2014/0326744	A1	11/2014	Ratnakar	
		2014/0339248	A1 *	11/2014	Reddy	A61J 7/0076
						221/1
		2014/0339249	A1	11/2014	Reddy et al.	
		2014/0346186	A1	11/2014	Reddy et al.	
		2014/0372144	A1	12/2014	Sterns et al.	
		2015/0025679	A1	1/2015	Rosenblum	
		2015/0048101	A1	2/2015	Reddy et al.	
		2015/0061832	A1	3/2015	Pavlovic et al.	
		2015/0145672	A1	5/2015	Chu	
		2015/0161558	A1	6/2015	Gitchell et al.	
		2015/0254427	A1	9/2015	Burrows et al.	
		2015/0272825	A1	10/2015	Lim et al.	

(56)

References Cited

U.S. PATENT DOCUMENTS

2015/0294551	A1	10/2015	Edwards et al.	
2015/0310185	A1	10/2015	Shah	
2015/0310186	A1	10/2015	Conley et al.	
2015/0317455	A1	11/2015	Lehmann et al.	
2015/0343144	A1	12/2015	Altschul et al.	
2015/0360834	A1	12/2015	Mikhail	
2016/0008227	A1*	1/2016	Foshee	A61J 7/0076 222/95
2016/0031620	A1	2/2016	Rosenquist	
2016/0081882	A1	3/2016	Joyce et al.	
2016/0085938	A1	3/2016	Hans	
2016/0128906	A1*	5/2016	Baarman	A61J 7/0084 221/2
2016/0158107	A1	6/2016	Dvorak et al.	
2016/0203292	A1	7/2016	Kamen et al.	
2016/0247345	A1	8/2016	Ratnakar	
2018/0064608	A1*	3/2018	Hines	A61J 7/0084
2018/0064609	A1*	3/2018	Hines	G16H 40/63

* cited by examiner

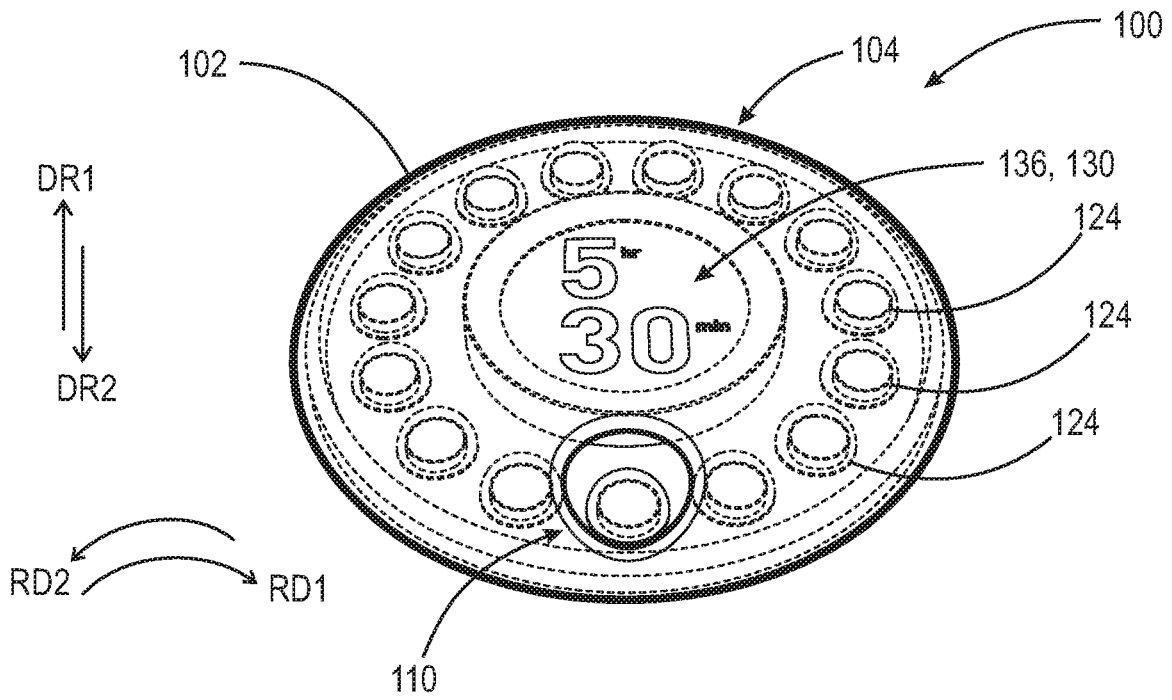

Fig. 1A

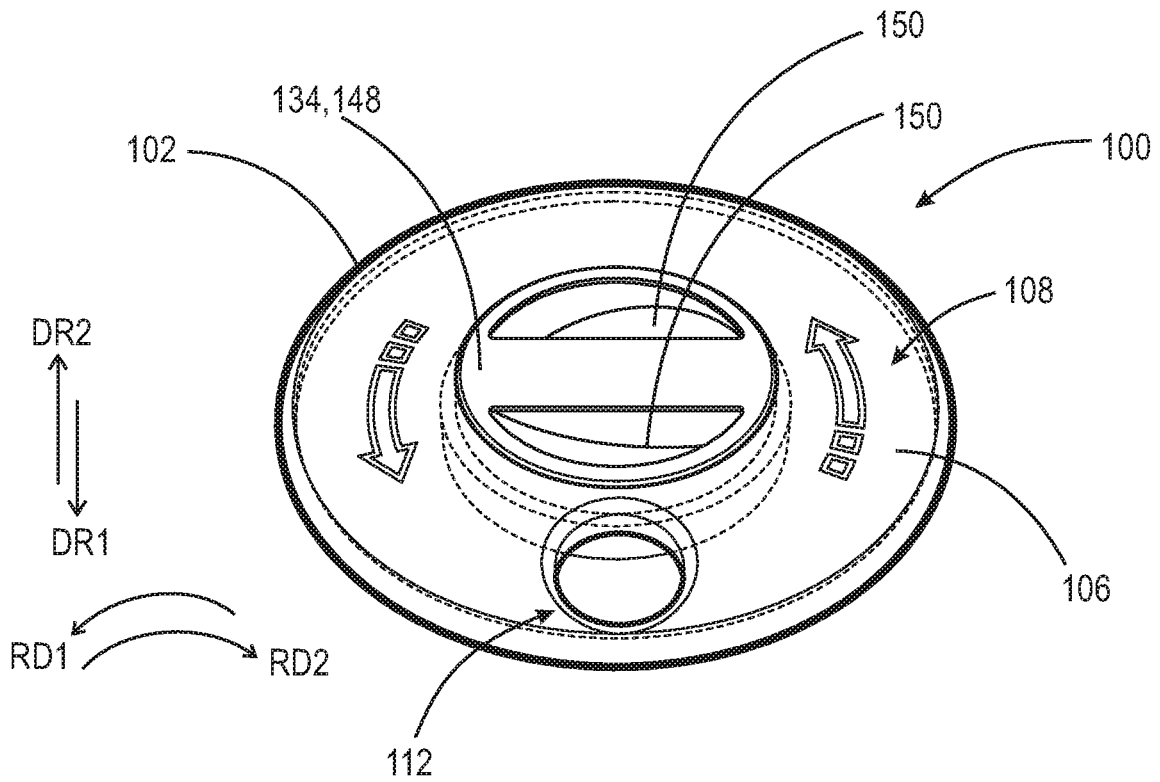

Fig. 1B

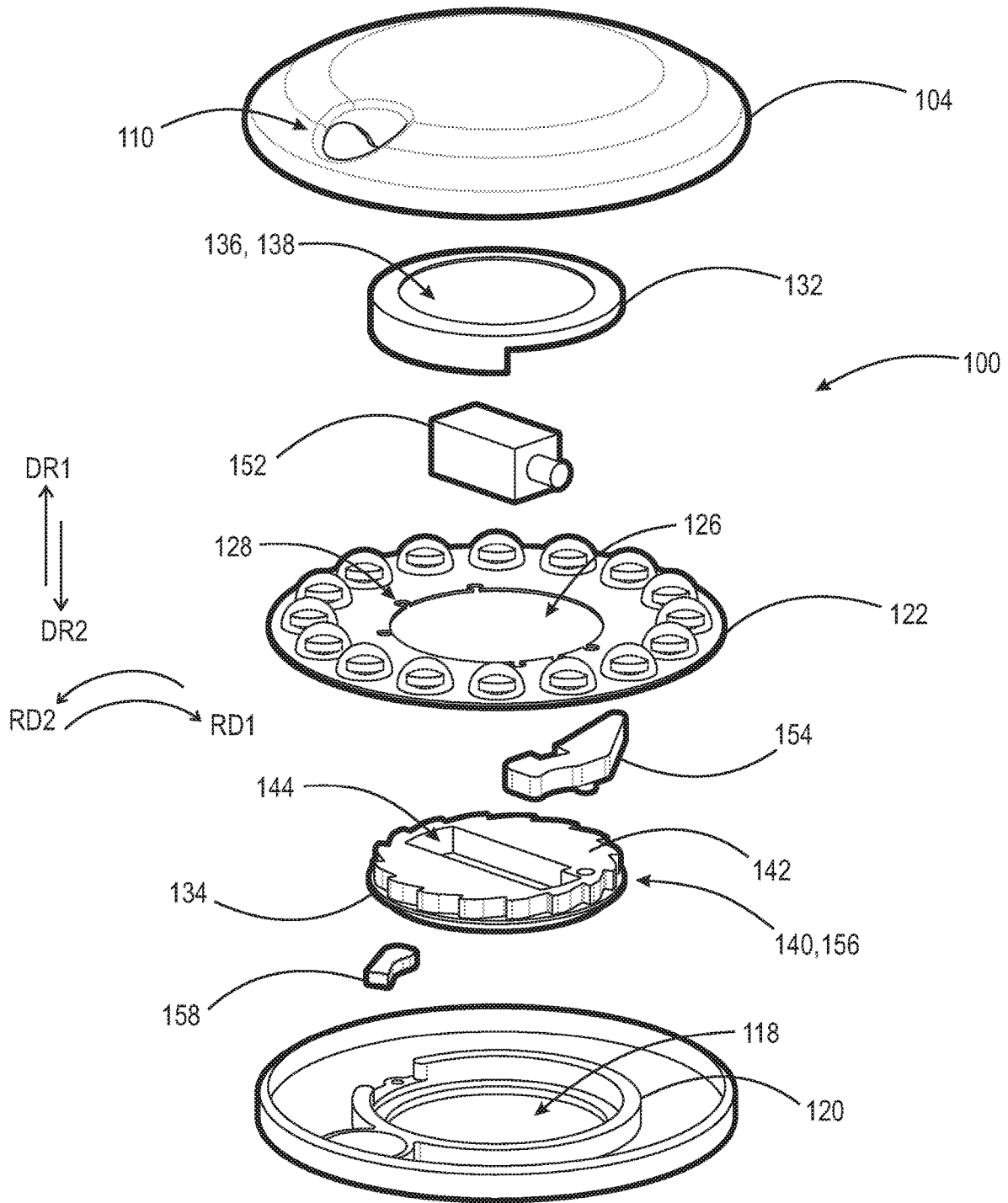

Fig. 2A

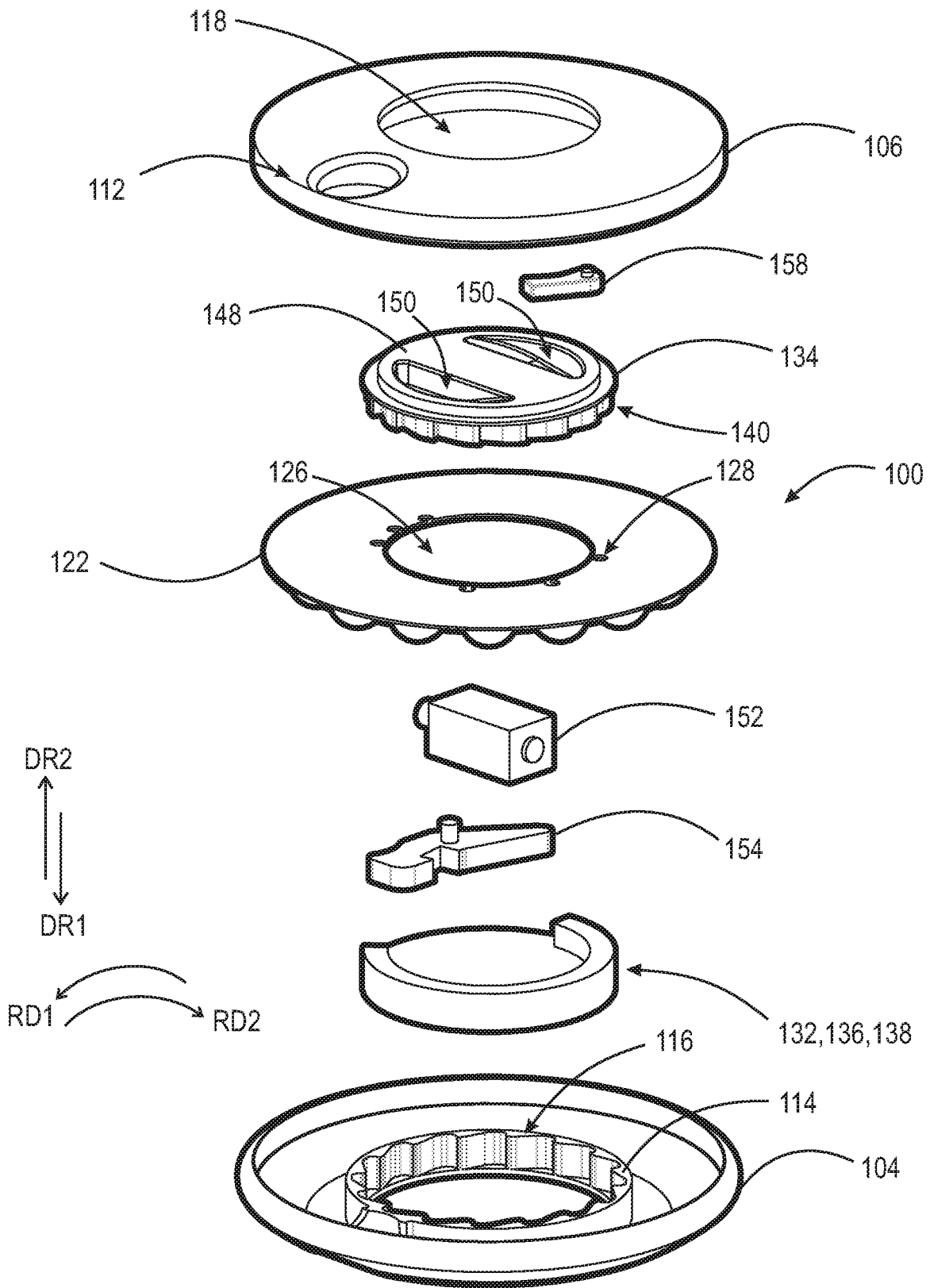

Fig. 2B

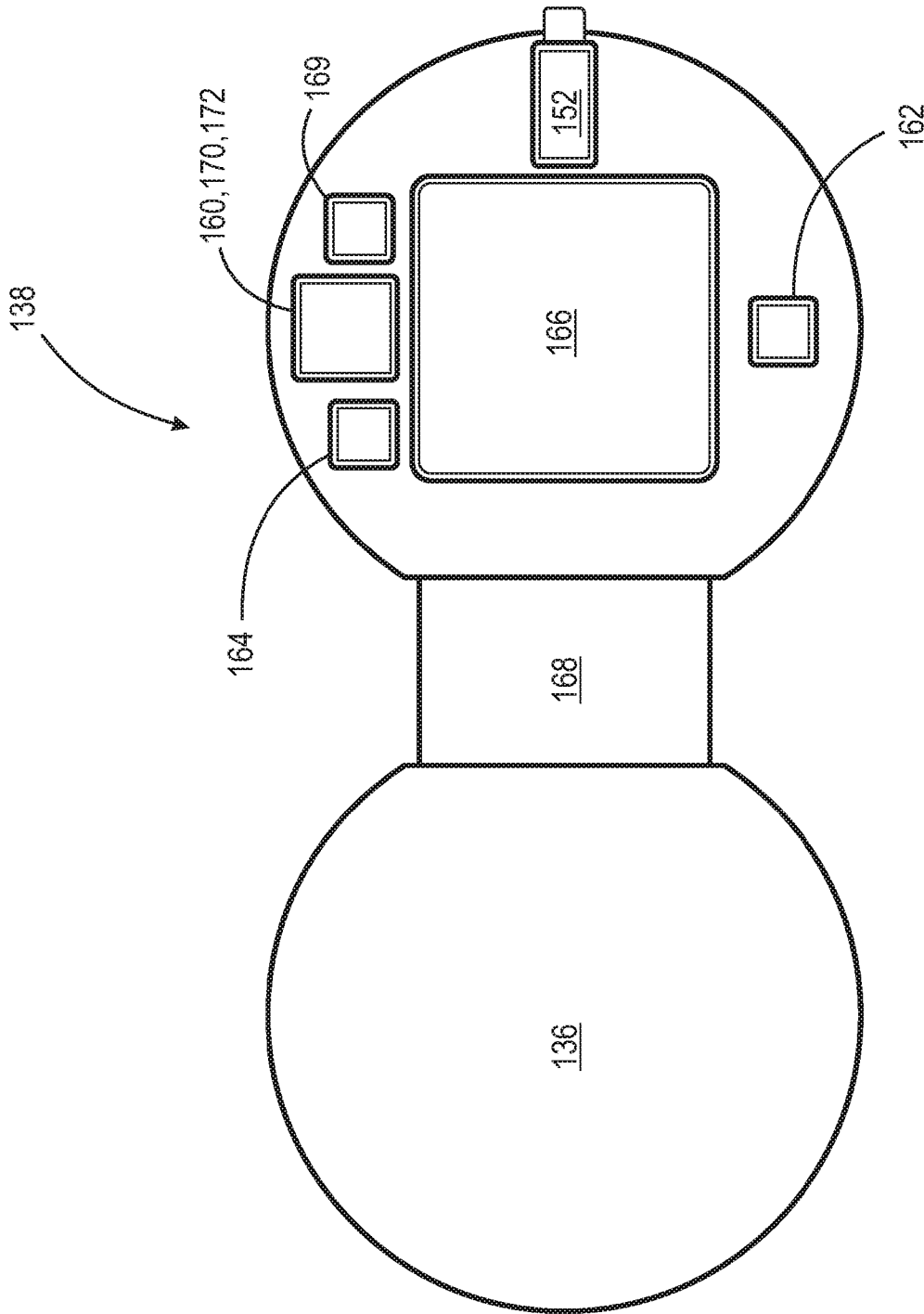

Fig. 3

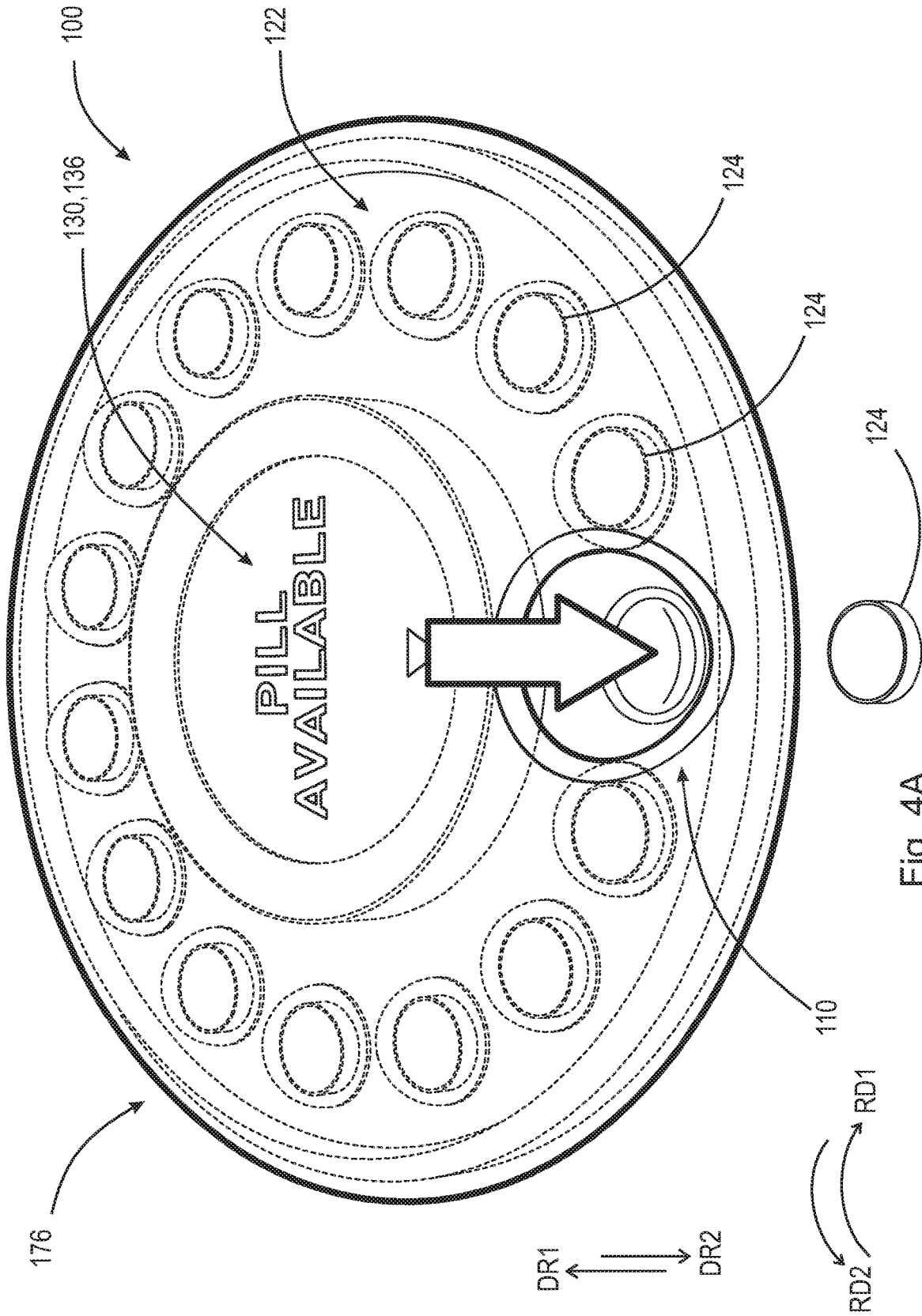

Fig. 4A

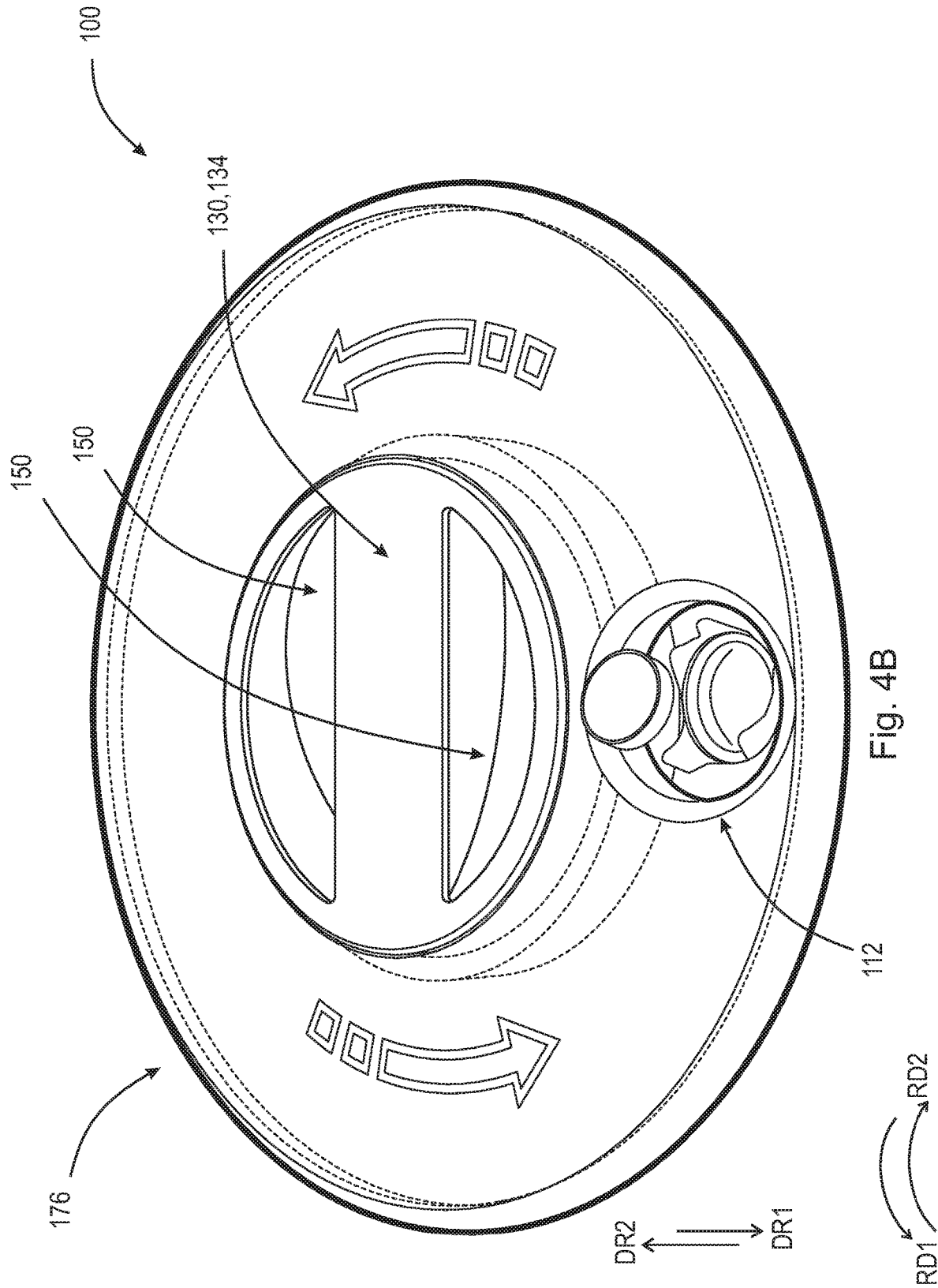
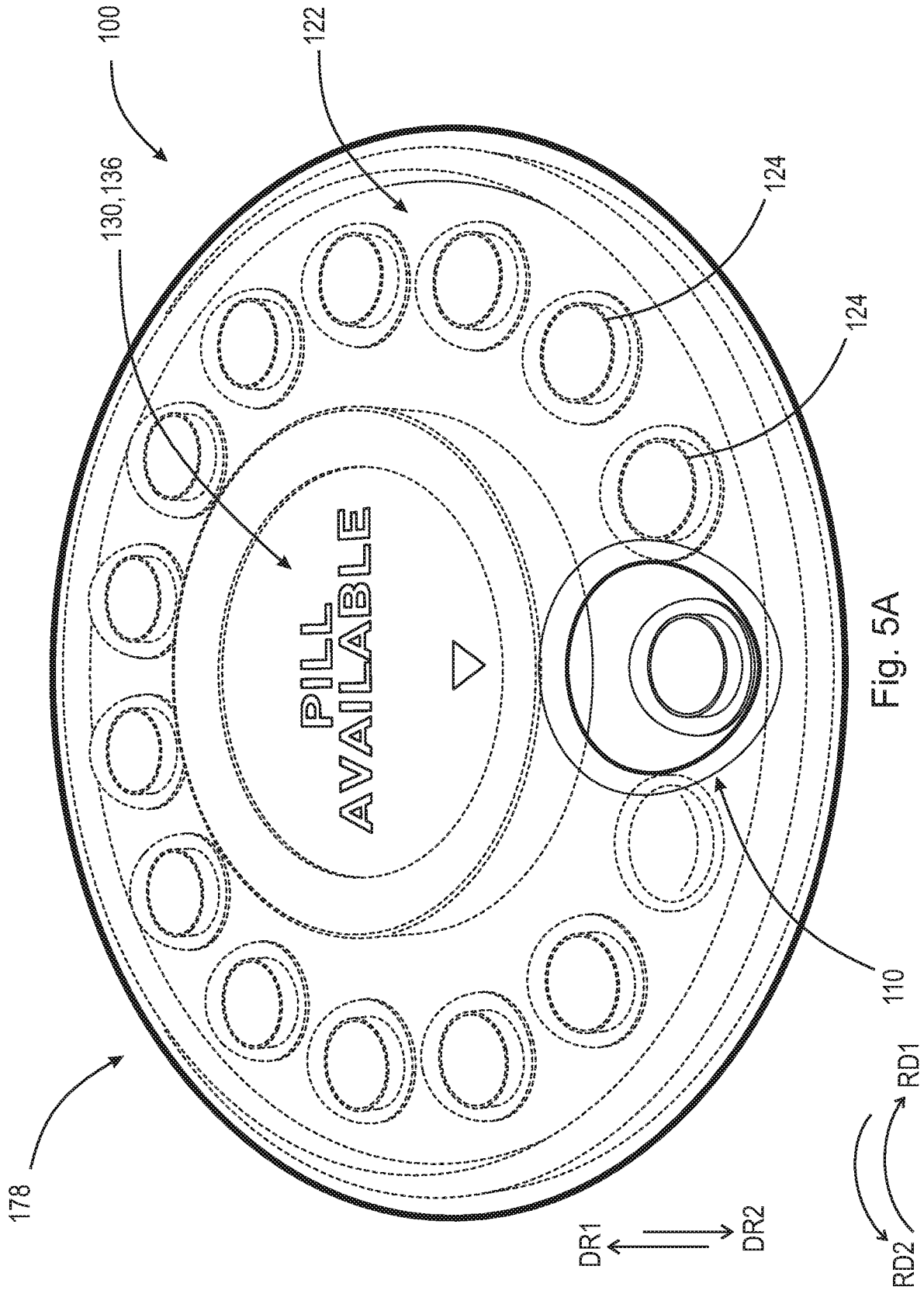

Fig. 4B



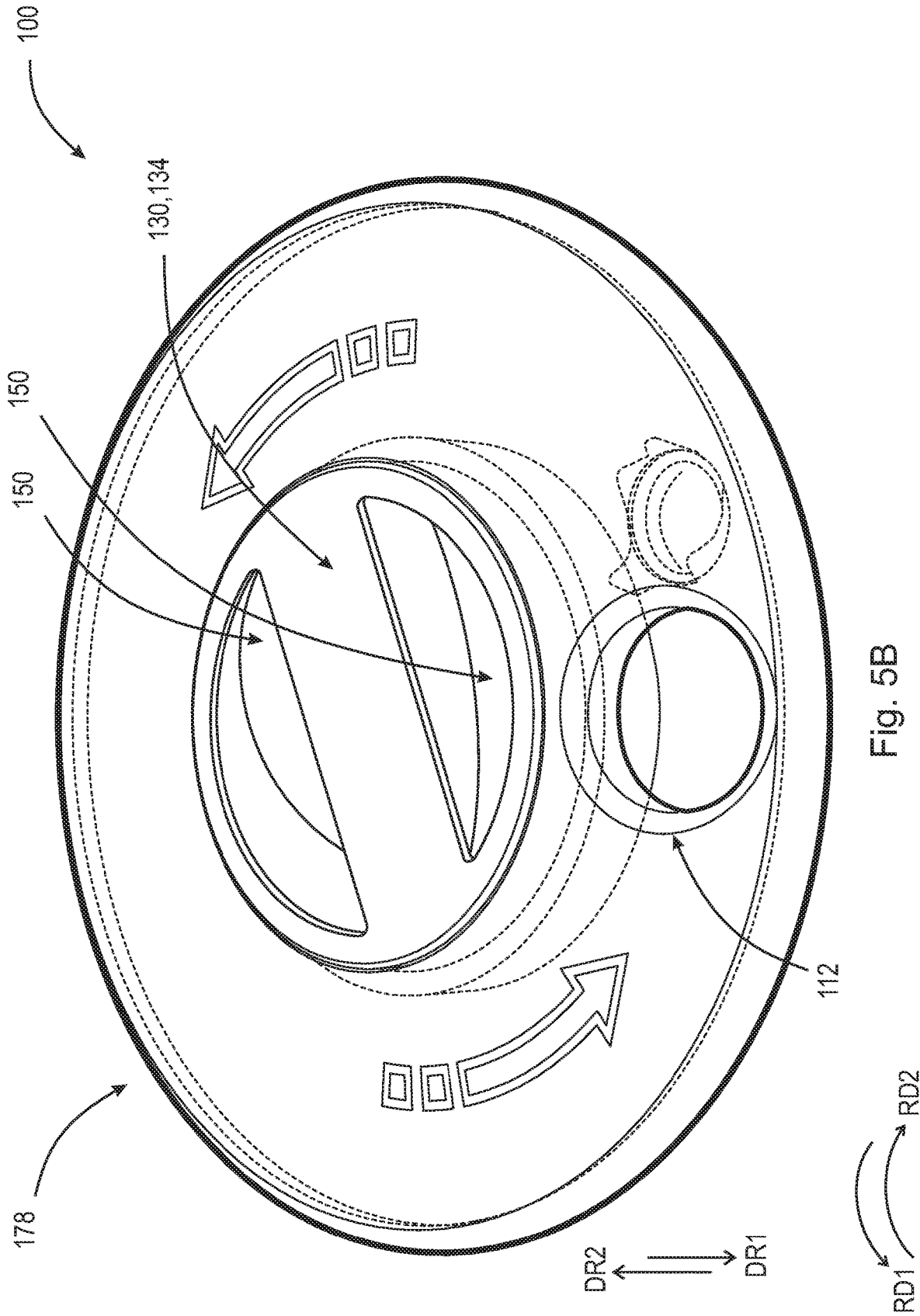
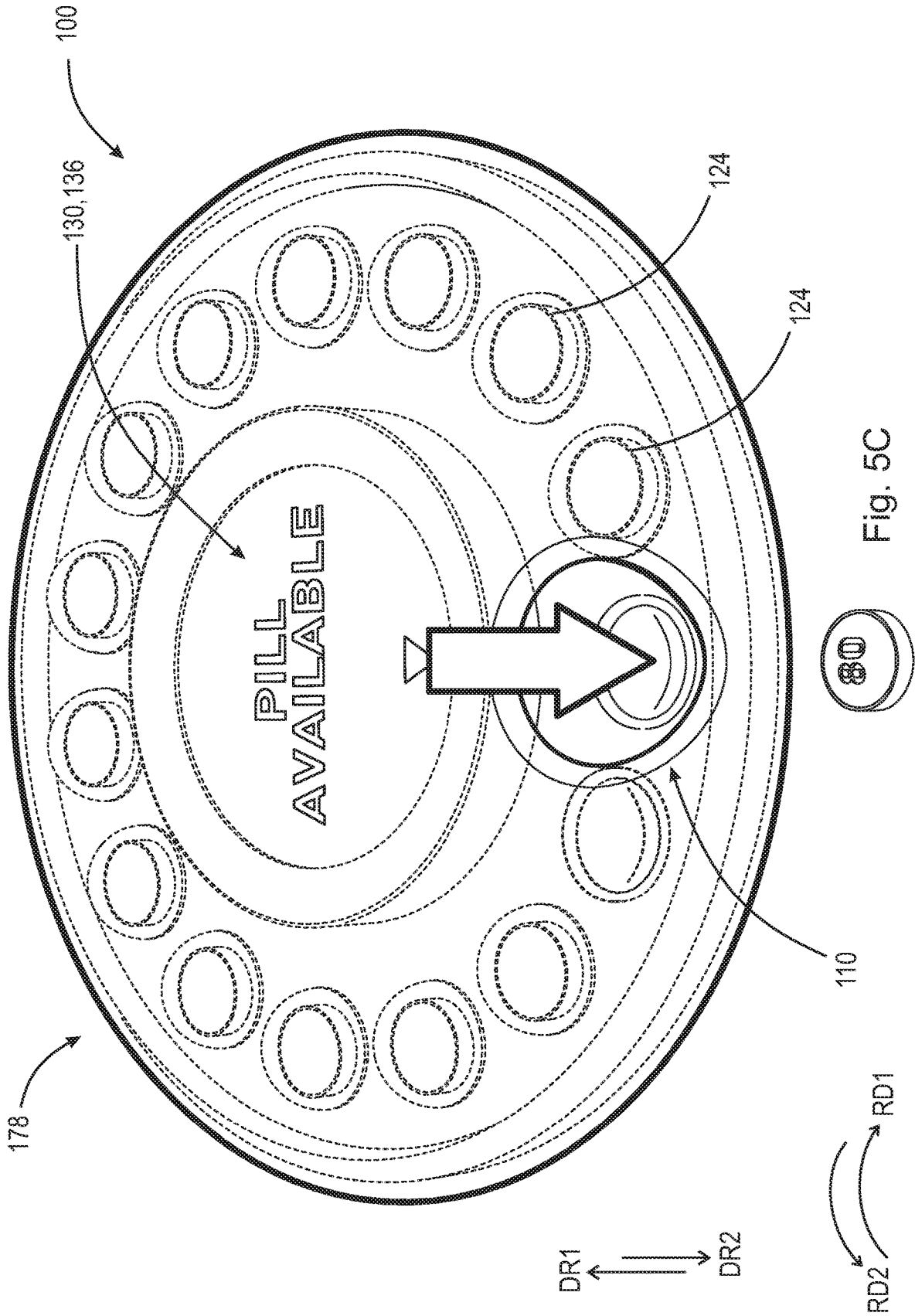

Fig. 5B



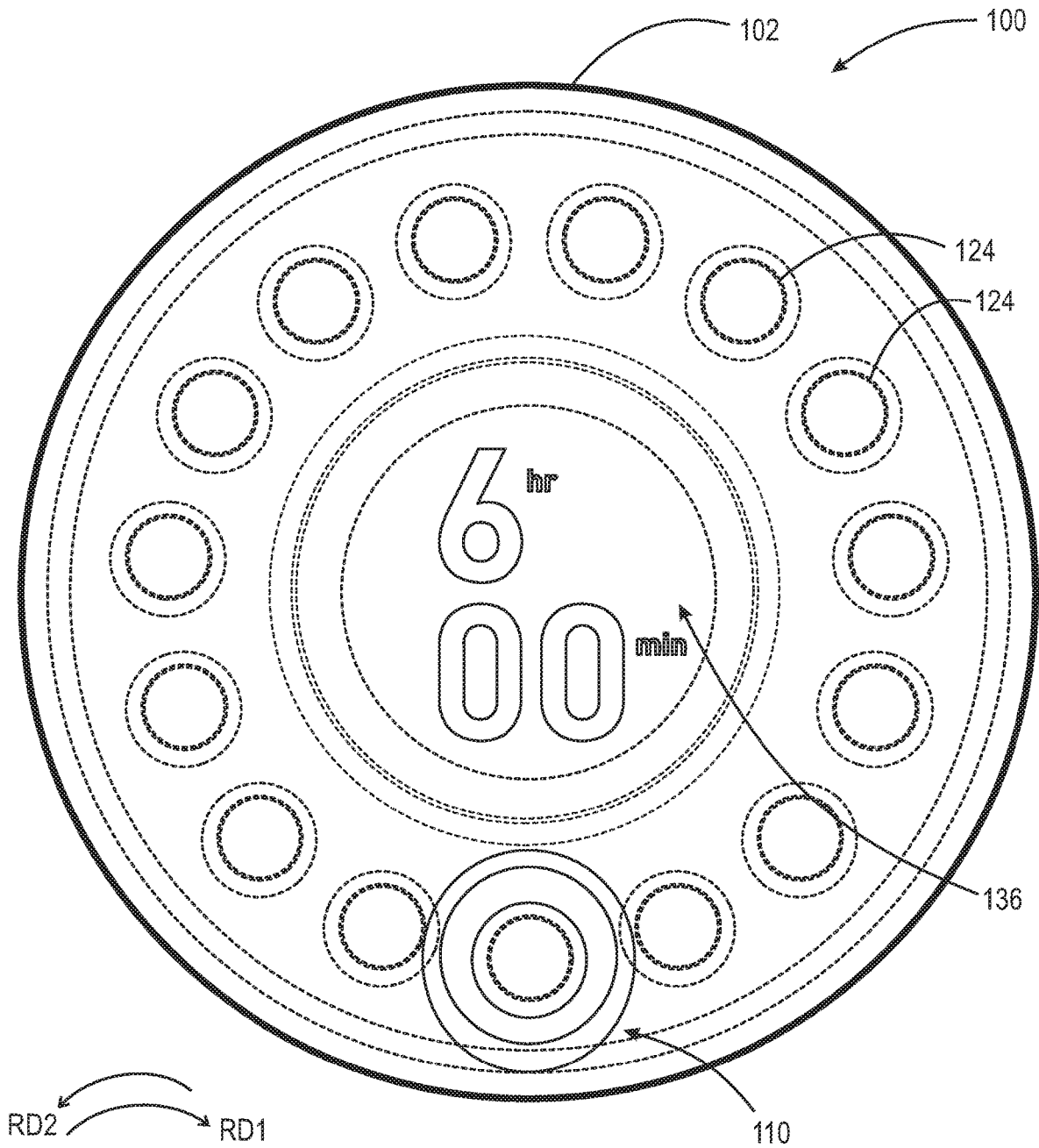

Fig. 6A

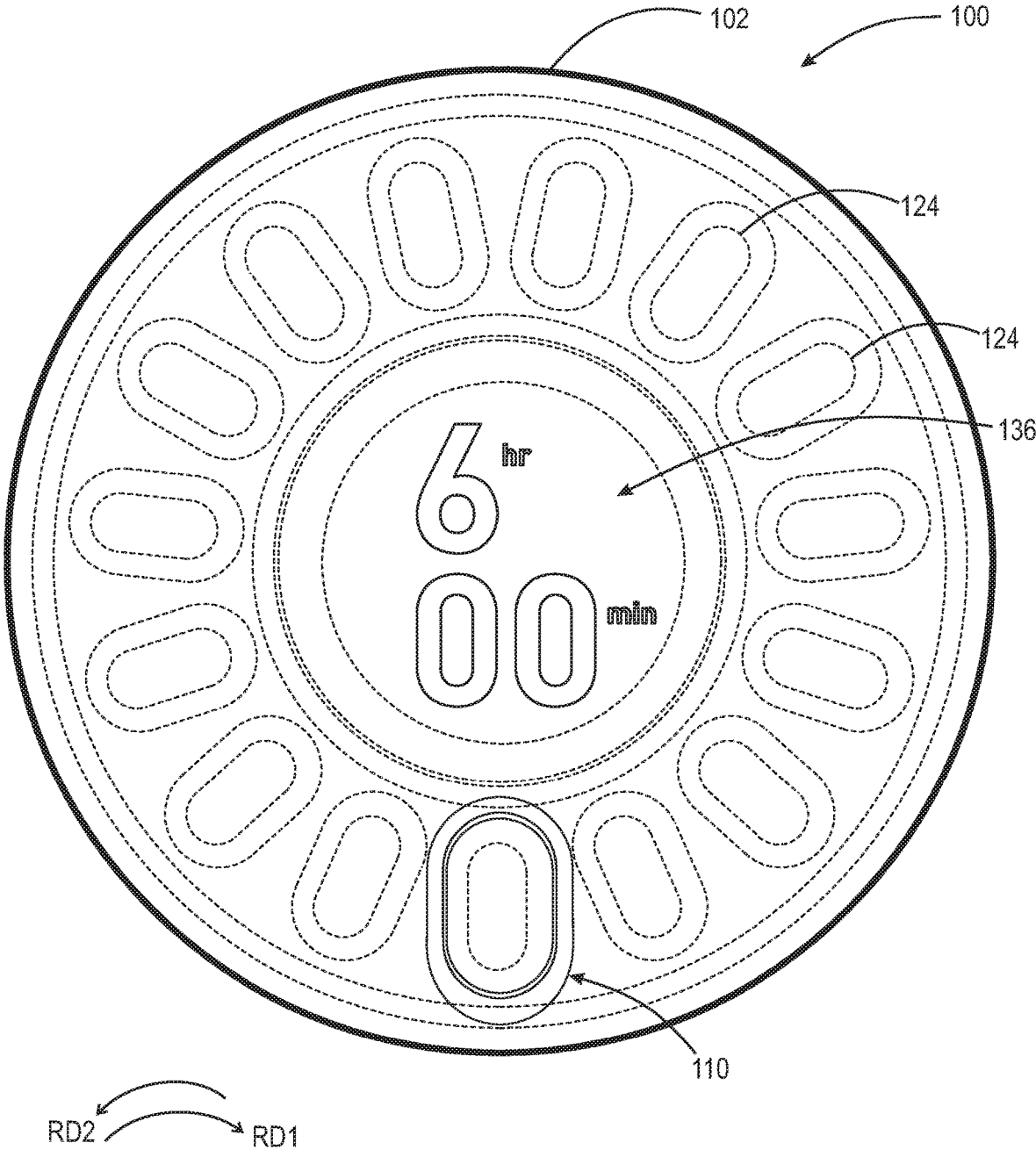

Fig. 6B

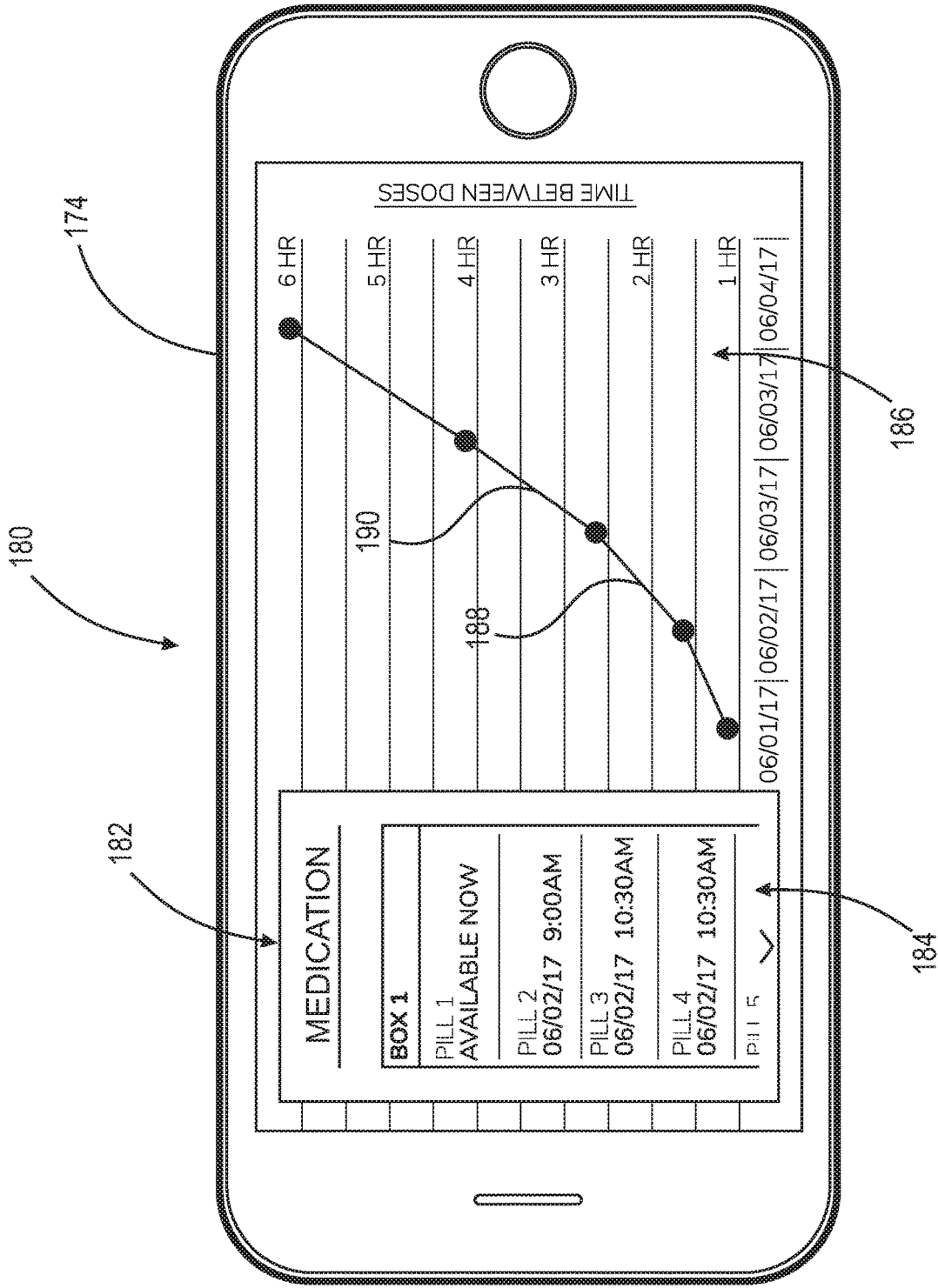

Fig. 7

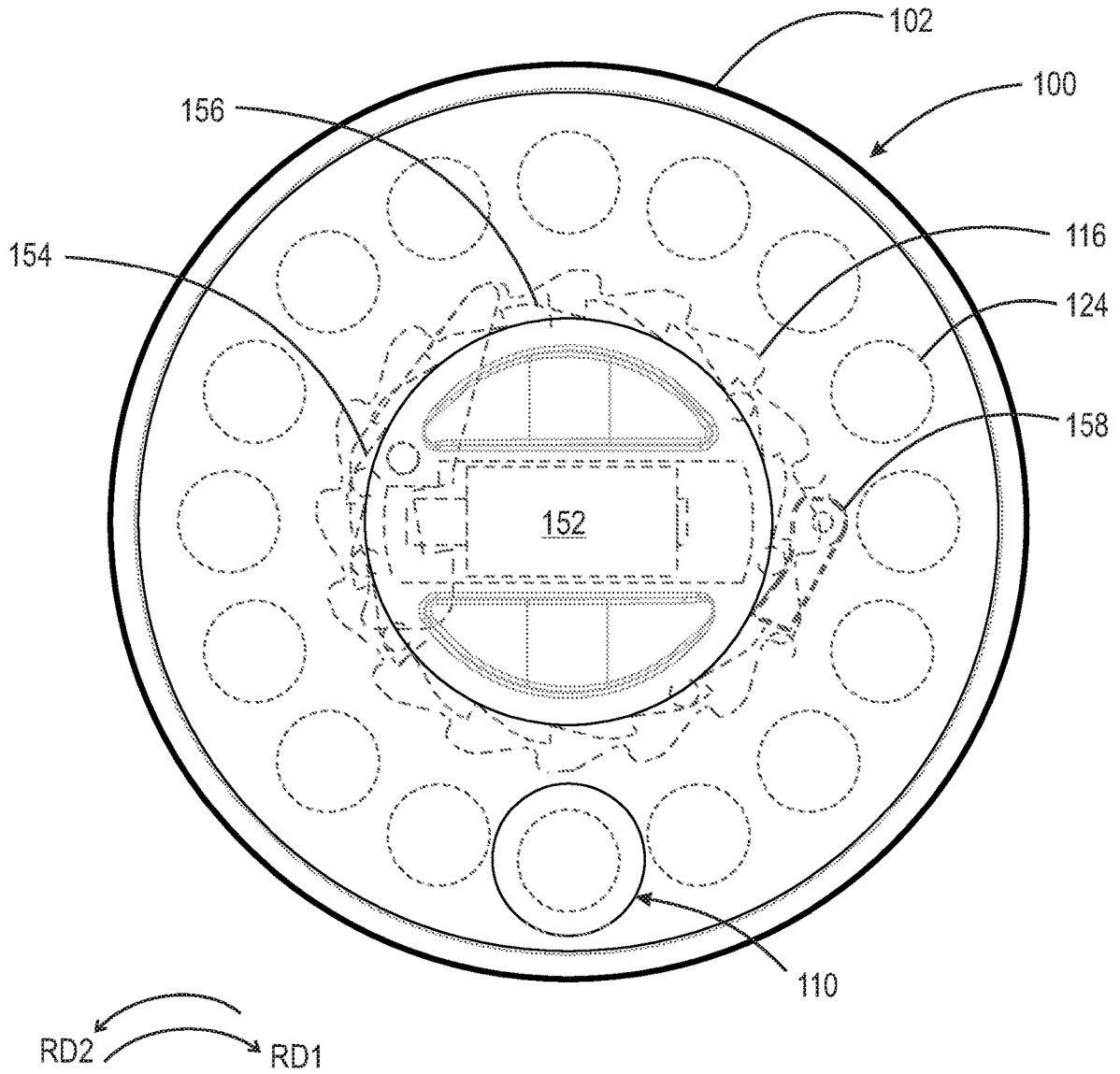

Fig. 8

TABLET AND CAPSULE DISPENSING ASSEMBLY

CROSS-REFERENCE TO RELATED APPLICATIONS

This application is filed under 35 U.S.C. §§ 111(a) and 365(c) as a continuation of International Patent Application No. PCT/US17/69049, filed Dec. 29, 2017, which application claims the benefit under 35 U.S.C. § 119(e) of U.S. Provisional Patent Application No. 62/440,569, filed on Dec. 30, 2016, which applications is herein incorporated by reference in its entirety.

FIELD

The disclosure relates to tablet and capsule dispensers, more particularly to tablet and capsule dispensers that dispense tablets and capsules in compliance with a predefined regimen specific to a time interval or schedule, and, even more specifically, to a tablet and capsule dispensers that prevent access to tablets and capsules except as specified by a pre-defined regimen.

BACKGROUND

Opioids are a type of medicine often used to help relieve pain. Opioids work by attaching themselves to specific proteins called opioid receptors, which are found in nerve cells in the brain, spinal cord, gastrointestinal tract, and other organs within the human body. When opiates attached to these receptors, they change how the brain perceives pain by creating feelings of pleasure and euphoria. The human brain is wired to record feelings of pleasure and euphoria, and cues the individual to take more and more of the drug. As a result, a user can become dependent on, and addicted to, opioids very quickly. Current estimates show that as many as 36 million users worldwide suffer from opioid addiction.

Opioid addiction quickly leads to adverse health effects such as dizziness, nausea, aches and pains, tremors, chills, vomiting, and constipation. In addition to these negative health effects, the user builds a tolerance to the positive effects of the opioid which can lead to overdose and death. In 2015, the Centers for Disease Control reported that drug overdoses accounted for 52,504 deaths in the United States, 63.1% of which involved and opioid.

As a result of the increased levels of addiction, prescription medications are typically controlled in a closed system of distribution which seeks to control the importation, manufacture, distribution, and dispensing of controlled substances. This closed system is designed to provide a discrete chain of custody for controlled substances, and ensure that those substances are used in accordance with a prescribed manner which is specific to a given quantity of the substance taken at defined intervals of time. This closed system effectively opens when a controlled substance is released into the hands of the patient or end-user. The end-user, while bound by the laws of use specified by the closed system, is largely free to operate on the honor system and trusted to follow the regimen specified by the prescription instructions.

Several unintended consequences arise from this honor system which include, but are not limited to; missed doses, over-doses, unused quantities of controlled substances, and access to controlled substances by non-authorized users. Further, well-meaning end-users often dispose of unused quantities of controlled substances into the wastewater sup-

ply where they contaminate water resources with unknown and poorly-studied consequences.

In the case of addictive substances such as opioids, an attractive nuisance is created whereby unauthorized users happen upon and ingest unused controlled substances and experience the euphoria associated with opioids and other strong pain medications. For many, this first experience leads to a downward spiral of abuse which tragically, and all too often, results in addiction, and a move to cheaper, more readily accessible street drugs like heroin. Deaths related to heroin and opioid abuse continue to spiral out of control, due in part, to the lack of control resulting from the current honor system of managing the distribution of controlled substances to end-users.

U.S. Pat. No. 7,978,5464 (De La Huerga) discloses a device which relies upon an electronic processor and communication with the end-user to remind of the proper dose, track usage, warn of drug interactions, but does not physically limit access to controlled substances. A further disadvantage of the device in De La Huerga is that the device relies upon separate consoles which would complicate adherence to regimens for end-users who are traveling or simply going about their daily lives, going to the market, or even visiting their physician.

U.S. Pat. No. 9,218,458 (Baarman) discloses another device that tracks usage, reminds and warns end users, using an additional electronic device in proximity with the invention before dispensing controlled substances. While this device moves to physically limit access, it requires an outboard device for user validation. Further, the invention automatically dispenses controlled substances according to a pre-defined regimen, but this may conflict with regimen instructions such as, "take as needed", or, "take one or two tablets, as needed."

United States Patent Application Publication No. 2014/0214200 (Chrusciel) controls dispensing "several non-individually packaged pills at a plurality of times". The nature of providing for a "plurality of removable magazines" results in a device that is much larger than is conveniently portable and requires an end-user to move all of their controlled substances about as a single group. The use of rechargeable batteries, charged from a wall outlet further restricts portability.

U.S. Pat. No. 8,622,241 (Geboers) describes a device where tablets or capsules are dispensed at preset intervals and quantities from columns of loose tablets, pills or capsules. The device is mechanical, or electromechanical, but requires an outboard unit containing a processor and communication device to track end-user behavior and to respond to flexible requirements embodied in many medication regimens.

U.S. Pat. No. 9,283,150 (Bujalski) describes a device that relies upon a mechanical timer to release controlled substances in accordance with a pre-defined regimen. End-users are alerted when the time interval is reached, but there is limited flexibility in managing instructions such as, "Take one or two tablets as needed". This invention lacks the ability to record and communicate a history of usage, and the ability to display remaining dosages, or time to next dosage.

Thus, there is a long-felt need for a tablet and capsule dispenser that prevents access to tablets and capsules except as specified by a pre-defined regimen and has the ability to record and communicate a history of usage, display remaining dosages, display time to next dosage, and prevent early access to the next dosage.

SUMMARY

According to aspects illustrated herein, there is provided a tablet and capsule dispensing assembly including a case,

3

the case having an inner circumferential surface, the inner circumferential surface having a first plurality of teeth, a tablet disc having a plurality of tablets disposed about a circumference of the tablet disc, the tablet disc arranged to rotate about a central axis and within the case, and a lock arranged to engage with the first plurality of teeth to prevent rotation of the tablet disc in a first rotational direction at a first predetermined time interval.

According to aspects illustrated herein, there is provided a tablet and capsule dispensing assembly, including a case having a superior component and an inferior component operatively arranged to form a first cavity therebetween, a tablet disc arranged within the first cavity, the tablet disc having a plurality of tablets disposed about a circumference of the tablet disc, and arranged to rotate about a central axis and within the case, and a lock arranged to prevent rotation of the tablet disc in a first rotational direction at a first predetermined time interval. The lock further includes a first component and a second component. The first component including a display and a first circuit electrically connected to the display. The second component including a solenoid actuator, a pivotable catch, a second plurality of teeth disposed on an outer circumferential surface of the second component, and a ratchet operatively arranged to engage with the second plurality of teeth and the case.

These and other objects, features, and advantages of the present disclosure will become readily apparent upon a review of the following detailed description of the invention in view of the drawings and appended claims.

BRIEF DESCRIPTION OF THE SEVERAL VIEWS OF THE DRAWINGS

Various embodiments are disclosed, by way of example only, with reference to the accompanying schematic drawings in which corresponding reference symbols indicate corresponding parts, in which:

FIG. 1A is a front perspective view of the top of the dispensing assembly as disclosed herein;

FIG. 1B is a front perspective view of the bottom of the dispensing assembly as disclosed herein;

FIG. 2A is a front perspective exploded view of the dispensing assembly of FIG. 1A;

FIG. 2B is a front perspective exploded view of the dispensing assembly of FIG. 1B;

FIG. 3 is a high-level schematic view of a circuit associated with the dispensing assembly as disclosed herein;

FIG. 4A is a front perspective view of the top of the dispensing assembly as disclosed herein;

FIG. 4B is a front perspective view of the bottom of the dispensing assembly as disclosed herein;

FIG. 5A is a front perspective view of the top of the dispensing assembly as disclosed herein;

FIG. 5B is a front perspective view of the top of the dispensing assembly as disclosed herein;

FIG. 5C is a front perspective view of the top of the dispensing assembly as disclosed herein;

FIG. 6A is a top plan view of an example embodiment of a dispensing assembly as disclosed herein;

FIG. 6B is a top plan view of an example embodiment of a dispensing assembly as disclosed herein;

FIG. 7 is a schematic view of an example embodiment of the software interface arranged for communication with the dispensing assembly as disclosed herein; and,

4

FIG. 8 is top plan view of an example embodiment of the dispensing assembly as disclosed herein.

DETAILED DESCRIPTION OF EMBODIMENTS

At the outset, it should be appreciated that like drawing numbers on different drawing views identify identical, or functionally similar, structural elements. It is to be understood that the claims are not limited to the disclosed aspects.

Furthermore, it is understood that this invention is not limited to the particular methodology, materials and modifications described and as such may, of course, vary. It is also understood that the terminology used herein is for the purpose of describing particular aspects only, and is not intended to limit the scope of the claims.

Unless defined otherwise, all technical and scientific terms used herein have the same meaning as commonly understood to one of ordinary skill in the art to which this invention pertains. It should be understood that any methods, devices or materials similar or equivalent to those described herein can be used in the practice or testing of the example embodiments. The assembly of the present invention could be driven by hydraulics, electronics, and/or pneumatics. It should be appreciated that the term "substantially" is synonymous with terms such as "nearly," "very nearly," "about," "approximately," "around," "bordering on," "close to," "essentially," "in the neighborhood of," "in the vicinity of," etc., and such terms may be used interchangeably as appearing in the specification and claims. It should be appreciated that the term "proximate" is synonymous with terms such as "nearby," "close," "adjacent," "neighboring," "immediate," "adjoining," etc., and such terms may be used interchangeably as appearing in the specification and claims. The term "approximately" is intended to mean values within ten percent of the specified value.

Moreover, as used herein, "and/or" is intended to mean a grammatical conjunction used to indicate that one or more of the elements or conditions recited may be included or occur. For example, a device comprising a first element, a second element and/or a third element, is intended to be construed as any one of the following structural arrangements: a device comprising a first element; a device comprising a second element; a device comprising a third element; a device comprising a first element and a second element; a device comprising a first element and a third element; a device comprising a first element, a second element and a third element; or, a device comprising a second element and a third element.

The term "Superior Component" as used in the present disclosure is intended to mean the component of the case located in the highest position relative to the inferior component component in first direction DR1.

The term "Inferior Component" as used in the present disclosure is intended to mean the component of the case located in the lowest position relative to the superior component in first direction DR1.

Adverting now to the figures, FIGS. 1A-2B illustrate various perspective views of dispensing assembly 100 in an assembled state and an exploded state. Dispensing assembly 100 includes case 102 which is substantially toroidal in shape. Case 102 includes superior component 104 and inferior component 106. Superior component 104 and inferior component 106 are arranged to engage via a press-fit, friction-fit, or interference-fit, leaving a substantially toroidal first cavity 108 therebetween. It is intended that superior component 104 and inferior component 106 are arranged

such that once they are fitted together, no user can open the case, e.g., only a manufacturer or healthcare professional may separate the components. In an example embodiment, superior component **104** and inferior component **106** are made of high impact modified Poly(methyl methacrylate) (PMMA); however, it should be appreciated that any other durable material can be used, e.g., high-density polyethylene, low-density polyethylene, metal, high-impact polystyrene, Polycarbonate (PC), Polyether Imide (PEI), or any other material which can resist breaking or cracking while in use, and prevent tampering and/or render evident any tampering caused by the user. Superior component **104** further includes aperture **110**, and inferior component **106** further includes aperture **112**. Apertures **110** and **112** are arranged such that when case **102** is assembled, aperture **110** of superior component **104** is aligned with, and directly above, aperture **112** of inferior component **106**. Superior component also includes first rim **114** (shown in FIG. 2B) which contains first plurality of teeth **116** disposed about a circumferential surface of first rim **114** and operatively arranged to engage with pivotable catch **152** discussed infra. Inferior component **106** further comprises opening **118** operatively arranged to receive second component **134** of lock **130** discussed infra; and, second rim **120** (shown in FIG. 2A) arranged to engage with lock **130** discussed infra.

Dispensing assembly **100** further comprises tablet disc **122**. Tablet disc **122** and lock **130** (discussed infra) are positioned within first cavity **108** of case **102** when dispensing assembly **100** is completely assembled. Tablet disc **122** further comprises plurality of tablets **124** disposed about the circumference of tablet disc **122**. The tablets of plurality of tablets **124** are set apart from each other a fixed circumferential distance such that they are evenly spaced. In an example embodiment, tablet disc **122** is a prefabricated blister pack with a plurality of individual cells which isolate a single dose of a particular medication, i.e., each tablet is intended to be a single dose of a particular medication. The distance between each tablet or cell and the size of apertures **110** and **112** are proportional such that access to tablets is limited to one tablet at a time through apertures **110** and **112**. Tablet disc **122** further comprises first through-bore **126** arranged to engage with first projection **140** (discussed infra) and at least one second through-bore **128** arranged to engage with at least one second projection **146** (not shown and discussed infra).

Dispensing assembly **100** further comprises lock **130**. Lock **130** comprises first component **132** and second component **134**. First component **132** comprises display **136**, and first circuit **138** (shown in FIG. 3). In an example embodiment, display **136** is an E-ink display; however, it should be appreciated that other displays are possible, e.g., a touch-screen display, an Light-Emitting Diode (LED) display, an Electroluminescent (ELD) display, a Plasma Display Panel (PDP) display, an Organic Light-Emitting Diode (OLED) display, a Liquid Crystal (LCD) display, or other equivalent displays. Display **136** is arranged to display the current state of dispensing assembly **100** and show the time interval remaining until tablet disc **122** can be rotated to the next position (description of use of the assembly described infra). Second component **134** comprises, first projection **140** having first surface **142**, second cavity **144**, at least one second projection **146** (not shown), second surface **148** having a plurality of grips **150**, solenoid actuator **152**, pivotable catch **154**, second plurality of teeth **156**, and ratchet **158**.

First projection **140** is a substantially cylindrical protrusion arranged to be concentric with second component **134** and further comprises second plurality of teeth **156**. Second

plurality of teeth **156** are operatively arranged on the outer circumference of first projection **140** and arranged to engage with ratchet **158**. First projection **140** further includes first surface **142**. First surface **142** comprises at least one second projection **146** (not shown) and second cavity **144**. At least one second projection **146** is a peg or other projection operatively arranged to protrude in first direction DR1 with respect to first surface **142** and engage with through-bores **128** of tablet disc **122**. When completely assembled, first projection **140** and at least one second projection **146** slide within, and engage with, first through-bore **126** and at least one second through-bore **128** of tablet disc **122**, respectively. Second cavity **144** is arranged to receive solenoid actuator **152** when dispensing assembly **100** is fully assembled. Second surface **148**, which is arranged opposite first surface **142** on second component **134**, includes plurality of grips **150**. Plurality of grips **150** are illustrated as two quadraspherical (one quarter of a sphere) cavities separated by a portion of second component **134**; however, it should be appreciated that any physical arrangement that allows for a user to provide sufficient torque on lock **130** to rotate second component **134** relative to first component **132** can be used. Plurality of grips **150** are arranged such that a user can grip and provide a rotational force in first rotational direction RIM or second rotational direction RD2 when a new tablet/pill is needed.

It should be appreciated that first plurality of teeth **116** and second plurality of teeth **156** can be angled such that they prevent rotational motion of tablet disc **122** in either first rotational direction RIM or second rotational direction RD2. For example, FIGS. 1A, 1B, and 4A-5C illustrate arrangements where ratchet **158** prevents rotational motion in rotational direction RD2 and pivotable catch **154** prevents and/or allows for rotational motion of tablet disc **122** in first rotational direction RD1. However, it should be appreciated that, as shown in FIGS. 2A, 2B and 8, first plurality of teeth **116** and second plurality of teeth **156** can be angled such that ratchet **158** prevents rotational motion of tablet disc **122** in first rotational direction RD1 and pivotable catch **154** prevents and/or allows for rotational motion of tablet disc **122** in second rotational direction RD2.

Solenoid actuator **152** is operatively arranged to sit within second cavity **144** and engage with pivotable catch **154** causing pivotable catch **154** to pivot and engage and/or disengage with first plurality of teeth **116** of superior component **104**. As illustrated in FIGS. 1A, 1B, and 4A-5C, when solenoid actuator **152** is disengaged, tablet disc **122** is prevented from rotating in a first rotational direction RD1 and second rotational direction RD2. When solenoid actuator **152** is engaged, i.e., extended, tablet disc **122** is free to rotate in first rotational direction RD1. It should be appreciated that any actuator known in the art can be used to engage with first plurality of teeth **116**. Pivotable catch **154** has a peg which rotatably engages with a partial through-bore disposed within first surface **142** of second component **134** such that it can pivot when engaged with solenoid actuator **152**. First plurality of teeth **116** and pivotable catch **154** are arranged such that they are not affected by vibrations or gyrations which could be experienced in the average use of the assembly.

It should be appreciated that second component **134** is operatively arranged to sit within, and rotate independently from, first component **132**. First component **132** is intended to remain non-rotatably secured to superior component **104** such that, when tablet disc **124** and second component **134** rotate in second rotational direction RD2, first component **132**, which contains display **136**, remains rotationally locked

in case **102**. This ensures that the display is always visible from the side of dispensing assembly **100** that comprises apertures **110** and **112**. Additionally, as solenoid actuator **152** must be permitted to rotate with second component **134** while simultaneously maintaining electronic communication with first circuit **138**, solenoid actuator **152** can be electrically connected to first circuit **138** with any wired or wireless circuit capable of transferring electricity to a rotating body, e.g., electrical slip rings, pancake slip rings, wireless slip rings, wireless power transfer circuits, inductive power transfer circuits, etc.

FIG. 3 illustrates a high-level schematic view of first circuit **138**. First circuit **138** comprises microcontroller **160**, timer **162**, antenna **164**, power supply **166**, and flex circuit **168**, and sensor **169**. Microcontroller **160** further includes processor **170** and memory **172**, which are operatively arranged to store and execute a set of non-transitory computer readable instructions. Memory **172** can store a first data set comprised of at least one date, at least one time, a rotational position of the tablet disc, and an integer. The date, time, and integer can reflect the history of a user's interaction with dispensing assembly **100** and keep track of which pill/tablet was accessed at what time. In an example embodiment, microcontroller **160** is a Cypress Semiconductor part no.: CY8C4247LQI-BL483 available from Mouser Electronics; however, it should be appreciated that any other suitable microcontroller could be used to store the set of non-transitory computer readable instructions and first data set.

Timer **162** is a simple circuit operatively arranged to provide a base time signal to a microcontroller. This circuit comprises, for example, a crystal quartz oscillator. In an example embodiment timer **162** is a crystal oscillator part no.: ECS-240-8-36CKM available from ECS Inc.; however, it should be appreciated that any crystal oscillator that can communicate with microcontroller **160** and keep time can be utilized. Antenna **164** is operatively arranged to communicate with microcontroller **160** and can be utilized to send/receive a wireless signal/communication. It should be appreciated that "wireless communication(s)" as used herein is intended to mean Radio Frequency Identification (RFID) communication, Bluetooth® protocols, Near field Communication (NFC), Near Field Magnetic Inductance Communication (NFMIC), Wi-Fi, LTE, Airdrop® communication, or any other wireless protocol sufficient to communicate with microcontroller **160**. Additionally, display **136** is capable of rendering a visible image, e.g., a bar code or QR code, which can be scanned by an external device as a means for transmitting information from dispensing assembly **100**. In an example embodiment antenna **164** is part no.: 2450AT42E0100 available from Johanson Technology Inc.; however it should be appreciated that any antenna capable of communication via the above-identified protocols can be used. Power supply **166** is intended to be a battery or any combination of multiple batteries that can produce sufficient voltage to power the components in first circuit **138**, solenoid actuator **152**, and display **136**. Flex circuit **168** is a flexible ribbon-type circuit that is operatively arranged to bend and flex such that electrical current may still flow from microcontroller **160** to display **136**. Furthermore, sensor **169** is arranged to sense and store the rotational position of tablet disc **122**. It should be appreciated that a sensor **169** could be embodied as an optical sensor, limit-switch, or other device capable of sensing a position of tablet disc **122** can be included in first circuit **138**.

The following description is intended to illustrate one potential operation of dispensing assembly **100** and should

be read in view of FIGS. 4A-5C. Initially, a user will receive dispensing assembly **100** from the manufacturer, pharmacist, or other healthcare professional. The dispensing assembly will come pre-assembled and closed as illustrated in FIGS. 4A and 4B. In initial position **176**, one tablet of plurality of tablets **124** is aligned with first aperture **110** and second aperture **112** and can be depressed and removed from tablet disc **122** by the user. Additionally, in initial position **176**, display **136** indicates that the first tablet, aligned with apertures **110** and **112**, is available for dispensing. Once the first tablet of plurality of tablets **124** is dispensed, the user can ingest the tablet. In initial position **176**, ratchet **158** (shown in FIGS. 2A and 2B), which is pivotably mounted on second rim **120** (shown in FIG. 2A) of inferior component **106**, is spring loaded such that it is engaged with one of the second plurality of teeth **156** (shown in FIG. 2A) of second component **134** preventing rotation of lock **130** in second rotational direction RD2. Second plurality of teeth **156** and ratchet **158** are arranged such that they are not affected by vibrations or gyrations which could be experience in the average use of the assembly. Additionally, in initial position **176** solenoid actuator **152** (shown in FIGS. 2A and 2B) is in an activated state, i.e., positioned such that the plunger is in an extended position. In this extended position, solenoid actuator **152** engages with pivotable catch **154** (shown in FIGS. 2A and 2B). Pivotable catch **154** pivots about a peg or other protrusion which is disposed within a third cavity on first surface **142** (shown in FIG. 2A) of first projection **140** (shown in FIG. 2A) of second component **134**. In this state, pivotable catch **154** is not engaged with first plurality of teeth **116** (shown in FIG. 2B) of superior component **104**, and second component **134** and tablet disc **122** are free to rotate in second rotational direction RD2.

To advance the dispensing assembly to second position **178**, illustrated in FIGS. 5A-5C, the user engages with plurality of grips **150** disposed on second surface **148** of the second component **134** of lock **130**. The user applies a rotational force in first rotational direction RIM. When sensor **169** indicates that tablet disc **122** has been rotated to second position **178**. Activation of sensor **169** simultaneously causes solenoid actuator **152** to retract and timer **162** to activate, beginning a counting down proportional to first time interval **188** discussed infra. When solenoid actuator **152** is in the retracted state, pivotable catch **154** will engage with one of first plurality of teeth **116** of superior component **104** and prevent further rotational motion in second rotational direction RD2. Although not illustrated this may be accomplished with some biasing device, e.g., a spring, which biases pivotable catch **154** towards first plurality of teeth **116**. Once in second position **178**, a second tablet will be positioned and aligned with apertures **110** and **112** allowing the second tablet to be dispensed from dispensing assembly **100**. At this point, the user must wait until the expiration of first time interval **188**, for solenoid actuator **152** to engage with pivotable catch **154** and allow for rotation of tablet disc **122** to the next position. This process is repeated until all of the tablets of plurality of tablets **124** are utilized. Once the tablet disc is empty, the user can either dispose of the device, or return it to their healthcare provider for further analysis of usage discussed infra.

It should also be appreciated that the first pill/tablet slot of tablet disc **122** can be left empty, i.e., without a tablet present. This arrangement would be utilized in situations where a patient has been given a first dose of medication via a healthcare provider. In this situation, the healthcare pro-

vider or user would then rotate tablet disc **122** into second position **178** and trigger the countdown proportional to first time interval **188**.

FIGS. 6A and 6B illustrate a top plan view of dispensing assembly **100**. These views illustrate some of the potential variations in size and shape of tablets which can be utilized in tablet disc **122**. The tablets of plurality of tablets **124** can be shaped as ovoid, cylindrical, triangular, or other suitable shape for ingestion. It should be appreciated that the variations shown are non-exhaustive of the potential sizes and shapes available. For example, any shape tablet can be used that can be pushed through apertures **110** and **112**.

FIG. 7 illustrates a schematic view of first computer **174** and software interface **180**. First computer **174** and software interface **180** are arranged for communication with dispensing assembly **100**. Software interface **180** is arranged to display first medication **182**, list **184** arranged to show an organized list of the various dates and times each pill/tablet will become available, and graph **186** arranged to show a graphical illustration of the various dates and times recorded in list **184**. In an example embodiment, first computer **174** is a smart phone; however, it should be appreciated that any other computer capable of sending and receiving wireless communications with antenna **164** can be used. First computer **174** is operatively arranged to receive/transmit wireless communications to and from antenna **164** discussed supra. First computer **174** may send an initial query to antenna **164**, which query can be electrically transferred to microcontroller **160**. Although not illustrated, it should also be appreciated that dispensing assembly **100** can communicate with first computer **174** via a wired connection, e.g., Ethernet cable, USB cable, or docking station. Microcontroller **160** can retrieve the data of the first data set, discuss supra, from memory **172** and transmit the first data set from antenna **164** to first computer **174** for display in software interface **180** of first computer **174**. It should be appreciated that software interface **180** can be arranged to display more than one medication, e.g., a second medication, third medication, fourth medication simultaneously.

It should also be appreciated that multiple time intervals can be set by the pharmacist, manufacturer, or other healthcare provider, e.g., first time interval **188** and second time interval **190**. First time interval **188** and second time interval **190** can be identical or they can be different e.g., the time between access to the first tablet and second tablet can be different than the time interval between the third tablet and fourth tablet. Additionally, the time intervals can vary e.g., the time between access to each tablet can range from days to seconds. It should further be appreciated that a final time period may be utilized in addition to first time interval **188** and second time interval **190**. The final time period can be utilized to set a value of time, that when expired the device remains rotationally locked until accessed by the pharmacist, manufacturer, or other healthcare provider. For example, a final time period could be utilized in the event the dispensing assembly is used to administer doses of medication for clinical trials. If a clinical trial, having a set period of 10 days is established, the device may allow access to each tablet at predetermined time intervals in addition to locking the device permanently at the end of the ten day period. This will allow the administrators of the trial to gather evidence of a patient failing to take the medications at the prescribed time intervals.

FIG. 8 is top plan view of dispensing assembly **100** in an assembled state. In this view, the interaction between ratchet **158** and second plurality of teeth **156**, as well as, the interaction between pivotable catch **154** and first plurality of

teeth **116** can be seen. This view also illustrates the interaction between solenoid actuator **152** and pivotable catch **154**, in that, the actuator plunger of solenoid actuator **152** sits within a notch arranged within pivotable catch **154**.

It will be appreciated that various aspects of the disclosure above and other features and functions, or alternatives thereof, may be desirably combined into many other different systems or applications. Various presently unforeseen or unanticipated alternatives, modifications, variations, or improvements therein may be subsequently made by those skilled in the art which are also intended to be encompassed by the following claims.

LIST OF REFERENCE NUMERALS

- DR1 Direction
- DR2 Direction
- RD1 Rotational direction
- RD2 Rotational direction
- 100** Dispensing assembly
- 102** Case
- 104** Superior component
- 106** Inferior component
- 108** First cavity
- 110** First aperture
- 112** Second aperture
- 114** First rim
- 116** First plurality of teeth
- 118** Opening
- 120** Second rim
- 122** Tablet disc
- 124** Plurality of tablets
- 126** First through-bore
- 128** Second through-bore
- 130** Lock
- 132** First component
- 134** Second component
- 136** Display
- 138** First circuit
- 140** First projection
- 142** First surface
- 144** Second cavity
- 146** Second projection
- 148** Second surface
- 150** Plurality of grips
- 152** Solenoid actuator
- 154** Pivotable catch
- 156** Second plurality of teeth
- 158** Ratchet
- 160** Microcontroller
- 162** Timer
- 164** Antenna
- 166** Power supply
- 168** Flex circuit
- 169** Sensor
- 170** Processor
- 172** Memory
- 174** First computer
- 176** Initial position
- 178** Second position
- 180** Software interface
- 182** First medication
- 184** List
- 186** Graph
- 188** First time interval
- 190** Second time interval

What is claimed is:

1. A tablet and capsule dispensing assembly, comprising:
 - a case having a superior component and an inferior component, the superior component and the inferior component operatively arranged to form a first cavity therebetween, the superior component comprising an inner circumferential surface including a first plurality of teeth;
 - a tablet disc arranged within the first cavity, the tablet disc having a plurality of tablets disposed about a circumference of the tablet disc, and arranged to rotate within the case; and,
 - a lock arranged to prevent rotation of the tablet disc in a first rotational direction during a first predetermined time interval, the lock comprising:
 - a first component, the first component comprising:
 - a display and a first circuit electrically connected to the display; and,
 - a second component, the second component comprising:
 - an actuator;
 - a pivotable catch arranged to engage with the first plurality of teeth to prevent rotational movement of the lock in the first rotational direction with respect to the case;
 - a second plurality of teeth disposed on an outer circumferential surface of the second component; and,
 - a ratchet operatively arranged to engage with the second plurality of teeth and the case.
2. The tablet and capsule dispensing assembly of claim 1, wherein the superior component further comprises a first aperture and the inferior component further comprises a

second aperture where the first aperture and the second aperture are arranged to allow a first tablet to be removed from the tablet disc.

3. The tablet and capsule dispensing assembly of claim 1, wherein the superior component and inferior component are made from Poly(methyl methacrylate), high-density polyethylene (HDPE), low-density polyethylene (LDPE), metal, high-impact polystyrene, Polycarbonate (PC), or Polyether Imide (PEI).
4. The tablet and capsule dispensing assembly of claim 1, wherein the display is an E-ink display, a touch-screen display, an Light-Emitting Diode (LED) display, an Electroluminescent (ELD) display, a Plasma Display Panel (PDP) display, an Organic Light-Emitting Diode (OLED) display, or a Liquid Crystal (LCD) display.
5. The tablet and capsule dispensing assembly of claim 1, wherein the first circuit comprises a microcontroller having a first memory storage unit, a timer, and a power supply, wherein the display, the microcontroller, the timer, and the actuator are all electrically connected.
6. The tablet and capsule dispensing assembly of claim 1, wherein the second component further comprises a first surface including a second cavity, the second cavity operatively arranged to receive the actuator.
7. The tablet and capsule dispensing assembly of claim 1, wherein the tablet disc is arranged to rotate a first rotational distance in a second rotational direction, opposite the first rotational direction, wherein the first rotational distance is less than or equal to a distance between a first tablet and a second tablet of the plurality of tablets on the tablet disc.
8. The tablet and capsule dispensing assembly of claim 1, wherein the actuator is a solenoid actuator.

* * * * *