



(12) **United States Patent**
Gardner et al.

(10) **Patent No.:** **US 10,428,536 B2**
(45) **Date of Patent:** **Oct. 1, 2019**

(54) **SCAFFOLD SYSTEM**
(71) Applicant: **International Chimney Corporation**,
Williamsville, NY (US)
(72) Inventors: **George R. Gardner**, East Amherst, NY
(US); **Edmund P. Gasiiecki**,
Cheektowaga, NY (US)
(73) Assignee: **International Chimney Corporation**,
Williamsville, NY (US)

(56) **References Cited**
U.S. PATENT DOCUMENTS
898,368 A * 9/1908 Humpheries E04G 5/04
182/87
2,673,711 A 10/1951 Lutton
2,718,378 A 9/1955 Lutton
(Continued)

(*) Notice: Subject to any disclaimer, the term of this
patent is extended or adjusted under 35
U.S.C. 154(b) by 334 days.

FOREIGN PATENT DOCUMENTS
CA 2313513 A1 * 1/2002 E04G 1/20
CA 2313513 A1 * 1/2002 E04G 1/20
(Continued)

Primary Examiner — Katherine W Mitchell
Assistant Examiner — Candace L Bradford
(74) *Attorney, Agent, or Firm* — Simpson & Simpson,
PLLC

(21) Appl. No.: **14/143,148**
(22) Filed: **Dec. 30, 2013**

(57) **ABSTRACT**

(65) **Prior Publication Data**
US 2015/0184402 A1 Jul. 2, 2015
(51) **Int. Cl.**
E04G 3/28 (2006.01)
E04G 3/20 (2006.01)
E04G 3/24 (2006.01)
E04G 5/06 (2006.01)
(52) **U.S. Cl.**
CPC **E04G 3/28** (2013.01); **E04G 3/20**
(2013.01); **E04G 3/246** (2013.01); **E04G 5/06**
(2013.01); **E04G 2003/286** (2013.01)

A scaffold system adapted for securing to a structure and for
vertical movement relative to the structure. The scaffold
system includes first and second wall mounts, each of the
wall mounts having a bar and at least one spring biasing the
bar in a first direction, a slide post having a slide hook, a
slide arm and a hanging pad secured to the slide arm, the
slide post arranged for vertical axial movement within at
least one of the first and second wall mounts, a main post
having at least one post hook, a first deck fixedly secured
to the main post, and a ball screw jack having a mounting plate
and a lifting screw, the mounting plate secured to the first
deck and the lifting screw secured to the hanging pad. The
main post is arranged to complementarily fit within slide
post, the slide hook is adapted for releasable engagement
with the first wall mount bar or the second wall mount bar
and the at least one post hook is adapted for releasable
engagement with the first wall mount bar or the second wall
mount bar.

(58) **Field of Classification Search**
CPC E04G 5/04; E04G 5/06; E04G 1/18; E04G
1/20; E04G 1/22; E04G 3/20; E04G 3/28;
E04G 3/00; E04G 2003/28; E04G
2003/286; E04G 11/22; E04G 11/24;
E04G 11/28

See application file for complete search history.

11 Claims, 9 Drawing Sheets

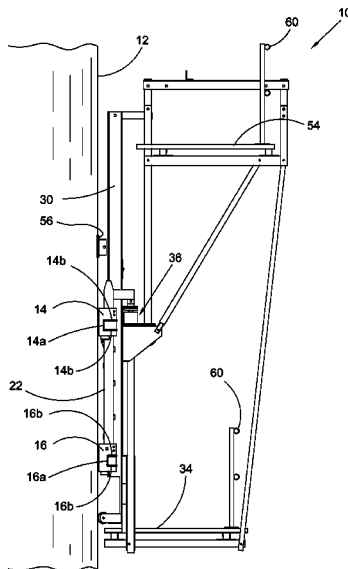

(56)

References Cited

U.S. PATENT DOCUMENTS

2,762,659 A * 9/1956 Harlan E04G 1/22
 182/141
 2,882,100 A * 4/1959 Bank E04G 5/00
 182/115
 2,893,786 A * 7/1959 Faye E04G 3/20
 182/229
 3,148,857 A * 9/1964 Hutchison E04G 5/06
 108/135
 3,371,551 A * 3/1968 Profet F16H 25/2223
 74/424.86
 4,040,774 A * 8/1977 Scheller E04G 11/28
 249/20
 4,078,633 A * 3/1978 Fahy E04G 1/20
 182/145
 4,157,129 A * 6/1979 Christopher E04G 1/20
 182/82
 4,275,797 A 6/1981 Johnson
 4,276,957 A * 7/1981 Kilgore E04G 3/22
 182/130
 4,476,958 A 10/1984 Stafford
 4,498,556 A * 2/1985 Garton B66F 11/04
 182/19
 4,690,606 A * 9/1987 Ross B64F 1/32
 187/214
 4,817,759 A * 4/1989 Galyardt E04G 3/18
 182/36
 4,962,828 A * 10/1990 Duncan E04G 21/3223
 182/82
 5,099,953 A 3/1992 Stegath
 5,152,369 A 10/1992 Nakaoka
 5,285,869 A 2/1994 Rock
 5,505,318 A * 4/1996 Goff A47B 46/00
 211/132.1
 5,579,866 A 12/1996 Rowell
 5,588,500 A 12/1996 Yonahara
 5,810,114 A 9/1998 White
 5,909,783 A 6/1999 Berish
 6,220,391 B1 4/2001 White
 6,431,316 B1 8/2002 Bothwell
 6,443,262 B1 9/2002 Karanough
 6,557,817 B2 * 5/2003 Waldschmitt E04G 11/28
 182/36

6,695,097 B1 2/2004 Wiklund
 6,883,642 B2 4/2005 Matty
 7,140,467 B2 * 11/2006 Cook B60R 3/005
 182/143
 7,188,707 B2 3/2007 Bothwell et al.
 8,302,735 B2 11/2012 Anasis et al.
 2006/0124392 A1 * 6/2006 Evinger E04G 3/28
 182/82
 2006/0163001 A1 * 7/2006 Pozell E04G 3/20
 182/82
 2007/0000724 A1 1/2007 Anasis et al.
 2007/0119116 A1 * 5/2007 Arozena Bergaretxe
 E04G 11/28
 52/633
 2007/0278041 A1 12/2007 Cosgrove et al.
 2008/0179477 A1 7/2008 Harney
 2009/0173574 A1 * 7/2009 Hobmeier E04G 11/28
 182/82
 2012/0247870 A1 * 10/2012 Iturbe Beristain
 E04G 21/3247
 182/82
 2012/0312940 A1 * 12/2012 Julliard E04G 3/22
 248/200.1
 2013/0081902 A1 * 4/2013 Liao E04G 3/28
 182/20

FOREIGN PATENT DOCUMENTS

DE 1116378 B * 11/1961 E04G 5/04
 DE 1116378 B * 11/1961 E04G 5/04
 DE 2921636 A1 * 12/1980 E04G 3/28
 DE 2921636 A1 * 12/1980 E04G 3/28
 DE 8702952 U1 * 9/1987 E04B 1/4121
 FR 340379 A * 7/1904 E04G 5/04
 FR 340379 A * 7/1904 E04G 5/04
 FR 2487410 A1 * 1/1982 E04G 11/28
 FR 2487410 A1 * 1/1982 E04G 11/28
 GB 2112440 A * 7/1983 E04G 3/20
 GB 2112440 A * 7/1983 E04G 3/20
 JP 8119589 5/1996
 JP 2000001984 1/2000
 WO 93/02263 2/1993
 WO WO-2013185277 A1 * 12/2013 E04G 11/28
 WO WO 2013185277 A1 * 12/2013 E04G 11/28

* cited by examiner

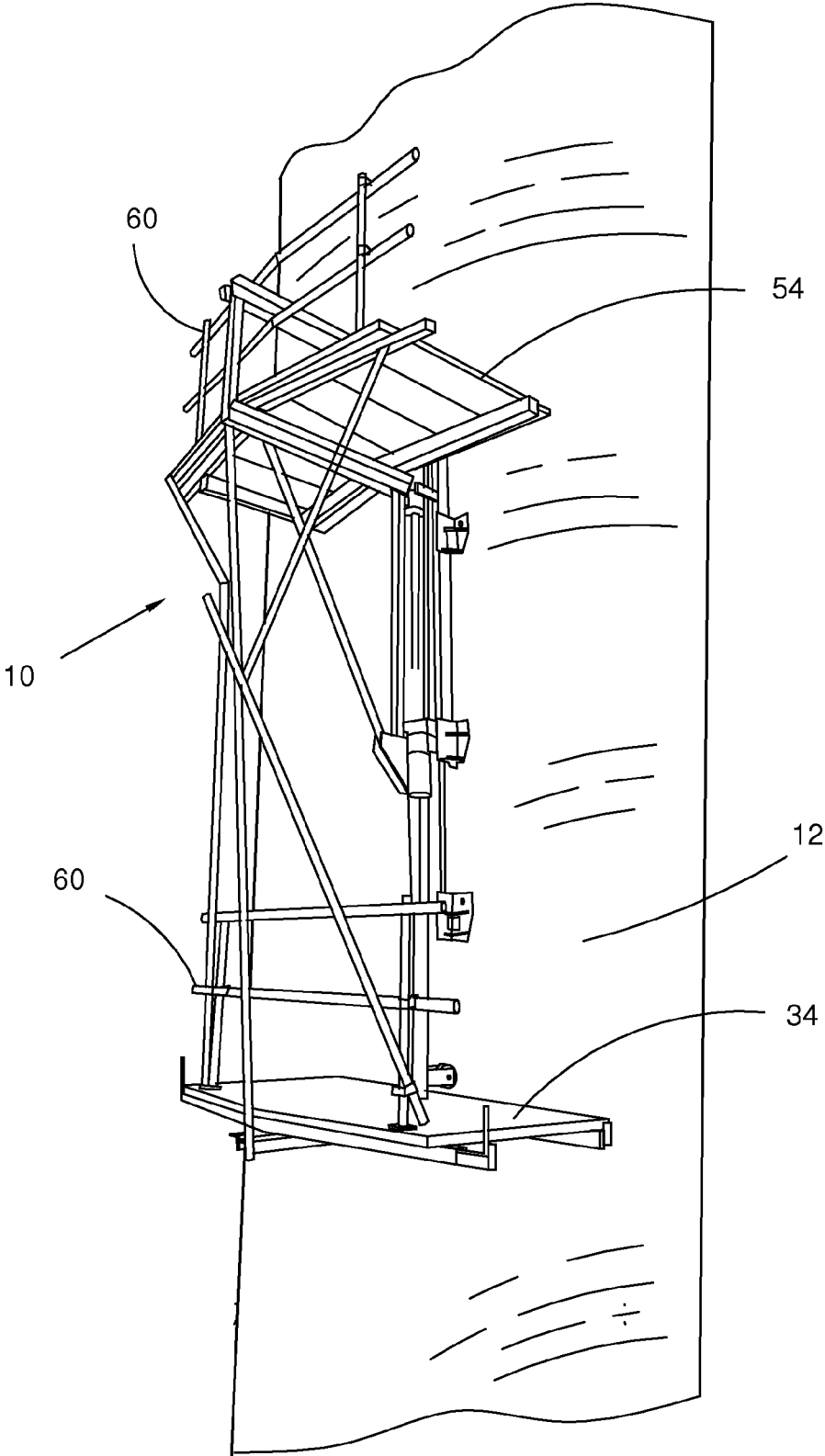

Fig. 1

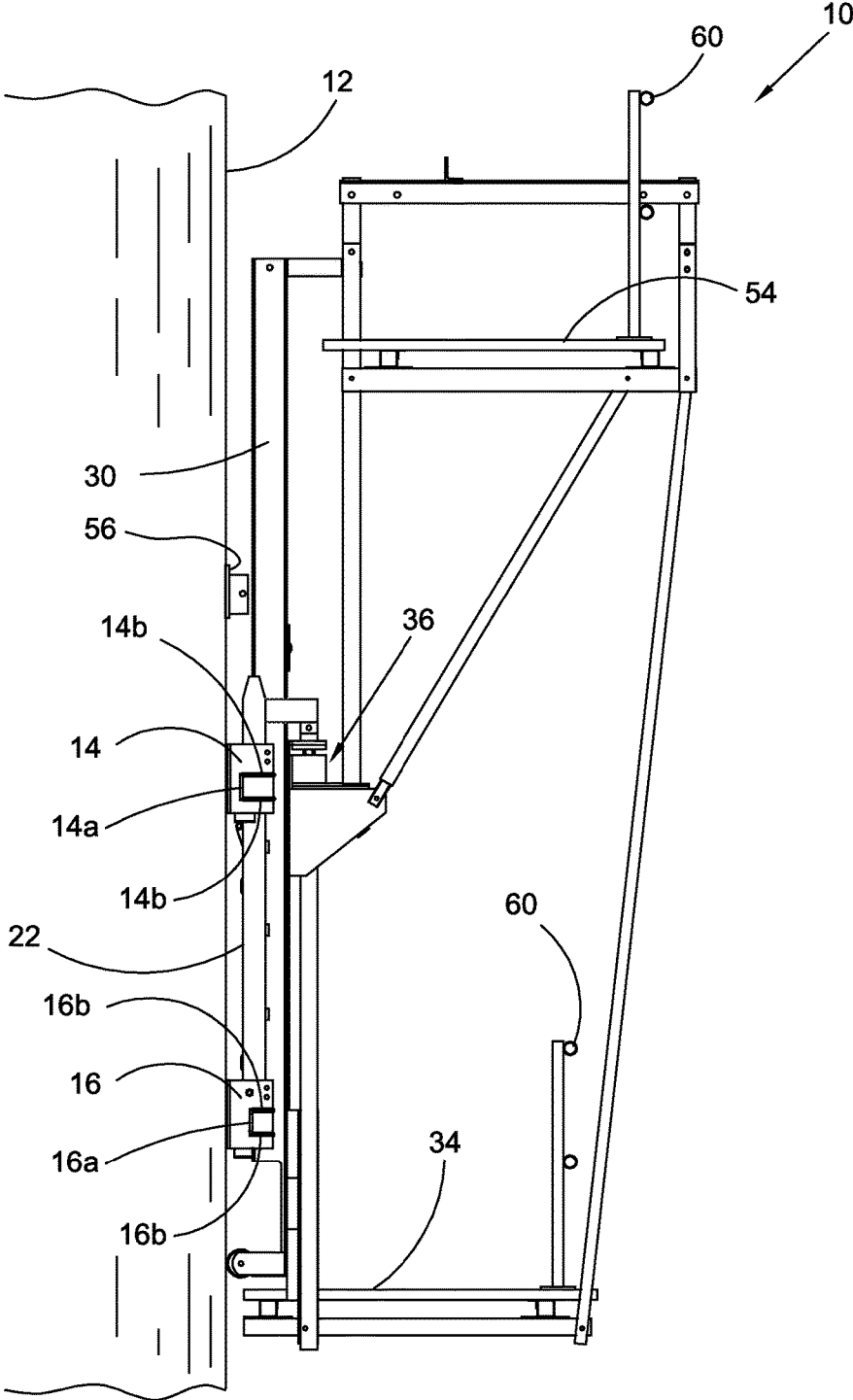

Fig. 2

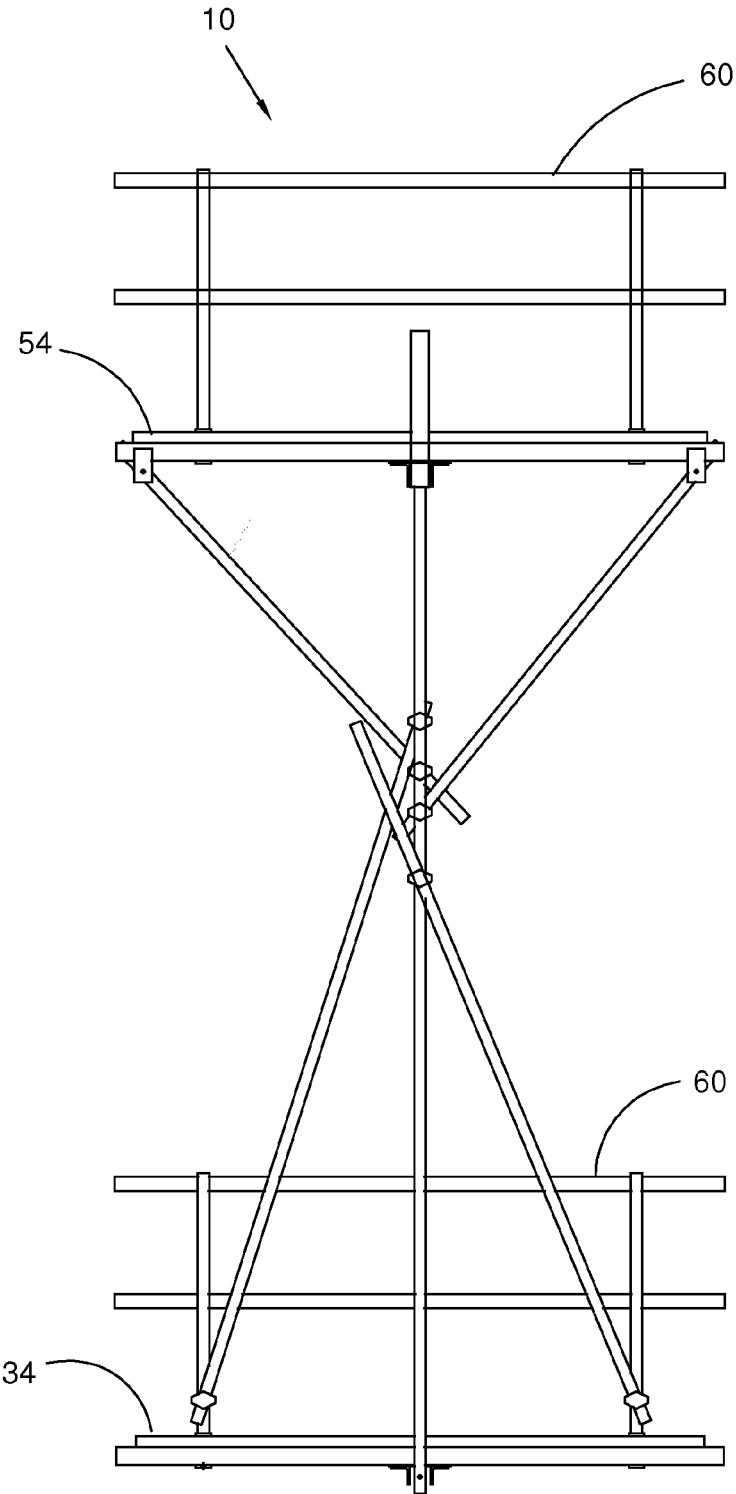

Fig. 3

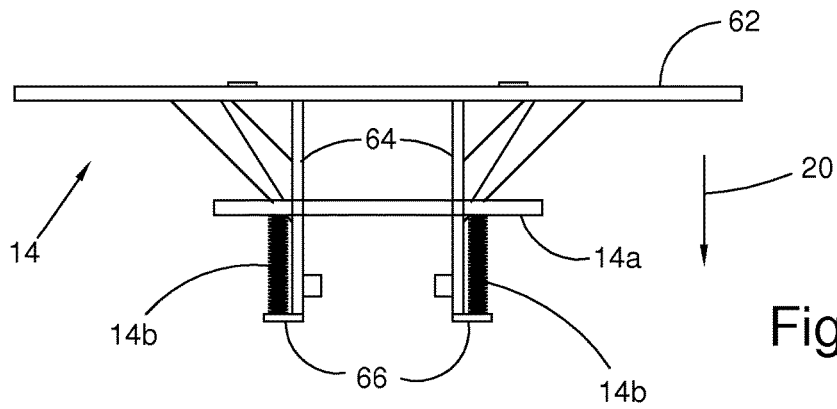

Fig. 4

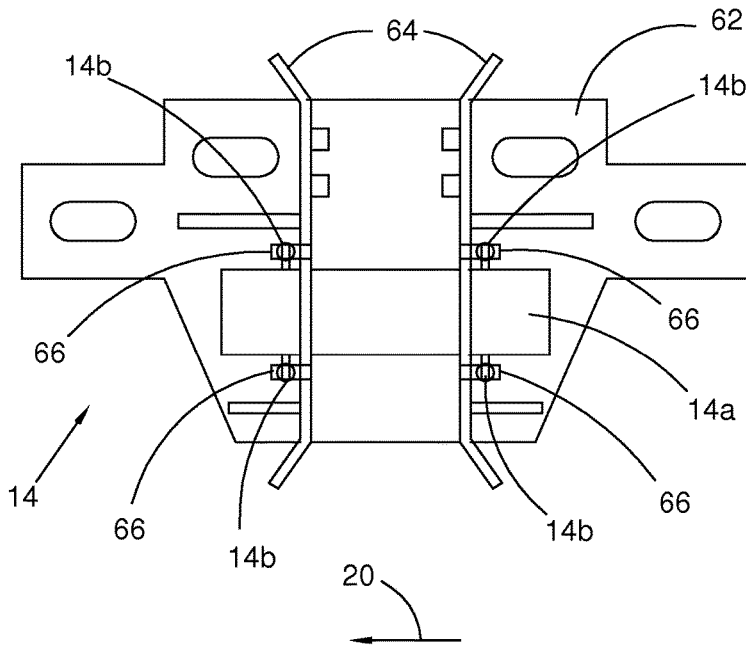

Fig. 5

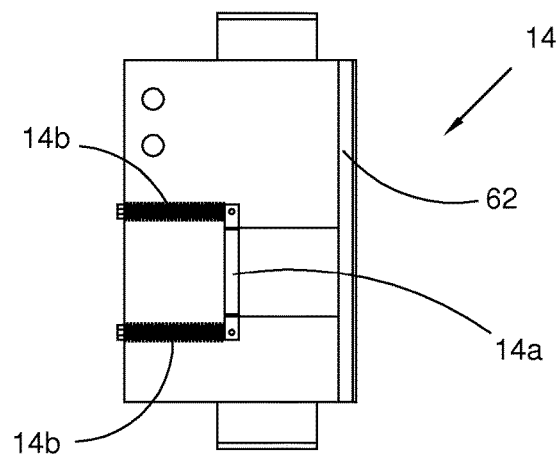

Fig. 6

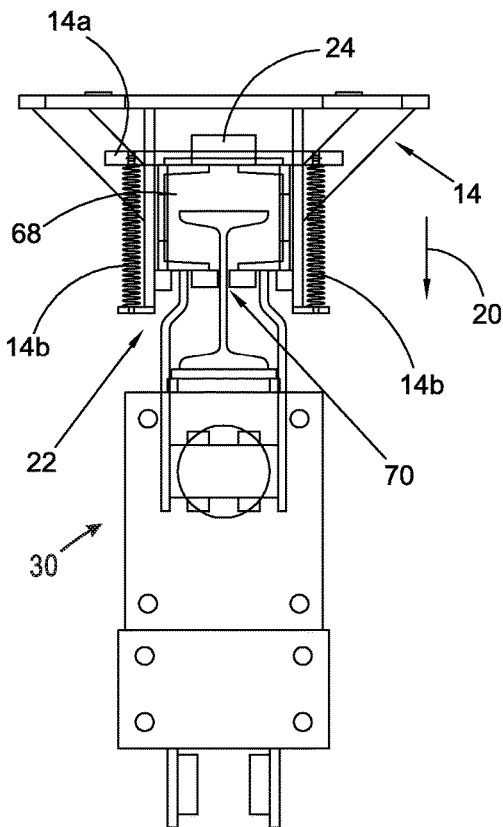

Fig. 7

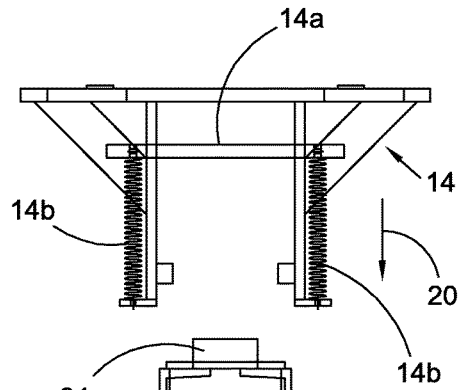

Fig. 8

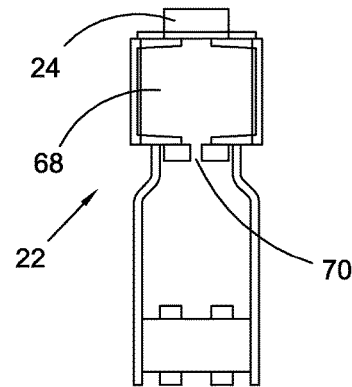

Fig. 9

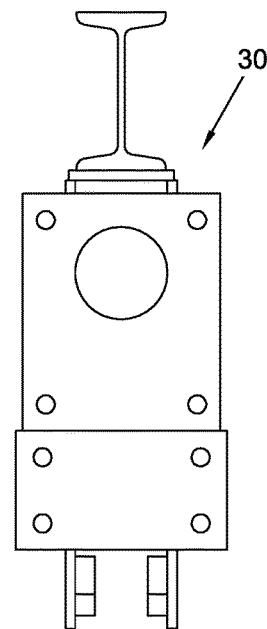

Fig. 10

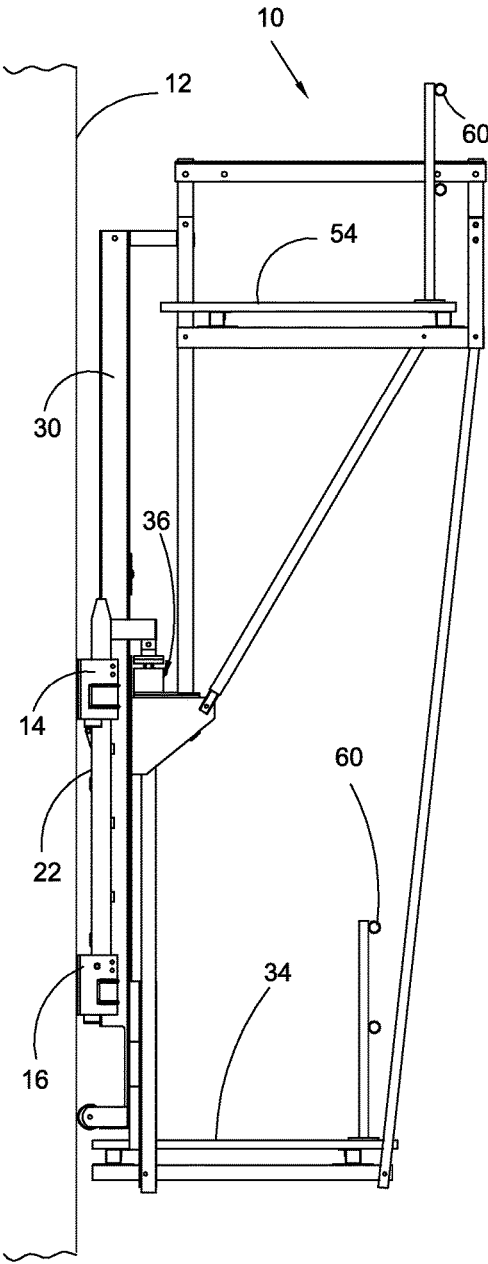

Fig. 11

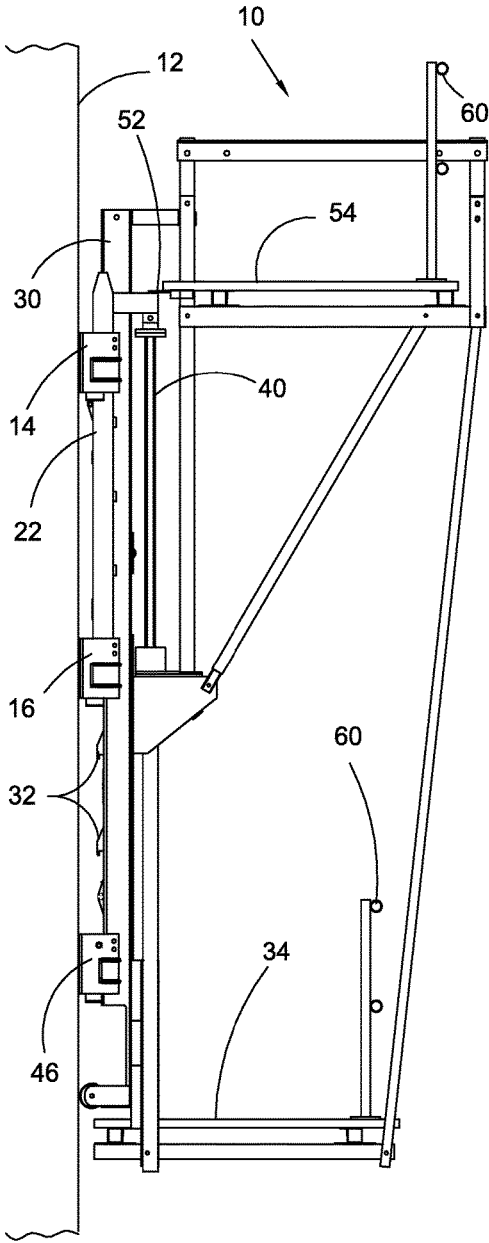

Fig. 12

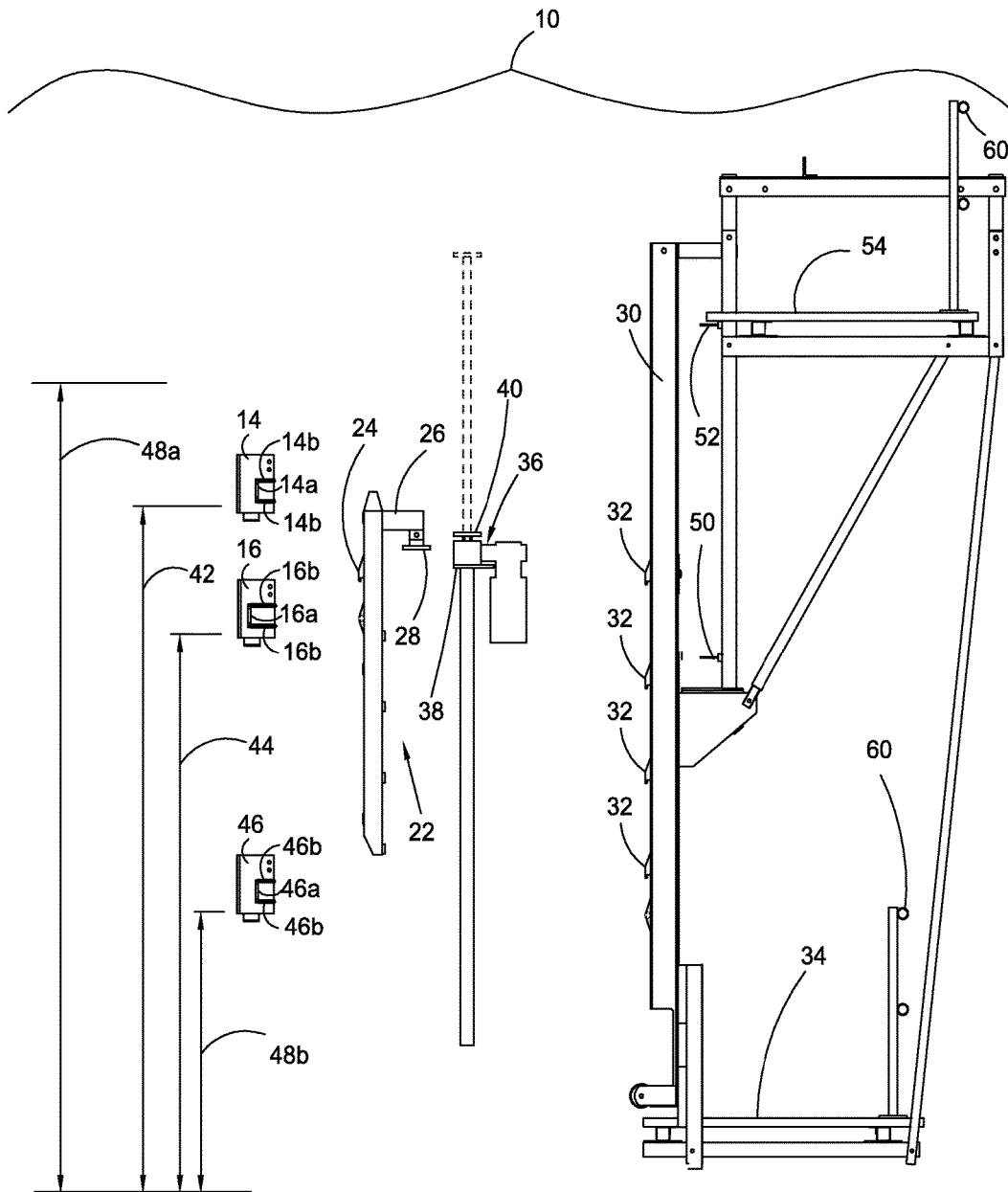

Fig. 13

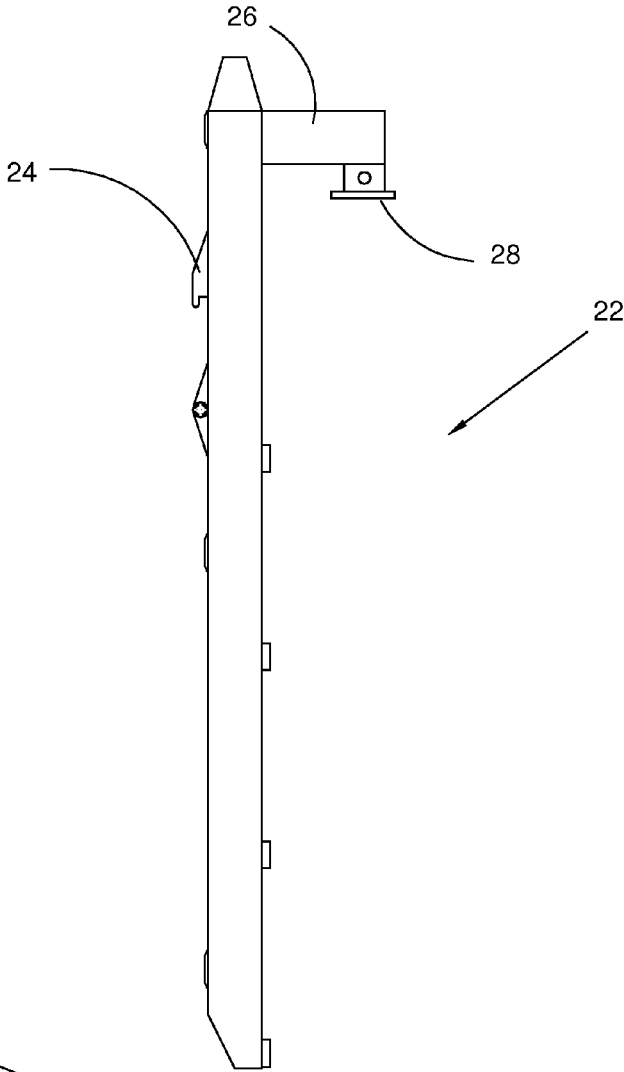

Fig. 14

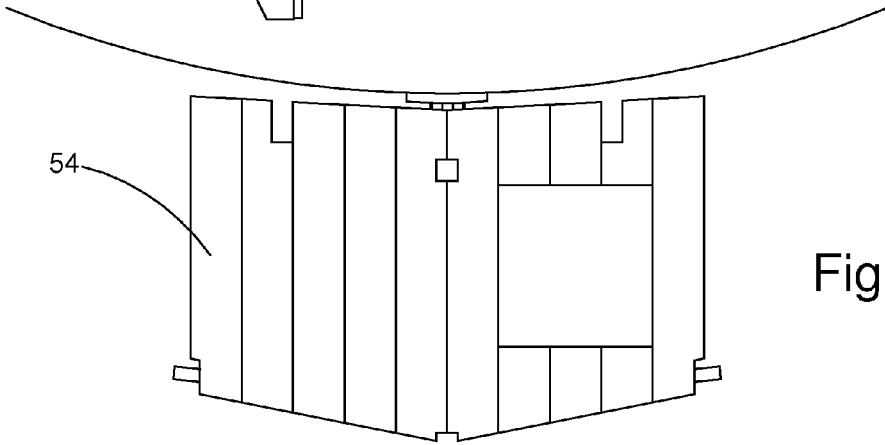

Fig. 15

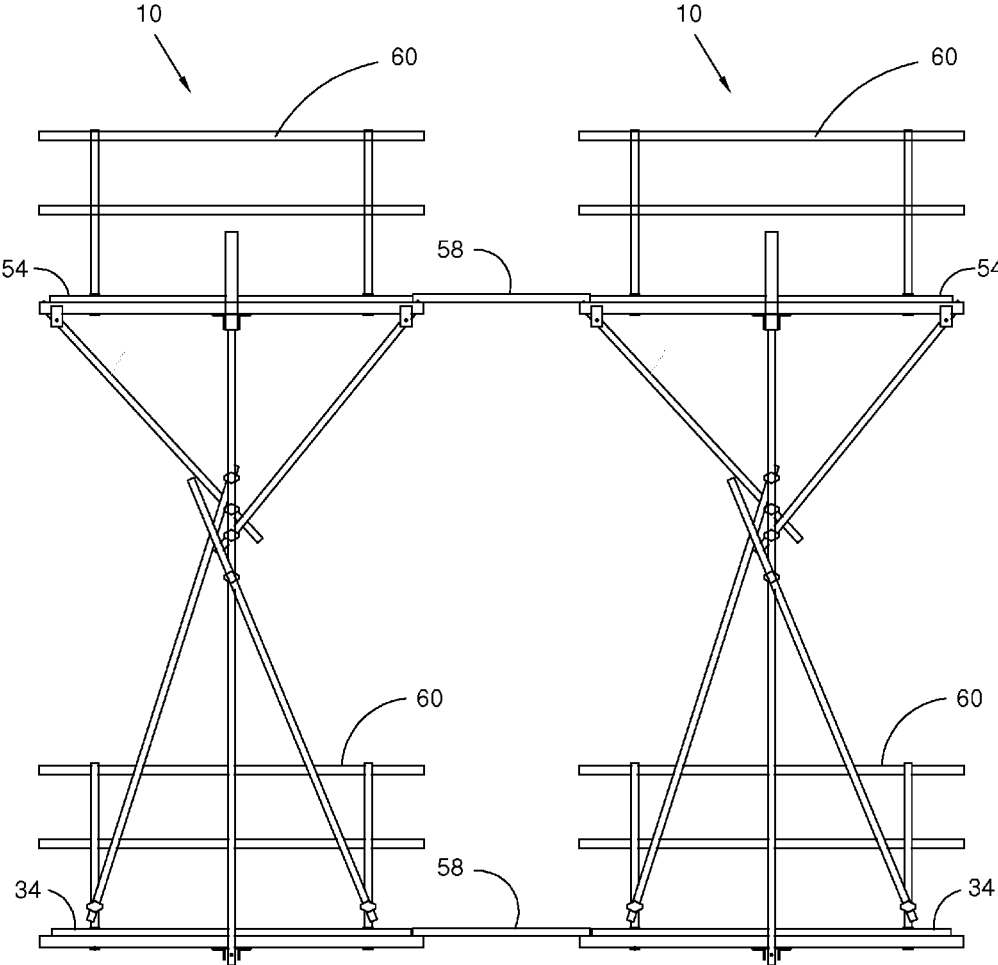

Fig. 16

1

SCAFFOLD SYSTEM

FIELD OF THE INVENTION

The invention broadly relates to scaffold systems, more specifically to a height adjustable scaffold system, and even more particularly to a height adjustable scaffold system adapted to be repositionable throughout its range of use along the full height of a structure.

BACKGROUND OF THE INVENTION

Scaffold systems are often assembled as static structures. For example, ground based scaffolds and scaffolds securely affixed to the side of a structure are commonly used for construction and demolition work. Such structures must be at least partially disassembled in order to be moved to a different location, e.g., height, or in the alternatively, additionally elements, e.g., frames, must be added to the original structure in order to increase the overall height. Changes of this type are time consuming and may require multiple people to assist with the process to ensure a safe transition. Moreover, forming extremely large scaffold structures requires a large number of frames and boards thereby increasing the cost of building the structure.

Some scaffold systems may be moved vertically through the use of complex pulley and motor systems. For example, window washing scaffolds are mounted from a crane like apparatus on the roof of a building via cables connecting the scaffold to the crane motor. The height of the scaffold is altered by activating the crane thereby causing the scaffold to raise or lower. Such arrangements require the mounting of an additional apparatus, i.e., a crane, and further require clear paths for cables to extend from the crane to the scaffold. Other systems use hydraulic cylinders to move a scaffold up or down. Hydraulic cylinders require a hydraulic power pack, and a hydraulic power pack is bulky and reduces the load capacity of the scaffold. Moreover, such power packs are electronically powered.

As can be derived from the variety of devices and methods directed to securing a scaffold and subsequently altering its position, many means have been contemplated to accomplish the desired end, i.e., safe, controlled movement a scaffold. Heretofore, tradeoffs between complexity, cost and range of motion were required. Thus, there is a long-felt need for a scaffold that minimizes the number of components needed to alter the position of the scaffold while maintaining the necessary safety of the structure.

BRIEF SUMMARY OF THE INVENTION

The present invention broadly comprises a scaffold system adapted for securing to a structure and for vertical movement relative to the structure. The scaffold system includes first and second wall mounts, each of the wall mounts having a bar and at least one spring biasing the bar in a first direction, a slide post having a slide hook, a slide arm and a hanging pad secured to the slide arm, the slide post arranged for vertical axial movement within at least one of the first and second wall mounts, a main post having at least one post hook, a first deck fixedly secured to the main post, and a ball screw jack having a mounting plate and a lifting screw, the mounting plate secured to the first deck and the lifting screw secured to the hanging pad. The main post is arranged to complementarily fit within slide post, the slide hook is adapted for releasable engagement with the first wall mount bar or the second wall mount bar and the at least one

2

post hook is adapted for releasable engagement with the first wall mount bar or the second wall mount bar.

In an embodiment, the first wall mount is secured to the structure at a first height, the second wall mount is secured to the structure at a second height elevationally lower than the first height and the slide hook is releasably engaged with the first wall mount bar. In an embodiment, the first wall mount is secured to the structure at a first height, the second wall mount is secured to the structure at a second height elevationally lower than the first height and the at least one post hook is releasably engaged with the second wall mount bar. In an embodiment, the first wall mount is secured to the structure at a first height, the second wall mount is secured to the structure at a second height elevationally lower than the first height, the slide hook is releasably engaged with the first wall mount bar and the at least one post hook is releasably engaged with the second wall mount bar.

In an embodiment, the scaffold system further includes a third wall mount having a bar and at least one spring biasing the bar in a first direction, wherein the first wall mount is secured to the structure at a first height, the second wall mount is secured to the structure at a second height elevationally lower than the first height, the third wall mount is secured to the structure at a third height elevationally lower than the second height and the slide hook is releasably engaged with the first wall mount bar and the at least one post hook is releasably engaged with the third wall mount bar. In an embodiment, the scaffold system further includes a third wall mount having a bar and at least one spring biasing the bar in a first direction, wherein the first wall mount is secured to the structure at a first height, the second wall mount is secured to the structure at a second height elevationally lower than the first height, the third wall mount is secured to the structure at a third height elevationally higher than the first height and the slide hook is releasably engaged with the third wall mount bar and the at least one post hook is releasably engaged with the first wall mount bar or the second wall mount bar.

In an embodiment, the scaffold system further includes at least one limit switch arranged to engage the hanging pad or the slide arm. In an embodiment, the scaffold system further includes a second deck positioned elevationally higher than the first deck. In an embodiment, the scaffold system further includes at least one safety lug secured to the structure and the first deck.

The present invention further broadly comprises a method of modifying the height of a scaffold system mounted on a structure. The scaffold system includes first and second wall mounts, a slide post having a slide hook, a slide arm and a hanging pad secured to the slide arm, a main post having at least one post hook, a first deck fixedly secured to the main post, and a ball screw jack having a mounting plate and a lifting screw. Each of the wall mounts includes a bar and at least one spring biasing the bar in a first direction, the slide post is arranged for vertical axial movement within at least one of the first and second wall mounts, the mounting plate is secured to the first deck, the lifting screw is secured to the hanging pad, the main post is arranged to complementarily fit within slide post, the slide hook is adapted for releasable engagement with the first wall mount bar or the second wall mount bar and the at least one post hook is adapted for releasable engagement with the first wall mount bar or the second wall mount bar. The method includes: a) securing the first wall mount to the structure at a first height and securing the second wall mount to the structure at a second height elevationally lower than the first height; b) releasably engaging the at least one post hook with the second wall mount

3

bar; c) releasably engaging the slide hook with the first wall mount bar; d) securing a third wall mount to the structure at a third height elevationally higher the first height, the third wall mount includes a bar and at least one spring biasing the bar in a first direction; e) energizing the ball screw jack, wherein the ball screw jack extends the lifting screw thereby increasing a vertical height of the slide post; f) releasably engaging the slide hook with the third wall mount bar; g) energizing the ball screw jack, wherein the ball screw jack retracts the lifting screw thereby increasing the vertical height of the main post; and, h) releasably engaging the at least one post hook with first wall mount bar.

The present invention yet further broadly comprises a method of modifying the height of a scaffold system mounted on a structure. The scaffold system includes first and second wall mounts, a slide post having a slide hook, a slide arm and a hanging pad secured to the slide arm, a main post having at least one post hook, a first deck fixedly secured to the main post, and a ball screw jack having a mounting plate and a lifting screw. Each of the wall mounts includes a bar and at least one spring biasing the bar in a first direction, the slide post is arranged for vertical axial movement within at least one of the first and second wall mounts, the mounting plate is secured to the first deck, the lifting screw is secured to the hanging pad, the main post is arranged to complementarily fit within slide post, the slide hook is adapted for releasable engagement with the first wall mount bar or the second wall mount bar and the at least one post hook is adapted for releasable engagement with the first wall mount bar or the second wall mount bar. The method includes: a) securing the first wall mount to the structure at a first height and securing the second wall mount to the structure at a second height elevationally lower than the first height; b) releasably engaging the at least one post hook with the second wall mount bar; c) releasably engaging the slide hook with the first wall mount bar; d) securing a third wall mount to the structure at a third height elevationally lower the second height, the third wall mount includes a bar and at least one spring biasing the bar in a first direction; e) energizing the ball screw jack, wherein the ball screw jack extends the lifting screw thereby decreasing a vertical height of the main post; f) releasably engaging the at least one post hook with the third wall mount bar; g) energizing the ball screw jack, wherein the ball screw jack retracts the lifting screw thereby decreasing the vertical height of the slide post; and, h) releasably engaging the slide hook with second wall mount bar.

It is a general object of the present invention to provide a moveable scaffold which can alter its vertical position along an entire height of a structure without the need for excessive materials or cost.

It is another general object of the present invention to maintain safety while modifying the position of a scaffold system.

These and other objects and advantages of the present invention will be readily appreciable from the following description of preferred embodiments of the invention and from the accompanying drawings and claims.

BRIEF DESCRIPTION OF THE DRAWINGS

The nature and mode of operation of the present invention will now be more fully described in the following detailed description of the invention taken with the accompanying drawing figures, in which:

4

FIG. 1 is a perspective view of a structure, i.e., a chimney, having an embodiment of a present invention scaffold system secured thereto;

FIG. 2 is a side elevational view of an embodiment of a present invention scaffold system;

FIG. 3 is a front elevational view of an embodiment of a present invention scaffold system;

FIG. 4 is a top plan view of an embodiment of a wall mount;

FIG. 5 is a front elevational view of the wall mount of FIG. 4;

FIG. 6 is a side elevational view of the wall mount of FIG. 4;

FIG. 7 is a top plan view of an embodiment of a main post within a slide post wherein the slide post is releasably secured to a wall mount;

FIG. 8 is a top plan view of the wall mount of FIG. 7;

FIG. 9 is a top plan view of the slide post of FIG. 7;

FIG. 10 is a top plan view of the main post of FIG. 7;

FIG. 11 is a side elevational view of an embodiment of a present invention scaffold system showing a ball screw jack in a retracted position;

FIG. 12 is a side elevational view of an embodiment of a present invention scaffold system showing a ball screw jack in an extended position;

FIG. 13 is a side elevational exploded view of the embodiment of the scaffold system shown in FIG. 13;

FIG. 14 is a side elevational view of an embodiment of a slide post;

FIG. 15 is a top plan view of an embodiment of an upper deck having an access hole arranged therein; and,

FIG. 16 is a front elevational view of an embodiment of a present invention scaffold system including two adjacent scaffold systems connected by a folding walkway.

DETAILED DESCRIPTION OF THE INVENTION

At the outset, it should be appreciated that like drawing numbers on different drawing views identify identical, or functionally similar, structural elements of the invention. While the present invention is described with respect to what is presently considered to be the preferred aspects, it is to be understood that the invention as claimed is not limited to the disclosed aspects.

Furthermore, it is understood that this invention is not limited to the particular methodology, materials and modifications described and as such may, of course, vary. It is also understood that the terminology used herein is for the purpose of describing particular aspects only, and is not intended to limit the scope of the present invention, which is limited only by the appended claims.

Unless defined otherwise, all technical and scientific terms used herein have the same meaning as commonly understood to one of ordinary skill in the art to which this invention belongs. Although any methods, devices or materials similar or equivalent to those described herein can be used in the practice or testing of the invention, the preferred methods, devices, and materials are now described.

Adverting now to the figures, FIG. 1 shows a perspective view of an embodiment of the present invention scaffold system 10 mounted on chimney 12. The nature and mode of operation of scaffold 10 is best understood in view of FIG. 1 through 15.

Scaffold system 10 is adapted for securing to structure 12, e.g., a chimney, and for vertical movement relative to structure 12. Scaffold system 10 comprises first and second

5

wall mounts **14** and **16**, respectively. Each of wall mounts **14** and **16** comprise a bar, i.e., bars **14a** and **16a**, respectively, and at least one spring, i.e., springs **14b** and **16b**, respectively, which are arranged to bias the bar in a first direction, i.e., the direction depicted by uni-directional arrow **20**. Scaffold system **10** further comprises slide post **22** comprising slide hook **24**, slide arm **26** and hanging pad **28** secured to slide arm **26**. Slide post **22** is arranged for vertical axial movement within at least one of first and second wall mounts **14** and **16**, respectively. Scaffold system **10** further comprises main post **30** comprising post hooks **32** and still yet further comprises first deck **34** fixedly secured to main post **30**. Scaffold system **10** further comprises ball screw jack **36** comprising mounting plate **38** and lifting screw **40**. Mounting plate **38** is secured to first deck **34** and lifting screw **40** is secured to hanging pad **28**. Main post **30** is arranged to complementarily fit within slide post **22**. Slide hook **24** is adapted for releasable engagement with first wall mount bar **14a** or second wall mount bar **16a**, while post hooks **32** are adapted for releasable engagement with first wall mount bar **14a** or the second wall mount bar **16a**.

In an embodiment, first wall mount **14** is secured to structure **12** at a first height, e.g., height **42**, and second wall mount **16** is secured to structure **12** at a second height elevationally lower than the first height, e.g., height **44**. In an embodiment, slide hook **24** is releasably engaged with first wall mount bar **14a**, while in another embodiment, one of post hooks **32** is releasably engaged with second wall mount bar **16a**, and in yet another embodiment, slide hook **24** is releasably engaged with first wall mount bar **14a** and one of post hooks **32** is releasably engaged with second wall mount bar **16a**.

In an embodiment, ball screw jack **36** is a 10-ton ball screw jack. The jack is powered with a 220 volt single phase motor, and is equipped with a brake and pendant cord with an up-and-down switch to control the scaffold movement. Existing power cords are utilized to energize ball screw jack **36**.

In an embodiment, scaffold system **10** further comprises third wall mount **46** comprising a bar, i.e., bar **46a**, and at least one spring, i.e., springs **46b**. Springs **46b** bias bar **46a** in a first direction, i.e., the direction depicted by uni-directional arrow **20**. In an embodiment, third wall mount **46** is secured to structure **12** at a third height elevationally lower than second height **44**, e.g., height **48b**. In an embodiment, slide hook **24** is releasably engaged with first wall mount bar **14a** and post hook **32** is releasably engaged with third wall mount bar **46a**. Additional embodiments are described below. For example, embodiments are set forth below where third wall mount **46** is secured to structure **12** at a third height elevationally higher than first height **42**, e.g., height **48a** (as shown in FIG. **13**).

In an embodiment, scaffold system **10** further comprises at least one limit switch, e.g., limit switches **50** and **52**, arranged to engage hanging pad **28** when ball screw jack **36** is moving in a direction to retract lifting screw **40** or to engage slide arm **26** when ball screw jack **36** is moving in a direction to extend lifting screw **40**. In view of the foregoing, it should be appreciated that limit switches provide feedback to the system regarding the position of ball screw jack **36**, e.g., reaching its full extension or full retraction, thereby preventing damage to ball screw jack **36** and failure of scaffold system **10** by automatically stopping travel of the lifting mechanism. It should be further appreciated that a single limit switch may be used thereby detecting the position of ball screw jack **36** in a single location. Moreover, greater than two limit switches may be

6

included thereby providing more detailed position information. The limit switch or switches are an added safety factor which helps eliminate human error.

In an embodiment, scaffold system **10** further comprises second deck **54** positioned elevationally higher than first deck **34**. The arrangement of decks included with scaffold system **10** depends upon the needs of the user. For example, two levels may be needed, e.g., a first lower level for finish assembly work and a second upper level for preparation work. One of ordinary skill in the art will appreciate that more than two decks may also be included, e.g., three, and that the number of decks is limited by the structure of the scaffold and the size of the ball screw jack, e.g., 10-ton, 20-ton, etc., and such variations fall within the scope of the claims. In an embodiment, the upper working deck is eliminated from the scaffold when it is used as a demolition scaffold. The main support tubes of scaffold system **10** have been modified to allow the upper deck to be added as required for different job specific requirements, such as repair work.

As safety is critical with such structures, e.g., scaffolds may be mounted hundreds of feet above the ground, scaffold system **10** may include further safety features. For example, scaffold system **10** may comprise at least one safety lug, e.g., lug **56**, secured to structure **12** and first deck **34**. Safety lug **56** is anchored into structure **12**. Lug **56** is then connected to individual scaffold sections with a steel choker and secured to the scaffold with a safety shackle secured at the top working deck. Lug **56** helps ensure the scaffold sections are secured to structure **12**.

Furthermore, scaffold system **10** may include other safety equipment incorporated to maintain a safe working environment. In an embodiment, the scaffold system may be equipped with folding walkway **58** extending between adjacent scaffold systems (See FIG. **16**), wherein the walkway minimizes or eliminates a tripping hazard as a user walks from one scaffold section to an adjacent scaffold section. Such safety equipment is essential when the scaffold systems are moving up or down. Moreover, the scaffold system may include hand rails **60**, and at each open end of a deck, hand rails **60** may be equipped with a self-closing gate. The foregoing gates help secure the open ends of a deck thereby minimizing or eliminating fall hazards. The nature and mode of operation of such gates are well known to one having ordinary skill in the art.

First, second and third wall mounts **14**, **16** and **46**, respectively, share a similar structural arrangement. The structure of first wall mount **14** is described in detail herein. As each wall mount is configured in the same fashion, the description herein is applicable second and third wall mounts **16** and **46**, respectively. Wall mount **14** comprises mounting plate **62** and side plates **64** extending therefrom. Side plates **64** comprise flanges **66**. Springs **14b** extend between flanges **66** and mount bar **14a**. Springs **14b** bias mount bar **14a** in the direction of uni-directional arrow **20**, thereby biasing mount bar **14a** away from mounting plate **62**. As mount bar **14a** is actuated towards mounting plate **62**, a load is applied to springs **14b**. After removal of the load, springs **14b** return mount bar **14a** to its rest position. In view of the foregoing, it should be appreciated that a load is applied to mount bar **14a** during each instance of a hook, e.g., slide hook **24** and post hooks **32**, passing by mount bar **14a**. Moreover, in order to release a hook from a mount bar so that slide post **22** or main post **30** may pass by the mount bar, a load must be applied to mount bar **14a** in a direction opposite than uni-directional arrow **20**, for example, by an operator.

Slide post **22** and main post **30** are arranged in a nested relationship. The nested arrangement is described herein. In order to permit the free movement of slide post **22** relative to main post **30**, main post **30** is positioned partially within opening **68** and moves vertically within opening **68** and slot **70**. Embodiments using the foregoing arrangement are set forth herebelow.

The nature of the operation of the present invention scaffold system will now be more fully explained. The operation differs depending upon the direction of movement, i.e., upwardly or downwardly. First, upward movement of scaffold system **10** is discussed.

In order to move scaffold system **10** upwardly, first wall mount **14** is secured to structure **12** at height **42** and second wall mount **16** is secured to structure **12** at height **44**. Post hook **32** is releasably engaged with second wall mount bar **16a**, while slide hook **24** is releasably engaged with first wall mount bar **14a**. Next, third wall mount **46** is secured to structure **12** at height **48a**, i.e., elevationally higher than first height **42** (as shown in FIG. **13**). Then, ball screw jack **36** is energized causing ball screw jack **36** to extend lifting screw **40** thereby increasing the vertical height of slide post **22**. The actuation of ball screw jack **36** releasably engaged slide hook **24** with third wall mount bar **46a**. Next, ball screw jack **36** is energized causing ball screw jack **36** to retract lifting screw **40** thereby increasing the vertical height of main post **30**. The actuation of ball screw jack **36** releasably engaged post hook **32** with first wall mount bar **14a**.

Alternatively, scaffold system **10** may be used to move down a structure. The following describes the steps of moving the scaffold in a downward direction. Similar to the method described above, first wall mount **14** is secured to structure **12** at height **42** and second wall mount **16** is secured to structure **12** at height **44**. Post hook **32** is releasably engaged with second wall mount bar **16a**, while slide hook **24** is releasably engaged with first wall mount bar **14a**. Next, third wall mount **46** is secured to structure **12** at height **48b**, i.e., elevationally lower than second height **44**. Then, ball screw jack **36** is energized causing ball screw jack **36** to extend lifting screw **40** thereby decreasing the vertical height of main post **30**. The actuation of ball screw jack **36** releasably engages post hook **32** with third wall mount bar **46a**. Next, ball screw jack **36** is energized causing ball screw jack **36** to retract lifting screw **40** thereby decreasing the vertical height of slide post **22**. The actuation of ball screw jack **36** releasably engaged slide hook **24** with second wall mount bar **16a**.

The present invention includes other features which increase its safety, utility and effectiveness. For example, main post **30** may include elevations marked at various increments, e.g., six inch increments, which assist in keeping the entire system, i.e., multiple adjacent scaffold systems **10**, at the same elevations. Moreover, such markings provide an operator feedback regarding how much travel remains on lifting screw **40**. Still further, in an embodiment, the lower work deck, which is used to operate scaffold system **10**, is modified to allow access from an exterior elevator and ladder system. Even yet further, in an embodiment, scaffold system **10** may be fitted with a separate hoist to transport equipment and materials to the work area.

Thus, it is seen that the objects of the present invention are efficiently obtained, although modifications and changes to the invention should be readily apparent to those having ordinary skill in the art, which modifications are intended to be within the spirit and scope of the invention as claimed. It also is understood that the foregoing description is illustrative of the present invention and should not be considered as

limiting. Therefore, other embodiments of the present invention are possible without departing from the spirit and scope of the present invention.

What I claim is:

1. A scaffold system adapted for securing to a structure and for vertical movement relative to the structure, the scaffold system comprising:

first and second wall mounts, each of the wall mounts comprising a bar and at least one spring biasing the bar in a first direction;

a slide post comprising a slide hook, a slide arm and a hanging pad secured to the slide arm, the slide post arranged for vertical axial movement within at least one of the first and second wall mounts;

a main post comprising at least one post hook;

a first deck fixedly secured to the main post; and,

a ball screw jack comprising a mounting plate and a lifting screw, the mounting plate secured to the first deck and the lifting screw secured to the hanging pad, wherein when said ball screw jack is powered said lifting screw causes the entire slide post to move upward at the same rate as the lifting screw, wherein the main post is arranged to complementarily fit within the slide post, the slide hook is adapted for releasable engagement with the first wall mount bar or the second wall mount bar and the at least one post hook is adapted for releasable engagement with the first wall mount bar or the second wall mount bar.

2. The scaffold system of claim **1** wherein the first wall mount is secured to the structure at a first height, the second wall mount is secured to the structure at a second height elevationally lower than the first height and the slide hook is releasably engaged with the first wall mount bar.

3. The scaffold system of claim **1** wherein the first wall mount is secured to the structure at a first height, the second wall mount is secured to the structure at a second height elevationally lower than the first height and the at least one post hook is releasably engaged with the second wall mount bar.

4. The scaffold system of claim **1** wherein the first wall mount is secured to the structure at a first height, the second wall mount is secured to the structure at a second height elevationally lower than the first height, the slide hook is releasably engaged with the first wall mount bar and the at least one post hook is releasably engaged with the second wall mount bar.

5. The scaffold system of claim **1** further comprising a third wall mount comprising a bar and at least one spring biasing the bar in a first direction, wherein the first wall mount is secured to the structure at a first height, the second wall mount is secured to the structure at a second height elevationally lower than the first height, the third wall mount is secured to the structure at a third height elevationally lower than the second height and the slide hook is releasably engaged with the first wall mount bar and the at least one post hook is releasably engaged with the third wall mount bar.

6. The scaffold system of claim **1** further comprising a third wall mount comprising a bar and at least one spring biasing the bar in a first direction, wherein the first wall mount is secured to the structure at a first height, the second wall mount is secured to the structure at a second height elevationally lower than the first height, the third wall mount is secured to the structure at a third height elevationally higher than the first height and the slide hook is releasably engaged with the third wall mount bar and the at least one

post hook is releasably engaged with the first wall mount bar or the second wall mount bar.

7. The scaffold system of claim 1 further comprising at least one limit switch arranged to engage the hanging pad or the slide arm.

8. The scaffold system of claim 1 further comprising a second deck positioned elevationally higher than the first deck.

9. The scaffold system of claim 1 further comprising at least one safety lug secured to the structure and the first deck.

10. A method of modifying the height of a scaffold system mounted on a structure, the scaffold system comprising first and second wall mounts, a slide post comprising a slide hook, a slide arm and a hanging pad secured to the slide arm, a main post comprising at least one post hook, a first deck fixedly secured to the main post, and a ball screw jack comprising a mounting plate and a lifting screw, wherein each of the wall mounts comprises a bar and at least one spring biasing the bar in a first direction, the slide post is arranged for vertical axial movement within at least one of the first and second wall mounts, the mounting plate is secured to the first deck, the lifting screw is secured to the hanging pad, the main post is arranged to complementarily fit within the slide post, the slide hook is adapted for releasable engagement with the first wall mount bar or the second wall mount bar and the at least one post hook is adapted for releasable engagement with the first wall mount bar or the second wall mount bar, the method comprising:

- a) securing the first wall mount to the structure at a first height and securing the second wall mount to the structure at a second height elevationally lower than the first height;
- b) releasably engaging the at least one post hook with the second wall mount bar;
- c) releasably engaging the slide hook with the first wall mount bar;
- d) securing a third wall mount to the structure at a third height elevationally higher the first height, the third wall mount comprises a bar and at least one spring biasing the bar in a first direction;
- e) energizing the ball screw jack, wherein the ball screw jack extends the lifting screw thereby increasing a vertical height of the slide post;
- f) releasably engaging the slide hook with the third wall mount bar;

g) energizing the ball screw jack, wherein the ball screw jack retracts the lifting screw thereby increasing the vertical height of the main post; and,

h) releasably engaging the at least one post hook with first wall mount bar.

11. A method of modifying the height of a scaffold system mounted on a structure, the scaffold system comprising first and second wall mounts, a slide post comprising a slide hook, a slide arm and a hanging pad secured to the slide arm, a main post comprising at least one post hook, a first deck fixedly secured to the main post, and a ball screw jack comprising a mounting plate and a lifting screw, wherein each of the wall mounts comprises a bar and at least one spring biasing the bar in a first direction, the slide post is arranged for vertical axial movement within at least one of the first and second wall mounts, the mounting plate is secured to the first deck, the lifting screw is secured to the hanging pad, the main post is arranged to complementarily fit within the slide post, the slide hook is adapted for releasable engagement with the first wall mount bar or the second wall mount bar and the at least one post hook is adapted for releasable engagement with the first wall mount bar or the second wall mount bar, the method comprising:

- a) securing the first wall mount to the structure at a first height and securing the second wall mount to the structure at a second height elevationally lower than the first height;
- b) releasably engaging the at least one post hook with the second wall mount bar;
- c) releasably engaging the slide hook with the first wall mount bar;
- d) securing a third wall mount to the structure at a third height elevationally lower the second height, the third wall mount comprises a bar and at least one spring biasing the bar in a first direction;
- e) energizing the ball screw jack, wherein the ball screw jack extends the lifting screw thereby decreasing a vertical height of the main post;
- f) releasably engaging the at least one post hook with the third wall mount bar;
- g) energizing the ball screw jack, wherein the ball screw jack retracts the lifting screw thereby decreasing the vertical height of the slide post; and,
- h) releasably engaging the slide hook with second wall mount bar.

* * * * *