



US010314718B2

(12) **United States Patent**  
**Suddaby**

(10) **Patent No.:** **US 10,314,718 B2**

(45) **Date of Patent:** **Jun. 11, 2019**

(54) **EXPANDABLE INTERVERTEBRAL FUSION IMPLANT**

(71) Applicant: **Loubert S. Suddaby**, Orchard Park, NY (US)

(72) Inventor: **Loubert S. Suddaby**, Orchard Park, NY (US)

(\* ) Notice: Subject to any disclaimer, the term of this patent is extended or adjusted under 35 U.S.C. 154(b) by 293 days.

(21) Appl. No.: **15/273,032**

(22) Filed: **Sep. 22, 2016**

(65) **Prior Publication Data**

US 2018/0078384 A1 Mar. 22, 2018

(51) **Int. Cl.**

**A61F 2/44** (2006.01)

**A61F 2/30** (2006.01)

(Continued)

(52) **U.S. Cl.**

CPC ..... **A61F 2/4425** (2013.01); **A61F 2/446** (2013.01); **A61F 2/447** (2013.01); **A61F 2/4455** (2013.01); **A61F 2/4465** (2013.01); **A61F 2002/30224** (2013.01); **A61F 2002/30471** (2013.01); **A61F 2002/30537** (2013.01); **A61F 2002/30538** (2013.01); **A61F 2002/30555** (2013.01);

(Continued)

(58) **Field of Classification Search**

CPC ..... **A61F 2/44**; **A61F 2/4425**; **A61F 2/4455**; **A61F 2/446**; **A61F 2/4465**; **A61F 2/447**; **A61F 2002/4475**

USPC ..... **623/17.11-17.16**  
See application file for complete search history.

(56) **References Cited**

U.S. PATENT DOCUMENTS

5,505,732 A 4/1996 Michelson

5,653,762 A 8/1997 Pisharodi

(Continued)

FOREIGN PATENT DOCUMENTS

WO 2008/011371 1/2008

WO 2009/064787 5/2009

WO 2009/105182 8/2009

OTHER PUBLICATIONS

Sahara AL Expandable Stabilization System; Advertisement flyer; Available from K2M, Inc. Leesburg, Virginia; Published as early as Oct. 20, 2015.

(Continued)

*Primary Examiner* — Eric S Gibson

(74) *Attorney, Agent, or Firm* — Simpson & Simpson, PLLC

(57) **ABSTRACT**

An expandable intervertebral fusion implant including an inferior component, a superior component arranged to telescopingly engage the inferior component, and a port arranged in the inferior or superior component. When a first material is introduced through the port, the inferior and superior components are displaced vertically. Each of the inferior and/or superior components can include telescoping components which allow the inferior and/or superior components to be expanded along the length and/or width of the implant before the inferior and superior components are displaced vertically. The expandable intervertebral fusion implant can be expanded with, and locked in place, hydraulic and/or hardenable material. Alternatively, the expandable intervertebral fusion implant can be expanded using a mechanical implement and then hardenable material can be introduced into the implant to maintain the implant in the expanded position.

**20 Claims, 31 Drawing Sheets**

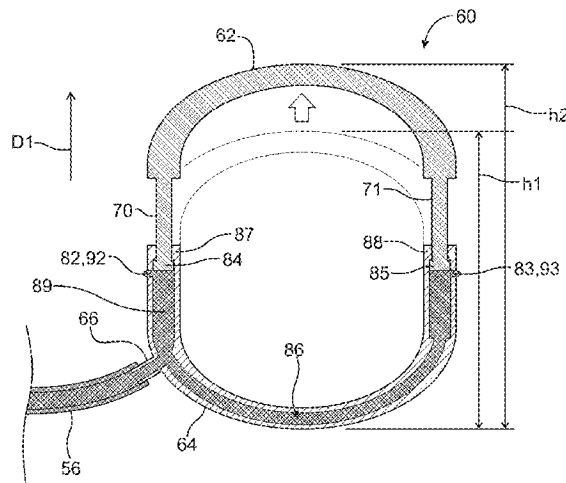
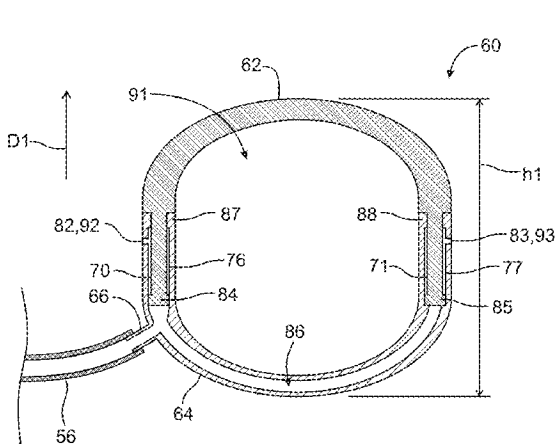

- (51) **Int. Cl.**  
*A61F 2/46* (2006.01)  
*A61F 2/48* (2006.01)
- (52) **U.S. Cl.**  
 CPC ..... *A61F 2002/30556* (2013.01); *A61F 2002/30579* (2013.01); *A61F 2002/30583* (2013.01); *A61F 2002/30593* (2013.01); *A61F 2002/30601* (2013.01); *A61F 2002/30622* (2013.01); *A61F 2002/30693* (2013.01); *A61F 2002/4475* (2013.01); *A61F 2002/4692* (2013.01); *A61F 2002/4693* (2013.01); *A61F 2002/484* (2013.01); *A61F 2002/485* (2013.01)

(56) **References Cited**

U.S. PATENT DOCUMENTS

5,665,122 A 9/1997 Kambin  
 5,683,463 A 11/1997 Godefroy et al.  
 5,827,328 A 10/1998 Buttermann  
 6,176,881 B1 1/2001 Schär et al.  
 6,190,414 B1\* 2/2001 Young ..... A61F 2/447  
 606/247  
 6,395,034 B1 5/2002 Suddaby  
 6,524,341 B2 2/2003 Lång et al.  
 6,837,850 B2 1/2005 Suddaby  
 6,958,077 B2 10/2005 Suddaby  
 6,969,405 B2\* 11/2005 Suddaby ..... A61F 2/441  
 623/17.12  
 6,991,653 B2 1/2006 White et al.  
 7,309,358 B2 12/2007 Berry et al.  
 7,597,714 B2 10/2009 Suddaby  
 7,615,078 B2 11/2009 White et al.  
 7,628,800 B2 12/2009 Sherman et al.  
 7,648,529 B2 1/2010 An et al.  
 7,731,752 B2\* 6/2010 Edie ..... A61F 2/44  
 623/17.11  
 7,794,501 B2\* 9/2010 Edie ..... A61F 2/44  
 623/17.12  
 8,007,535 B2 8/2011 Hudgins et al.  
 8,057,549 B2 11/2011 Butterman et al.  
 8,070,813 B2\* 12/2011 Grotz ..... A61F 2/4465  
 623/17.11  
 8,123,809 B2\* 2/2012 Melkent ..... A61F 2/44  
 623/17.11  
 8,187,328 B2\* 5/2012 Melkent ..... A61F 2/44  
 623/17.11  
 8,246,630 B2 8/2012 Manzi et al.  
 8,273,126 B2 9/2012 Lindner  
 8,303,663 B2 11/2012 Jimenez et al.  
 8,394,143 B2\* 3/2013 Grotz ..... A61F 2/4465  
 623/17.11  
 8,425,611 B2\* 4/2013 Dewey ..... A61F 2/44  
 623/17.12  
 8,435,296 B2\* 5/2013 Kadaba ..... A61F 2/44  
 623/17.12  
 8,480,738 B2 7/2013 Edie et al.  
 8,480,741 B2 7/2013 Grotz et al.  
 8,512,406 B2 8/2013 White et al.  
 8,568,481 B2 10/2013 Olmos et al.  
 8,696,751 B2 4/2014 Ashley et al.  
 8,900,312 B2 12/2014 McLean et al.  
 8,932,302 B2 1/2015 Jimenez et al.  
 8,932,355 B2\* 1/2015 Grotz ..... A61F 2/442  
 623/17.16  
 8,956,413 B2 2/2015 Ashley et al.  
 8,992,620 B2\* 3/2015 Ashley ..... A61F 2/4455  
 623/17.16  
 9,011,499 B1 4/2015 Kiester  
 9,028,550 B2\* 5/2015 Shulock ..... A61F 2/441  
 623/17.11  
 9,066,760 B2 6/2015 Taber et al.  
 9,078,767 B1 7/2015 McLean  
 9,084,686 B1 7/2015 McLean et al.  
 2003/0191531 A1 10/2003 Berry et al.

2004/0102774 A1\* 5/2004 Trieu ..... A61B 17/7097  
 606/86 A  
 2005/0256576 A1\* 11/2005 Moskowitz ..... A61F 2/441  
 623/17.12  
 2007/0093901 A1\* 4/2007 Grotz ..... A61F 2/442  
 623/17.11  
 2007/0233254 A1\* 10/2007 Grotz ..... A61F 2/442  
 623/17.11  
 2007/0250172 A1 10/2007 Moskowitz et al.  
 2007/0255413 A1\* 11/2007 Edie ..... A61F 2/44  
 623/17.16  
 2008/0058930 A1\* 3/2008 Edie ..... A61F 2/44  
 623/17.11  
 2008/0140207 A1 6/2008 Olmos et al.  
 2008/0167726 A1\* 7/2008 Melkent ..... A61F 2/44  
 623/23.48  
 2008/0215153 A1 9/2008 Butterman et al.  
 2009/0182343 A1\* 7/2009 Trudeau ..... A61F 2/4657  
 606/102  
 2009/0216331 A1\* 8/2009 Grotz ..... A61F 2/442  
 623/17.16  
 2009/0270987 A1\* 10/2009 Heinz ..... A61F 2/44  
 623/17.16  
 2010/0004752 A1 1/2010 White et al.  
 2010/0057204 A1\* 3/2010 Kadaba ..... A61F 2/442  
 623/17.12  
 2010/0076559 A1 3/2010 Bagga et al.  
 2010/0114318 A1\* 5/2010 Gittings ..... A61F 2/442  
 623/17.12  
 2010/0198352 A1 8/2010 Edie et al.  
 2010/0204794 A1\* 8/2010 Jarzem ..... A61B 17/8805  
 623/17.12  
 2010/0286783 A1\* 11/2010 Lechmann ..... A61F 2/3094  
 623/17.12  
 2011/0130835 A1\* 6/2011 Ashley ..... A61F 2/442  
 623/17.11  
 2011/0270398 A1\* 11/2011 Grotz ..... A61F 2/442  
 623/17.12  
 2011/0319996 A1\* 12/2011 Barrall ..... A61F 2/442  
 623/17.12  
 2012/0059479 A1 3/2012 Buttermann et al.  
 2012/0101576 A1\* 4/2012 Dewey ..... A61F 2/44  
 623/17.11  
 2012/0116518 A1\* 5/2012 Grotz ..... A61F 2/442  
 623/17.16  
 2012/0271419 A1\* 10/2012 Marik ..... A61F 2/4425  
 623/17.12  
 2013/0131808 A1\* 5/2013 Suh ..... A61F 2/30721  
 623/17.16  
 2013/0190875 A1\* 7/2013 Shulock ..... A61F 2/441  
 623/17.12  
 2013/0231747 A1 9/2013 Olmos et al.  
 2013/0253650 A1\* 9/2013 Ashley ..... A61F 2/4455  
 623/17.16  
 2013/0261748 A1 10/2013 Ashley et al.  
 2014/0012383 A1 1/2014 Triplett et al.  
 2014/0207236 A1 7/2014 Prevost et al.  
 2014/0277476 A1 9/2014 McLean et al.  
 2014/0277480 A1 9/2014 Prevost et al.  
 2015/0012098 A1\* 1/2015 Eastlack ..... A61F 2/447  
 623/17.15  
 2015/0081022 A1 3/2015 McLean et al.  
 2015/0148907 A1 5/2015 Kleiner et al.  
 2015/0289988 A1\* 10/2015 Ashley ..... A61F 2/4455  
 623/17.15  
 2018/0078384 A1\* 3/2018 Suddaby ..... A61F 2/4425

OTHER PUBLICATIONS

Stryker; Stryker AccuLIF® Expandable Lumbar Interbody Fusion Technology; 2014; Product Summary Sheet available from <http://www.stryker.com/en-us/products/Spine/>

(56)

**References Cited**

OTHER PUBLICATIONS

InterbodyVertebralBodyReplacement/Ac-  
cuLIFExpandableLumbarInterbodyFusionTechnology/index.htm.

\* cited by examiner

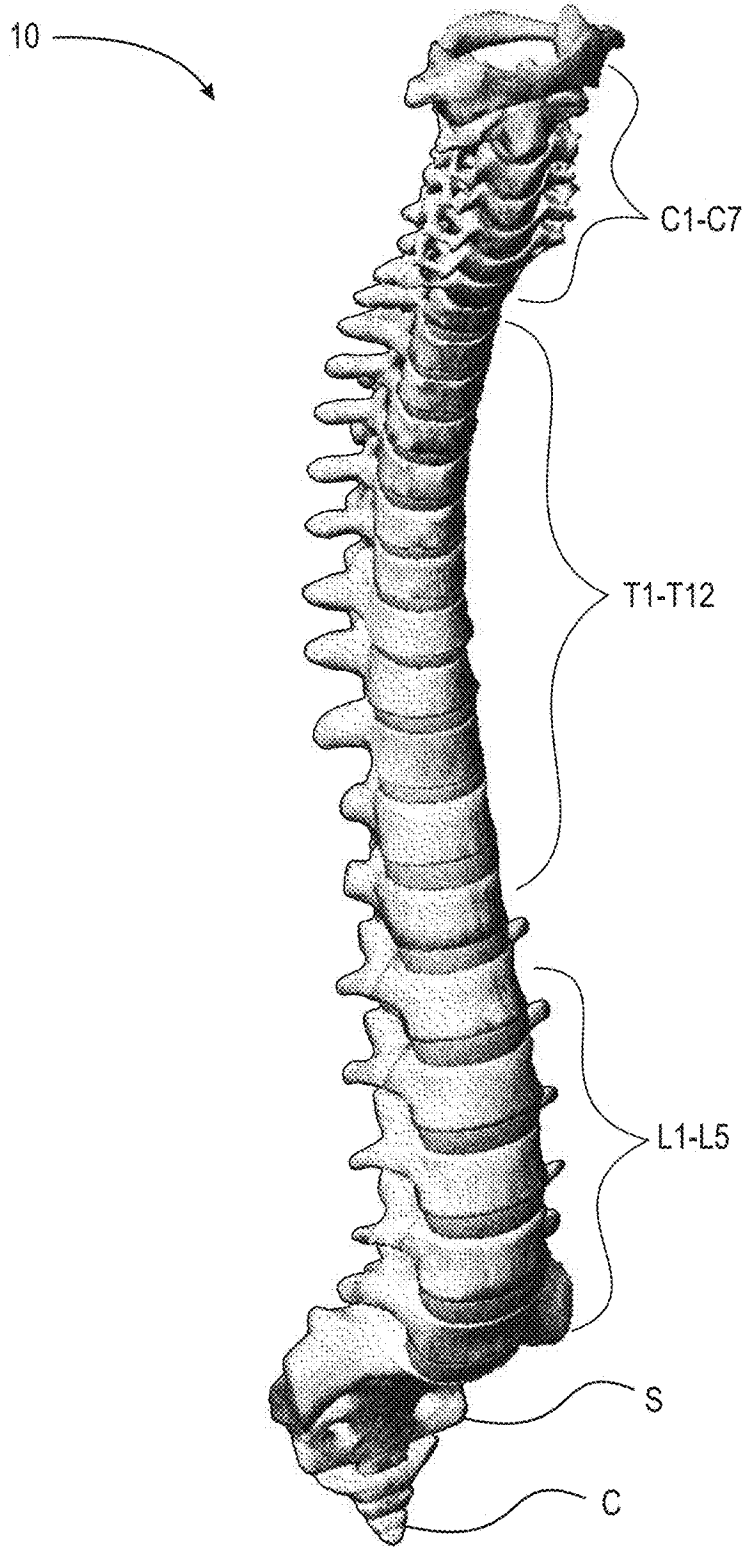

Fig. 1

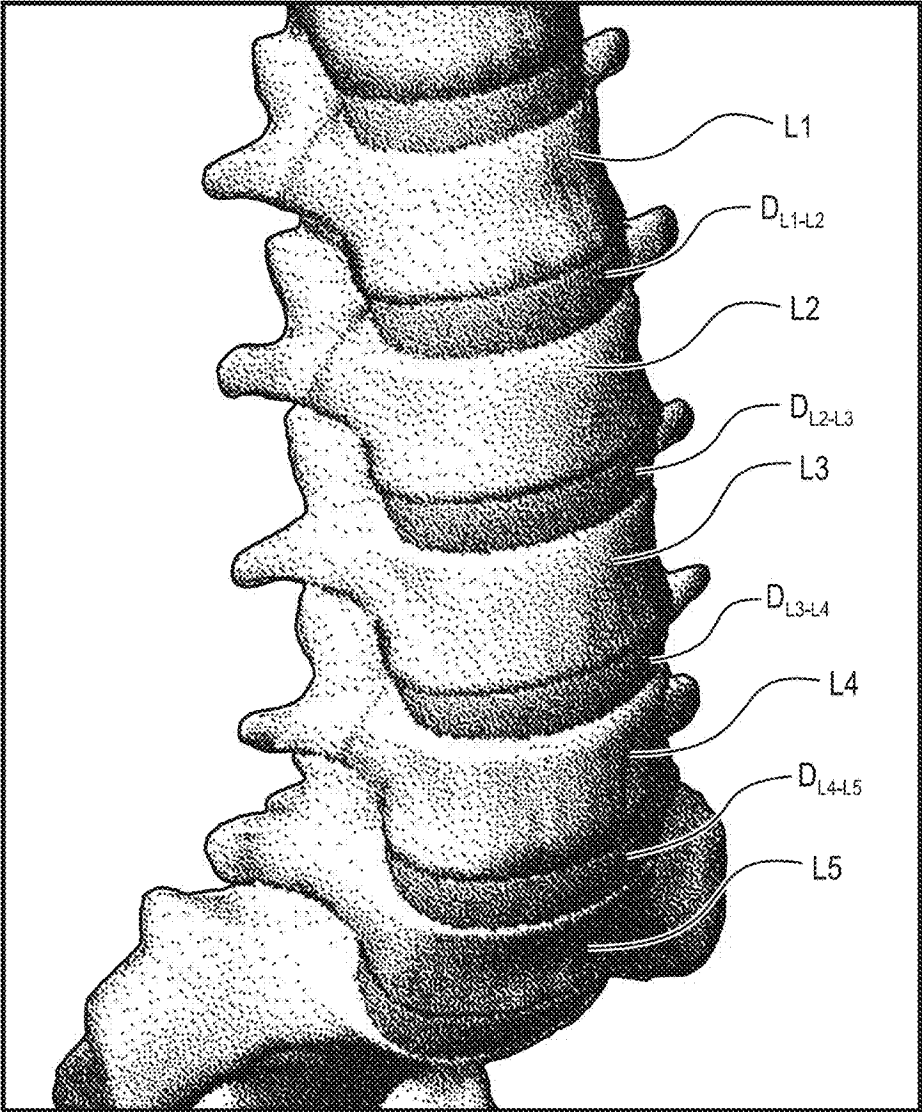

Fig. 2

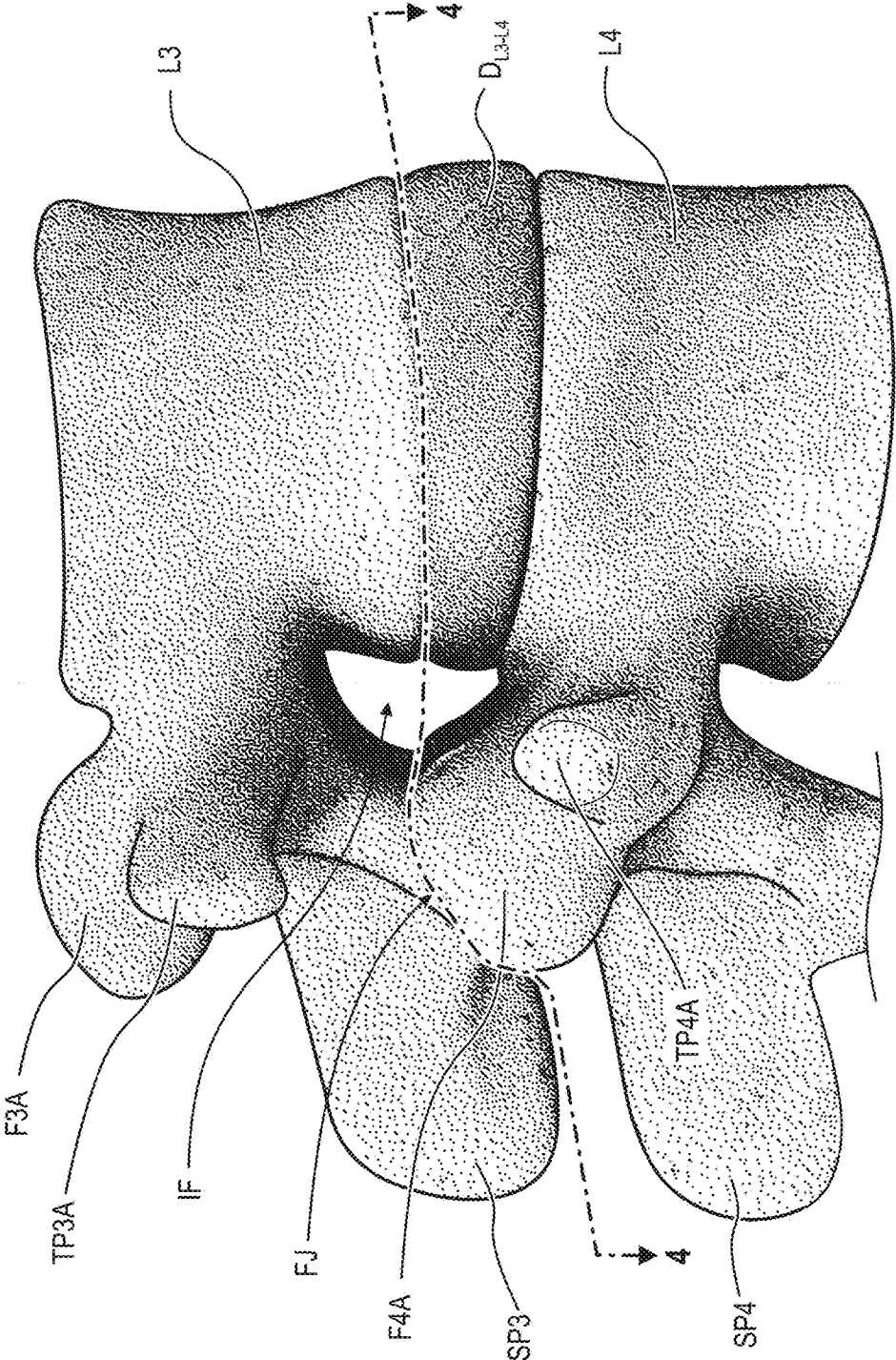

Fig. 3

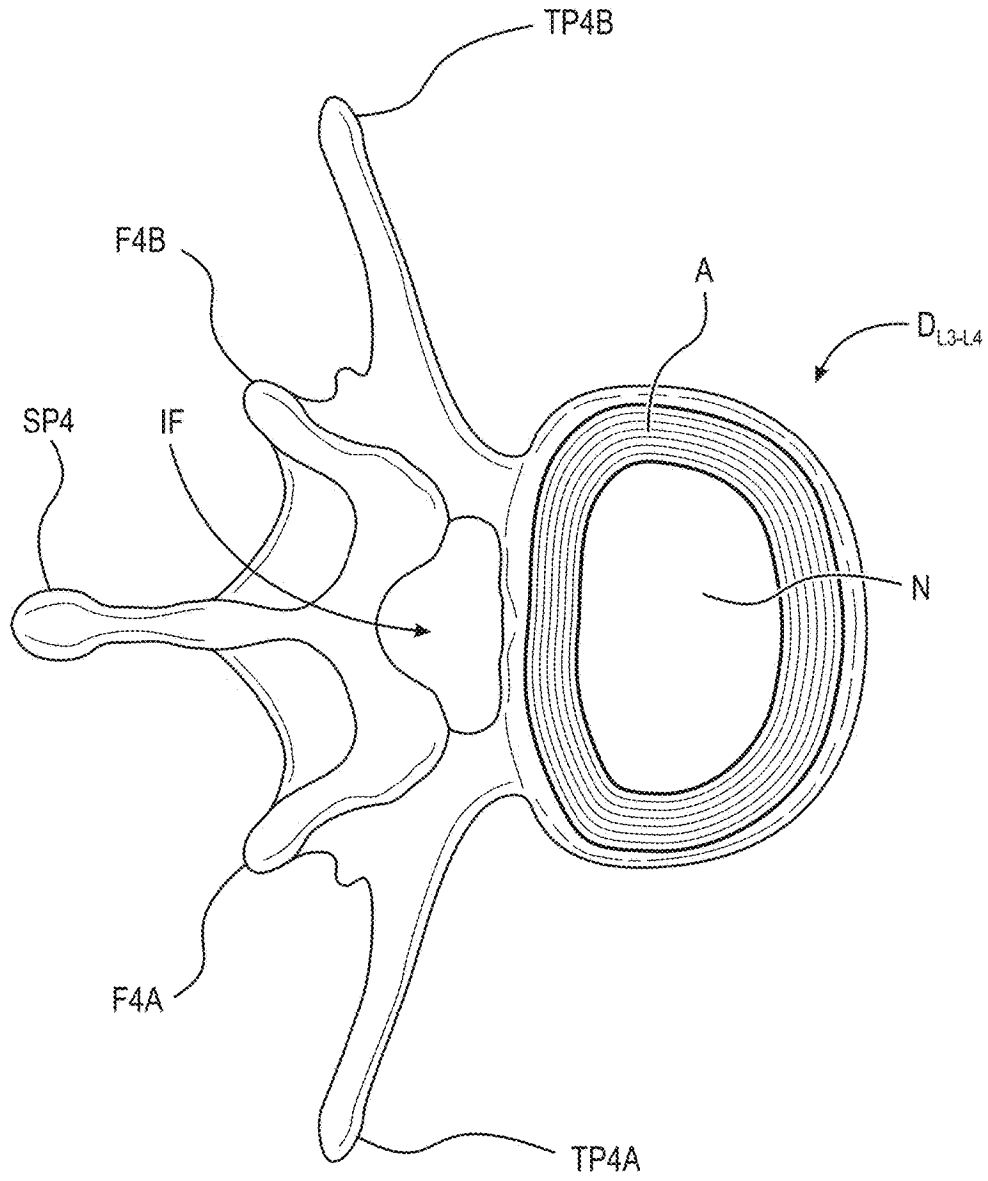

Fig. 4

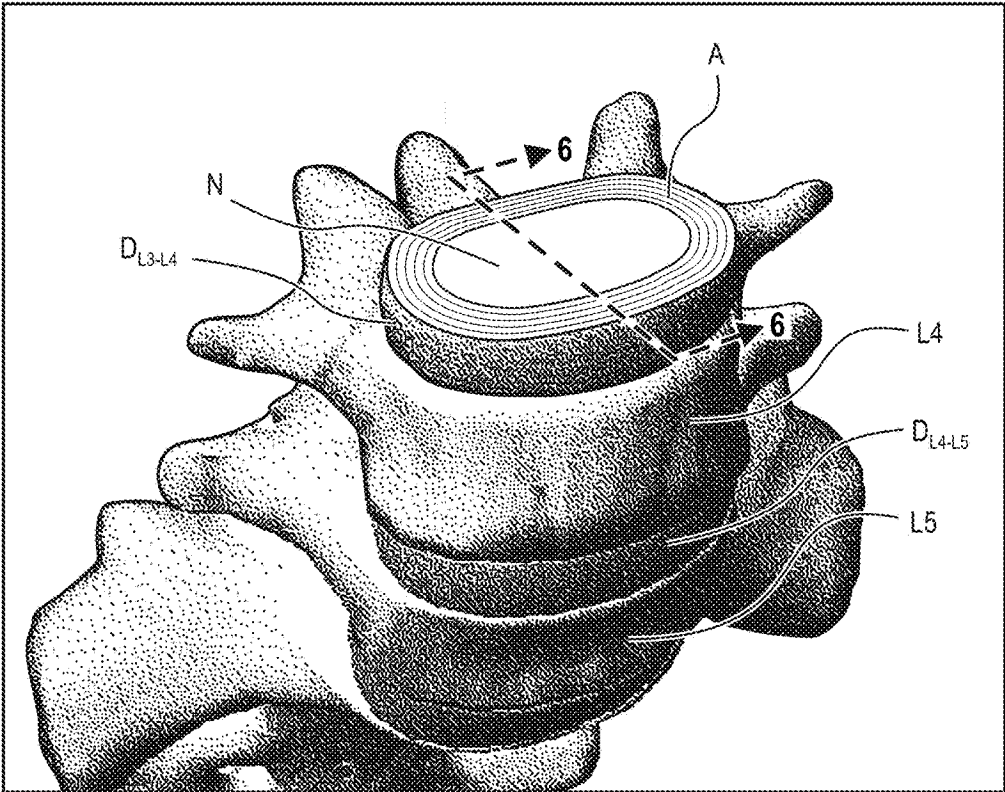

Fig. 5



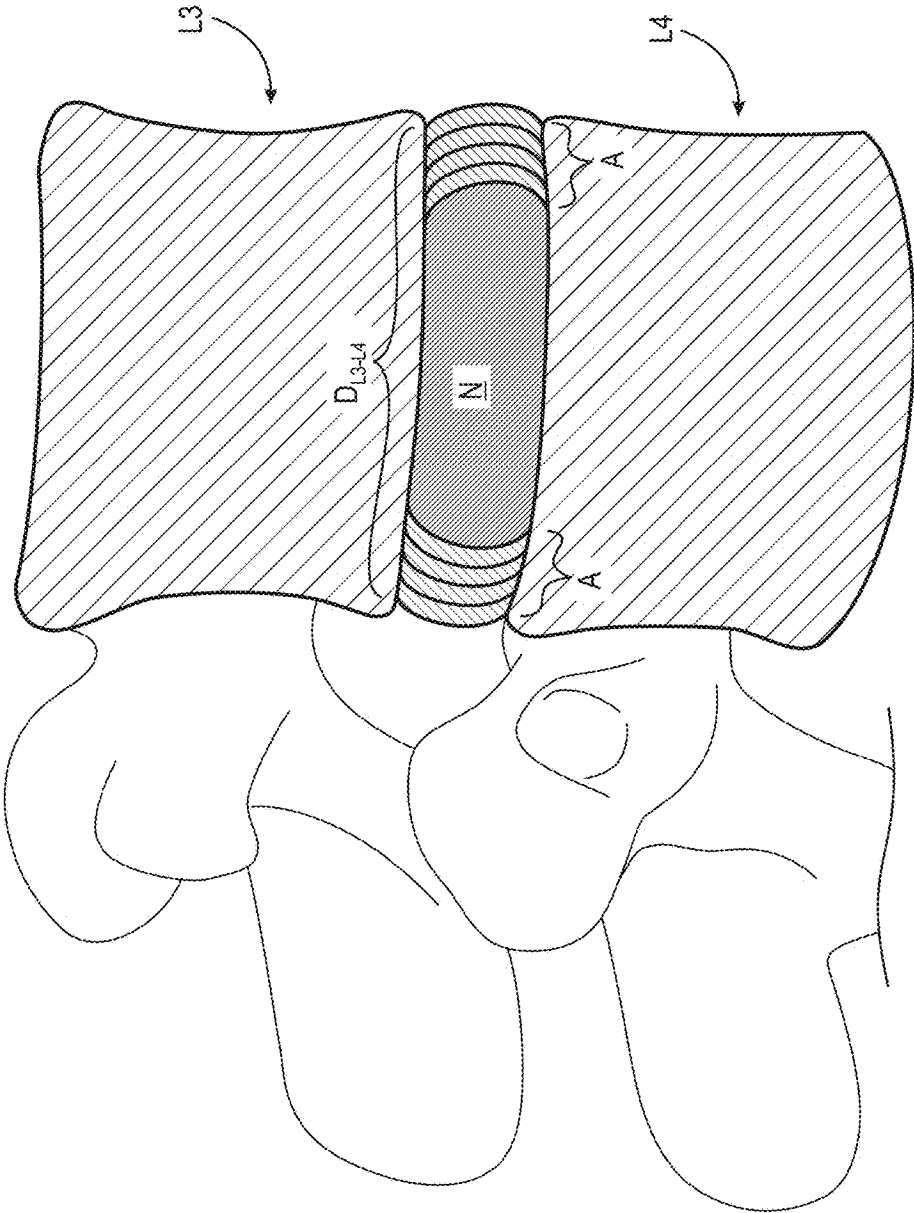

Fig. 6

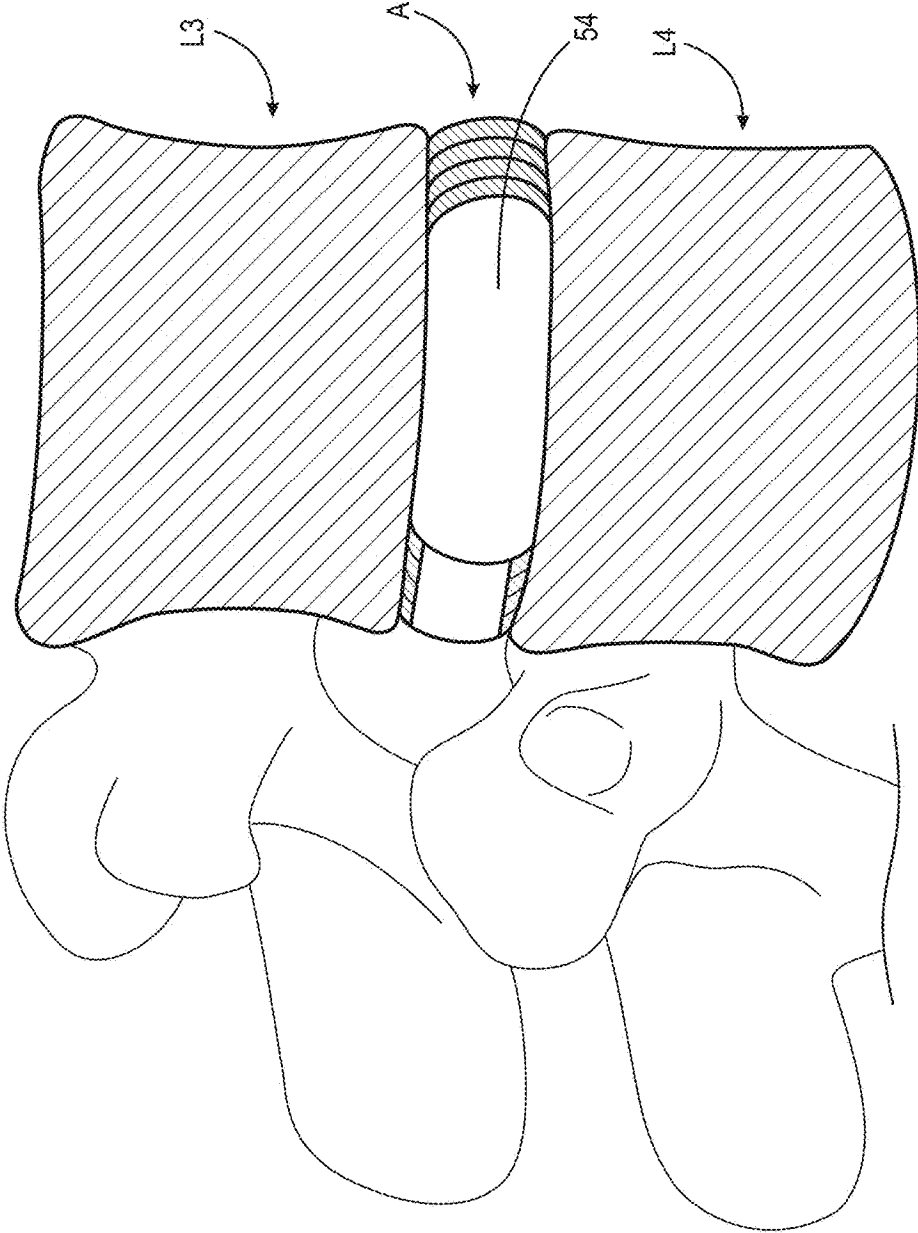

Fig. 7

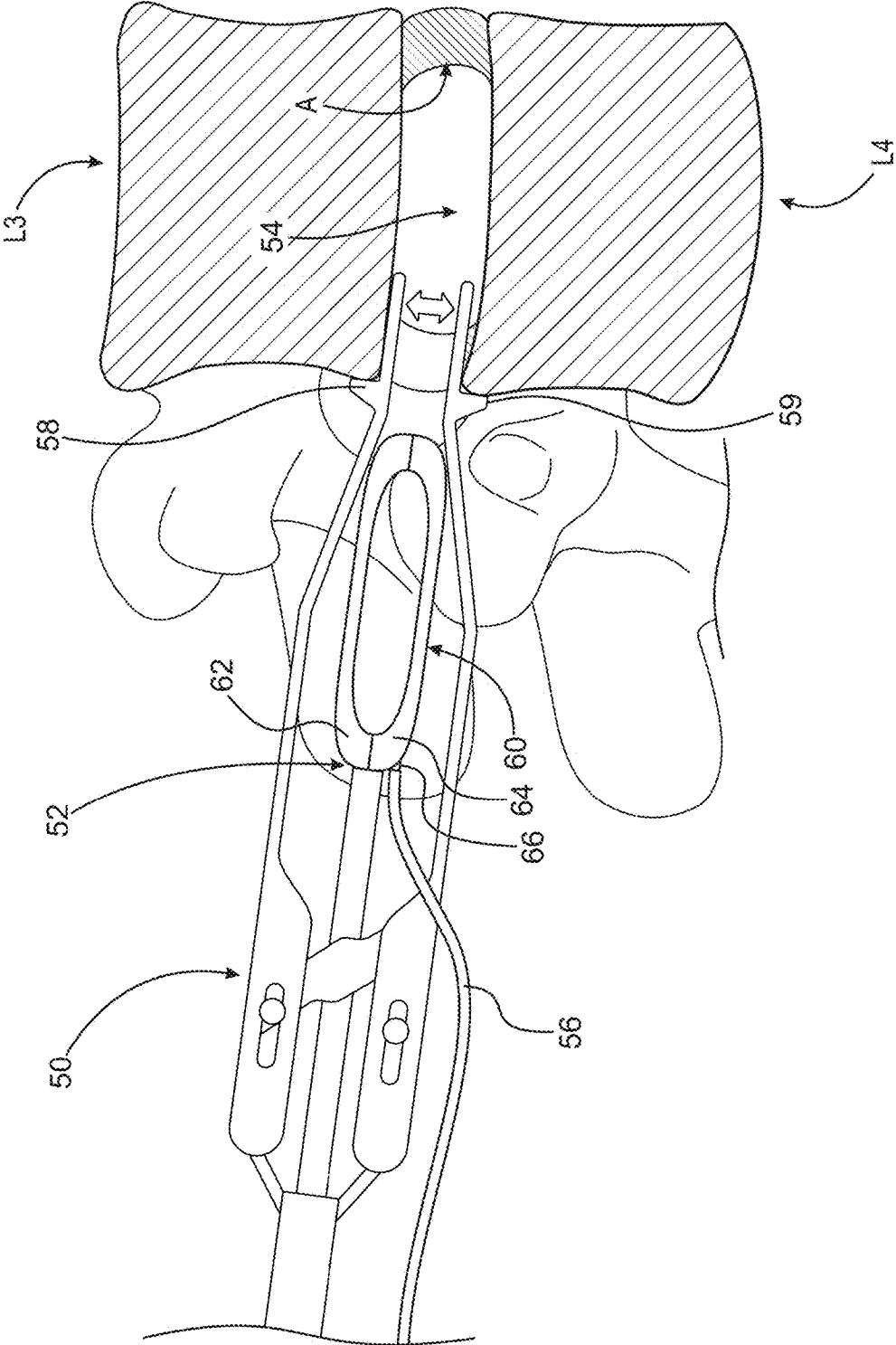

Fig. 8

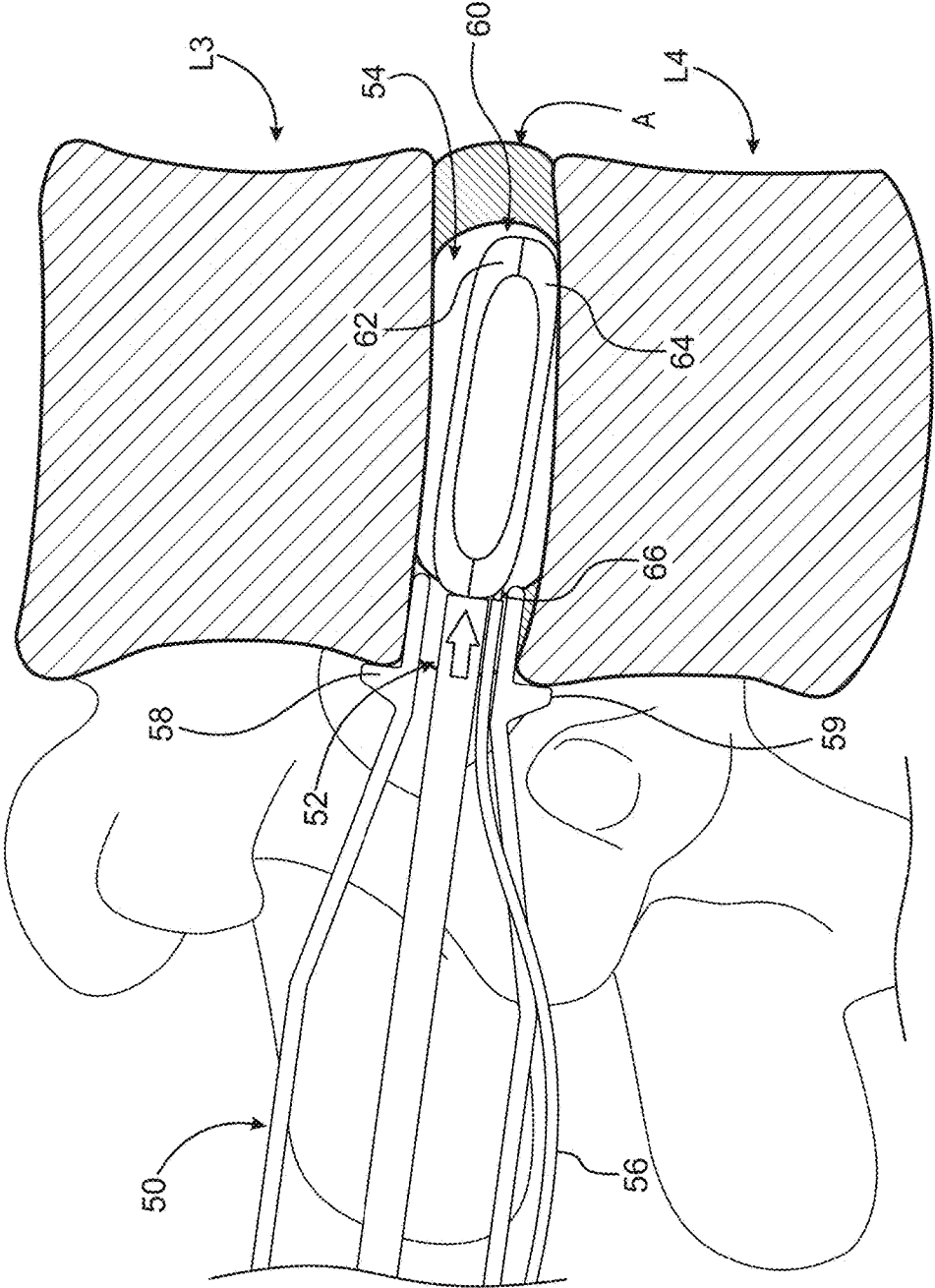

Fig. 9

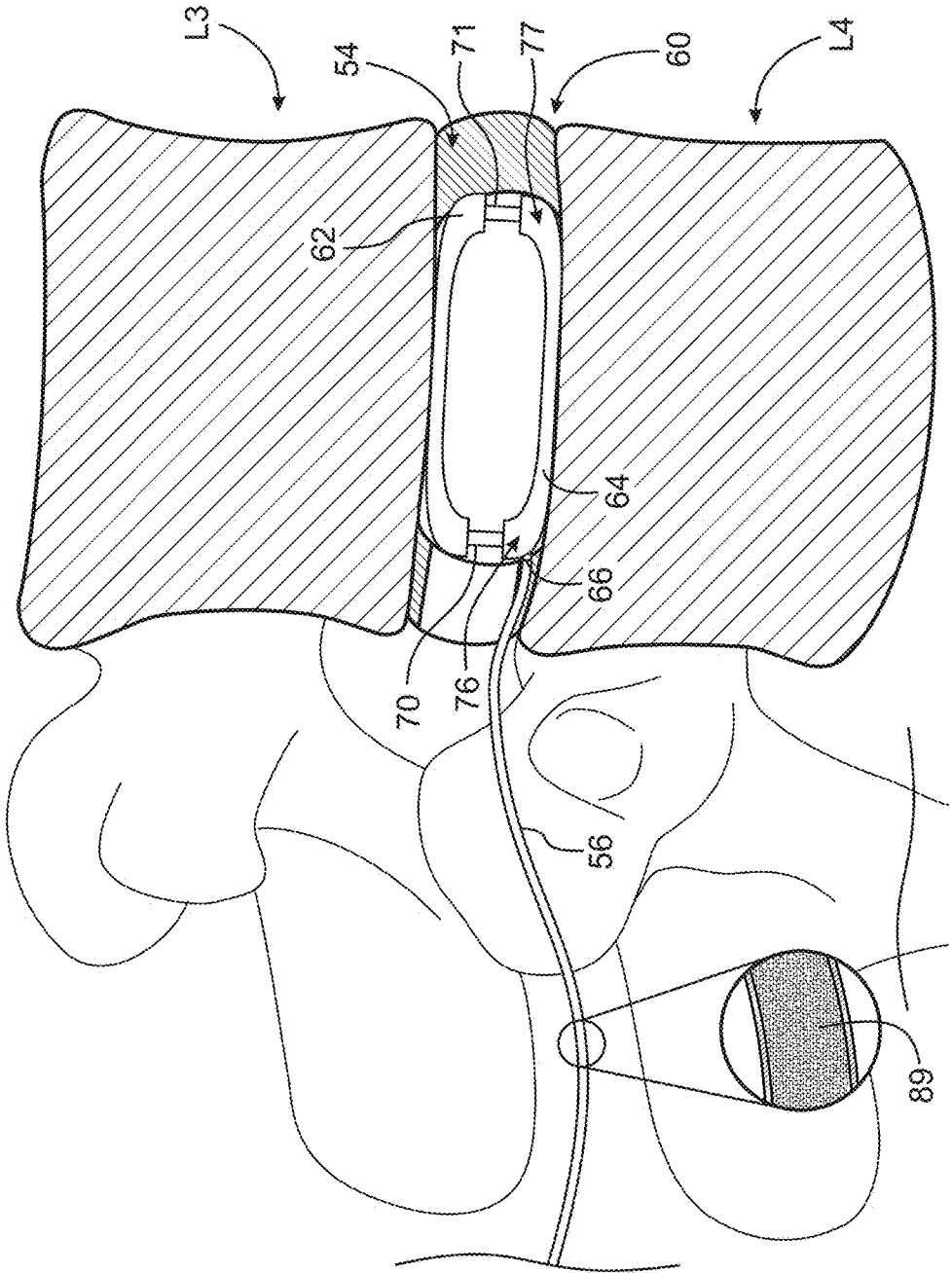

Fig. 10

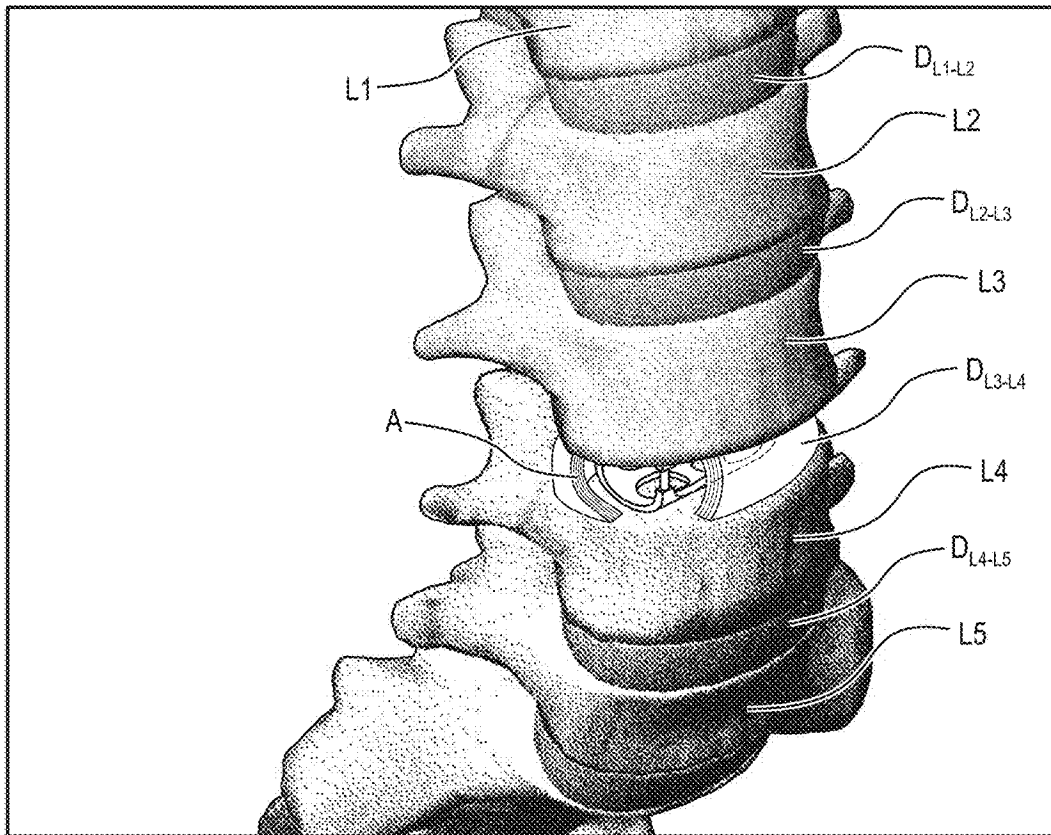

Fig. 11

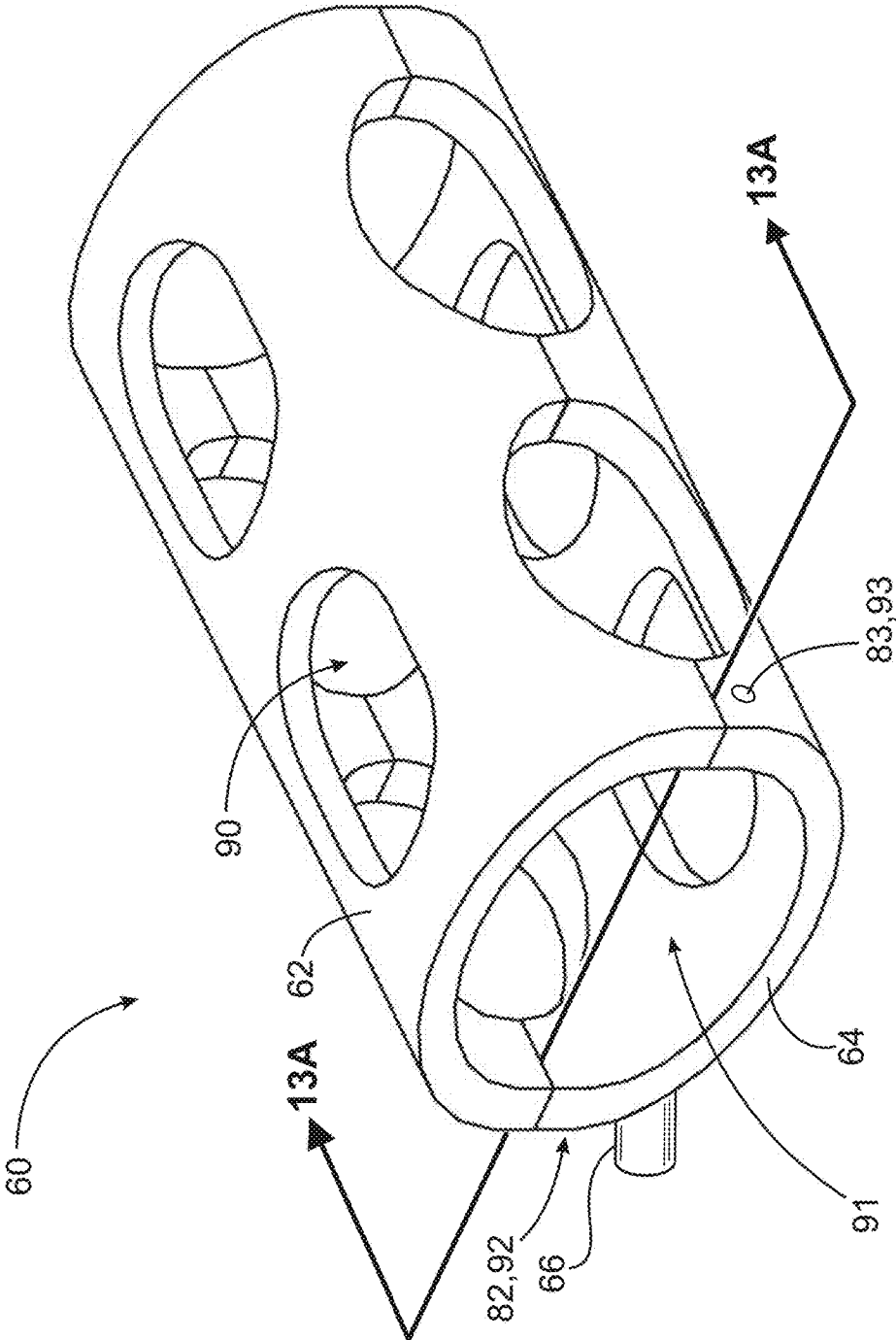

Fig. 12A

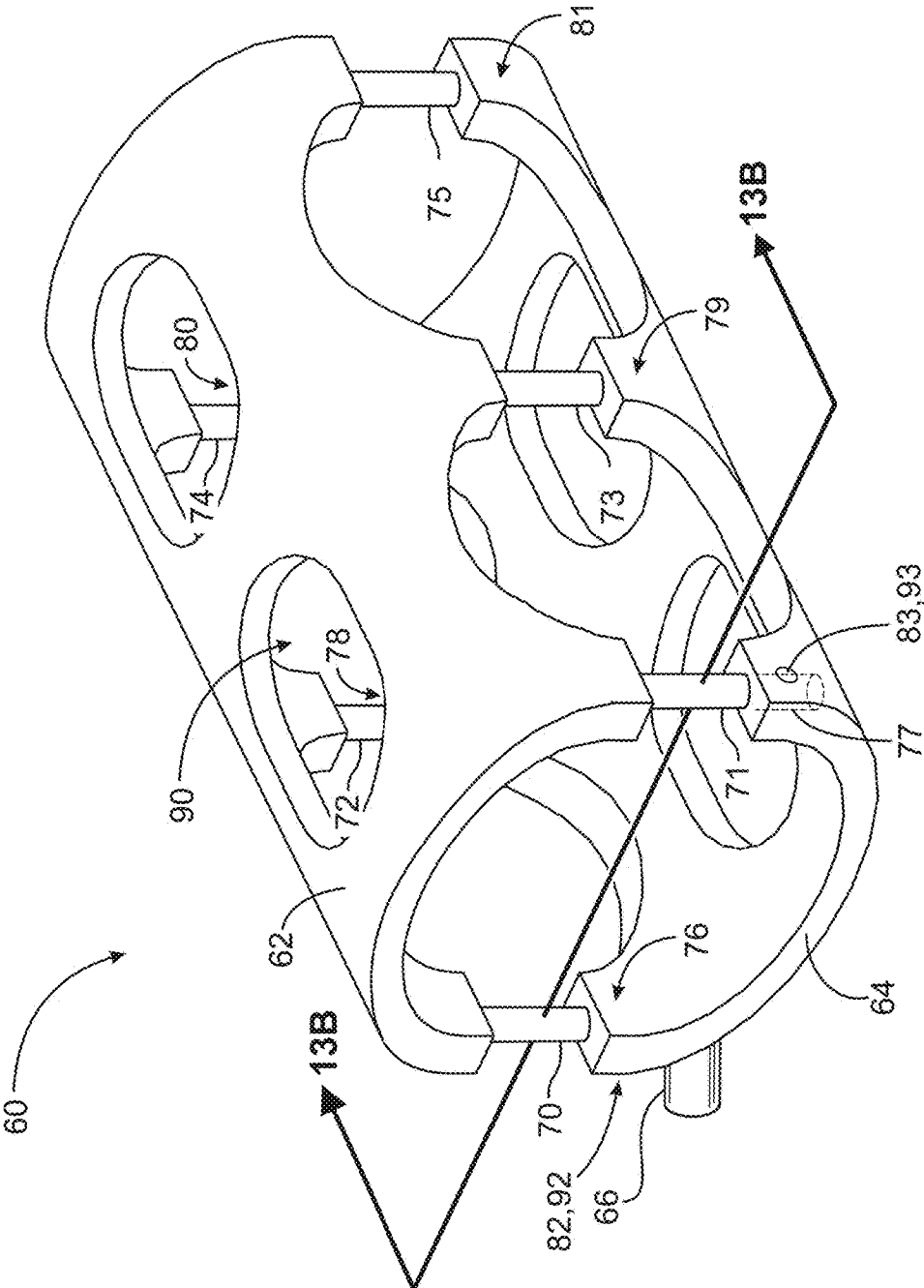

Fig. 12B





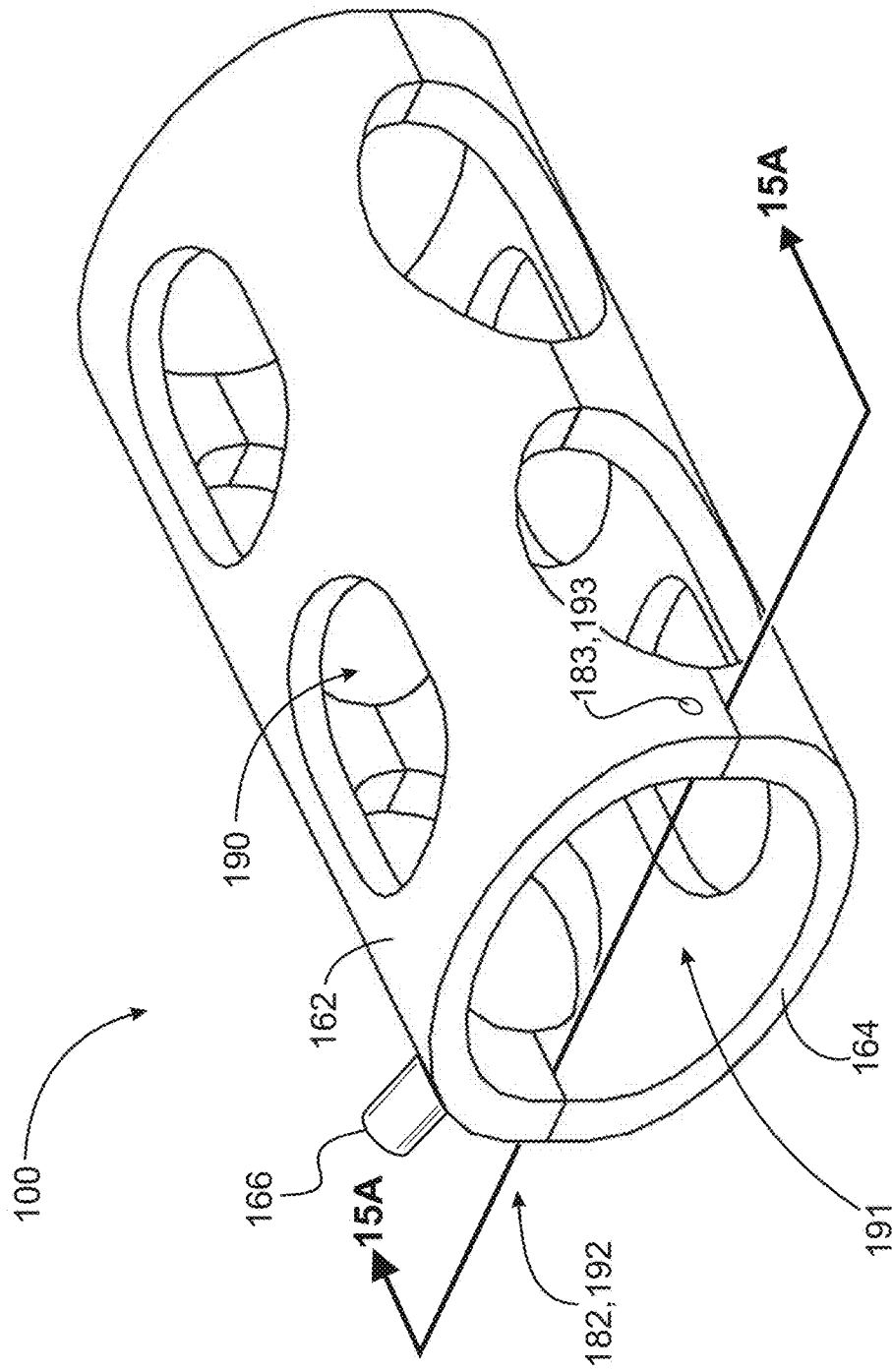

Fig. 14A

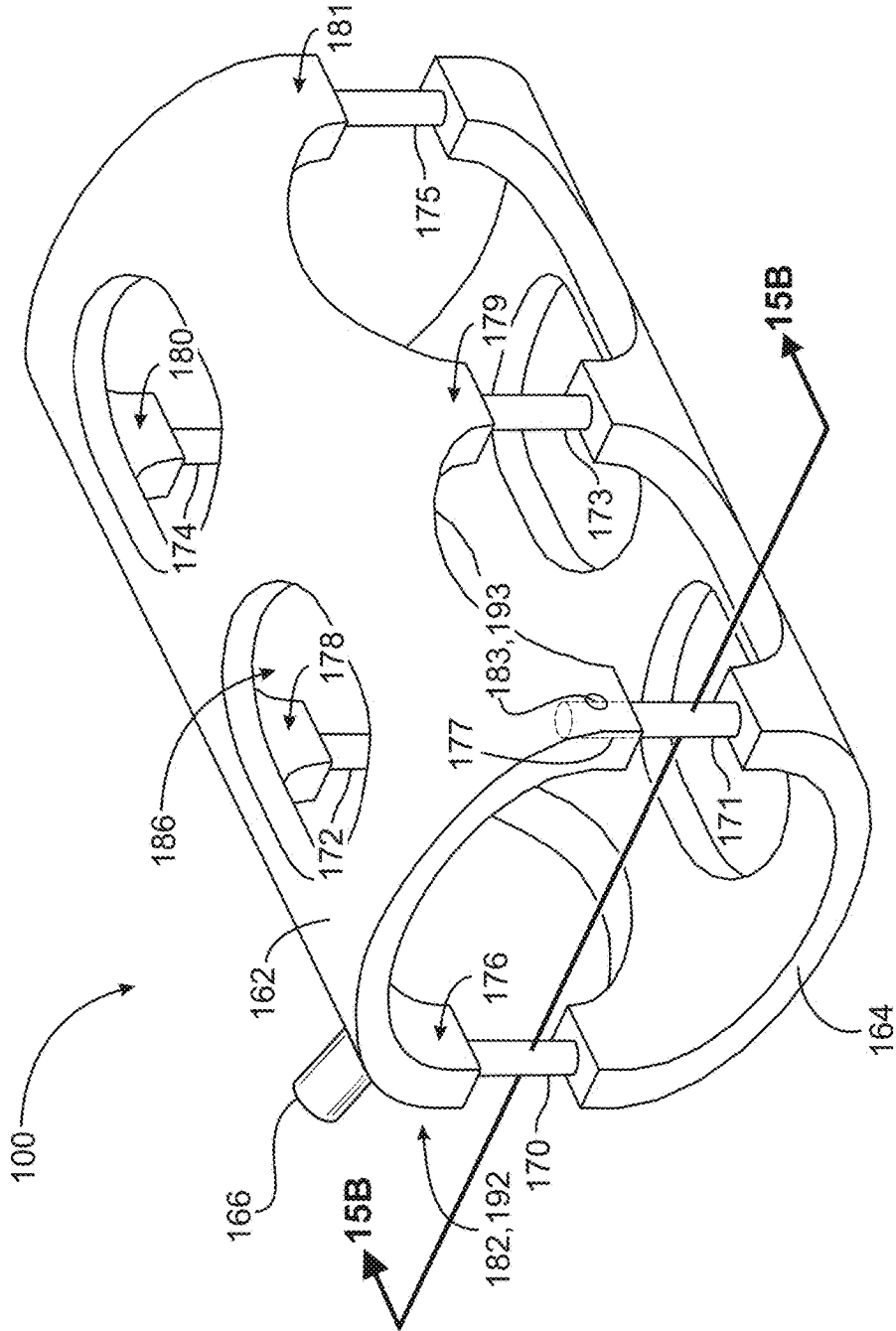

Fig. 14B

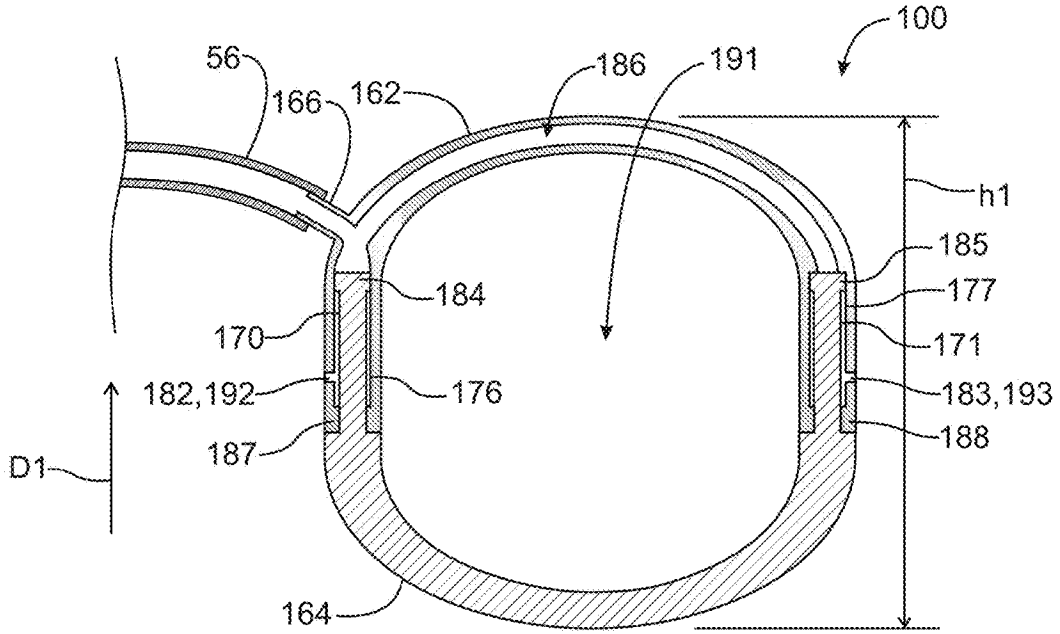

Fig. 15A

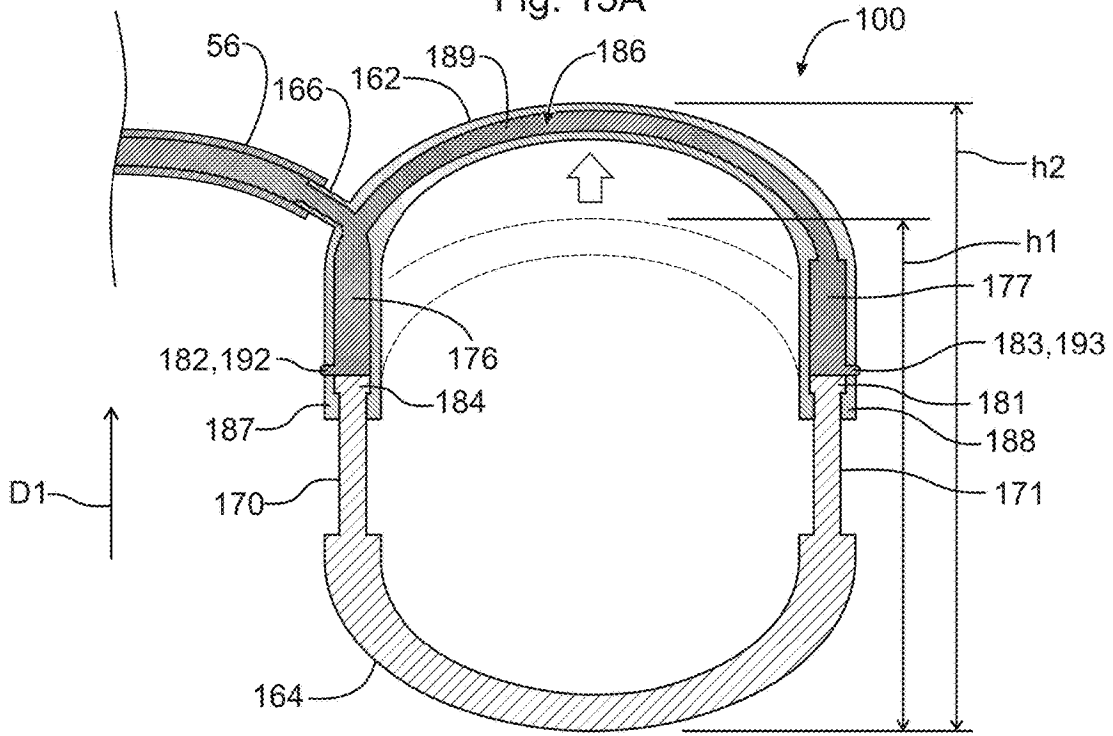

Fig. 15B



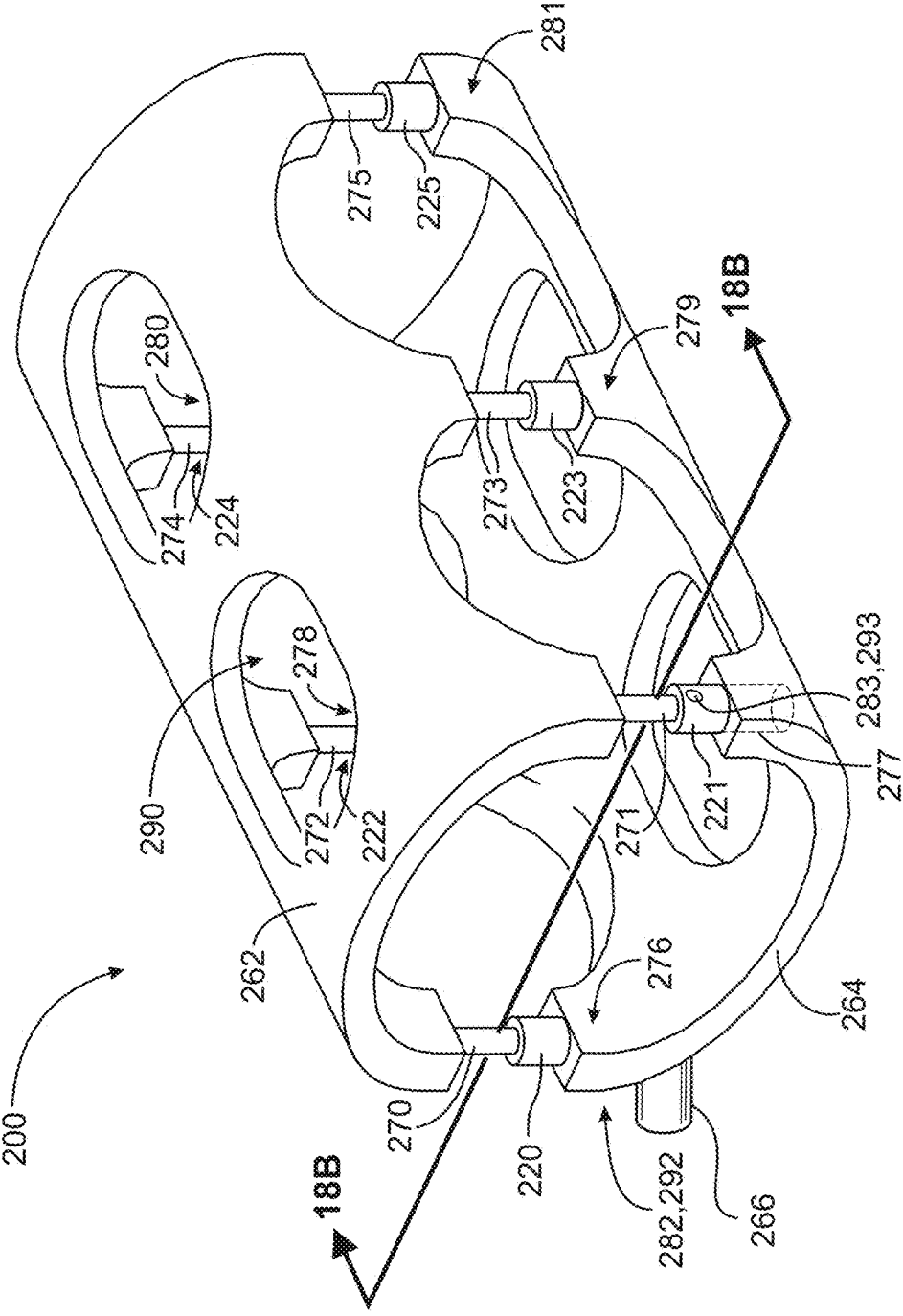
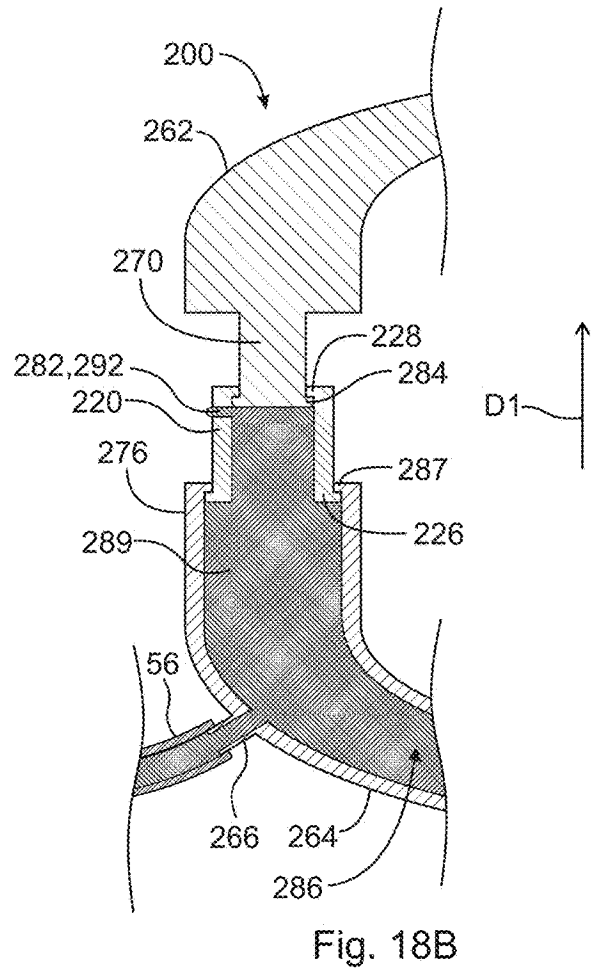
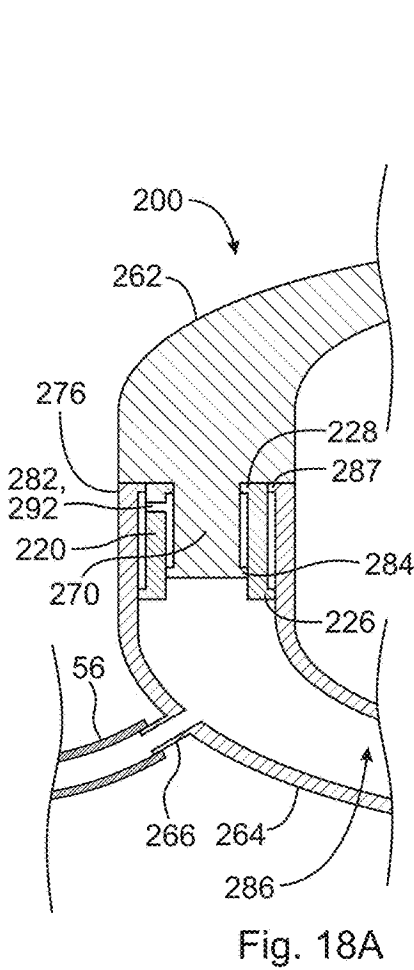
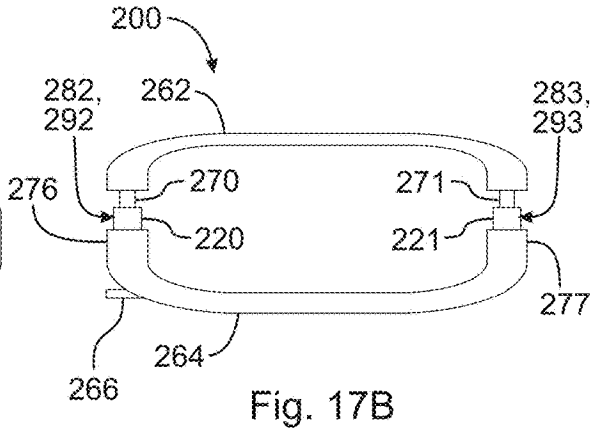
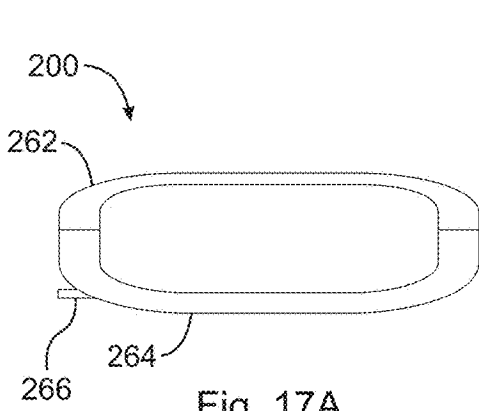

Fig. 16B



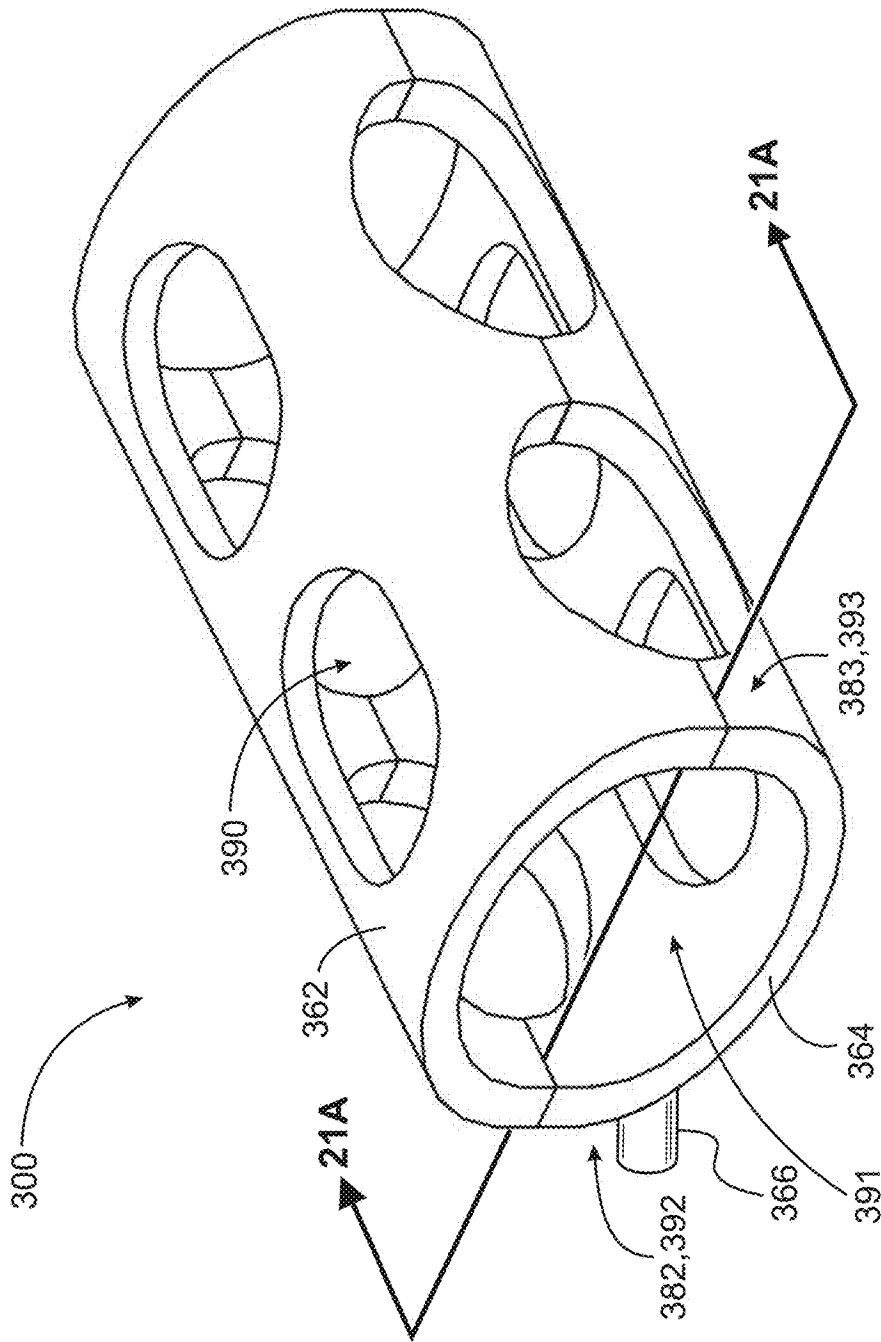

Fig. 19A



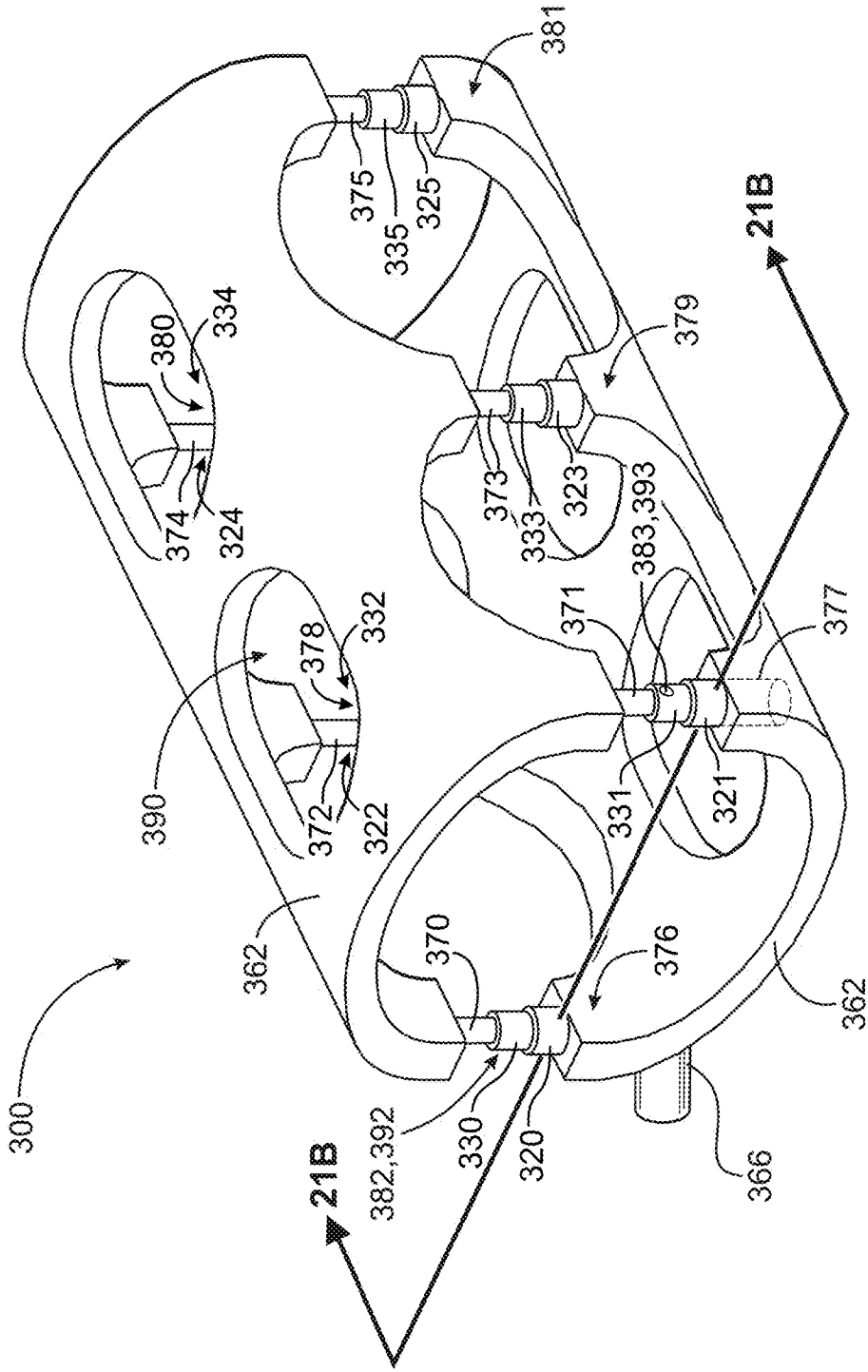

Fig. 19B

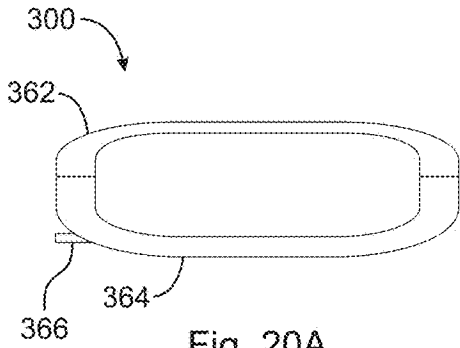

Fig. 20A

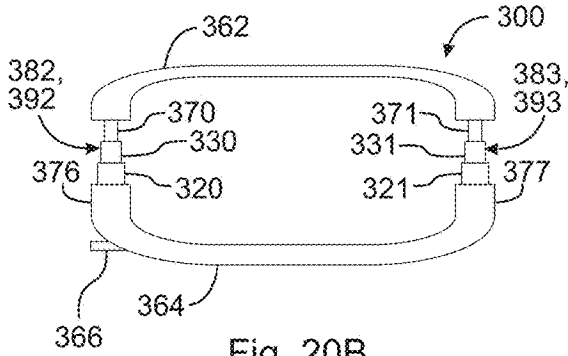

Fig. 20B

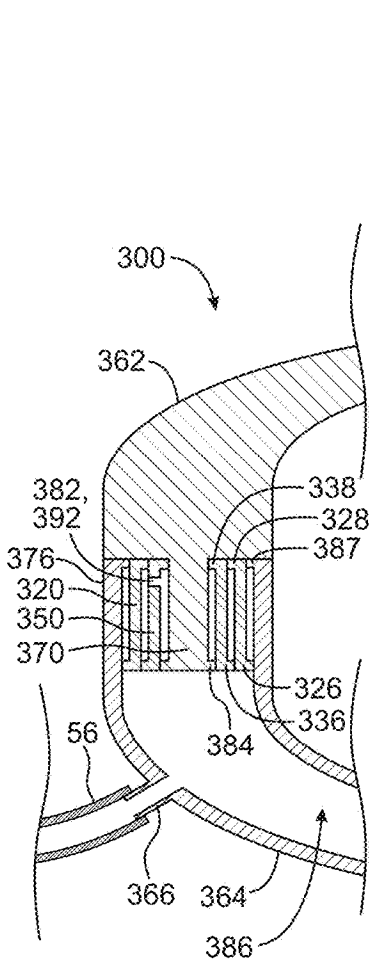

Fig. 21A

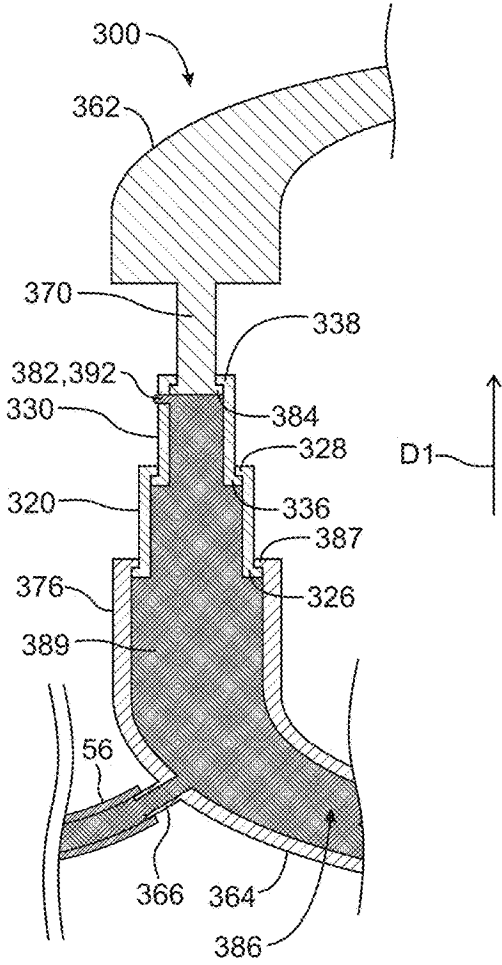
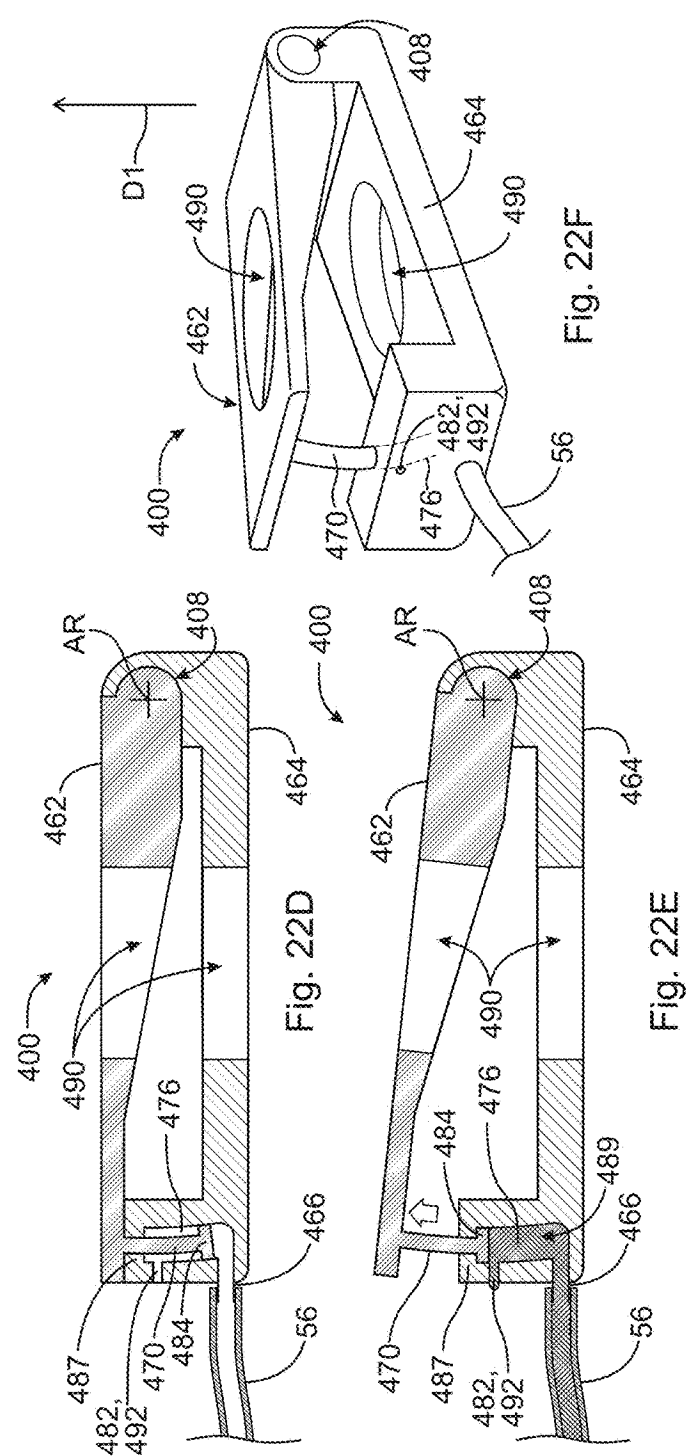
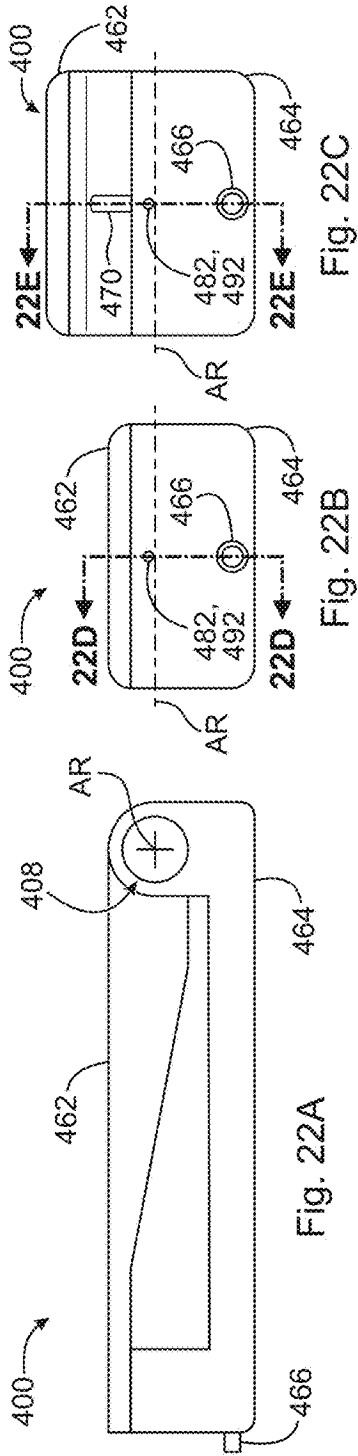

Fig. 21B



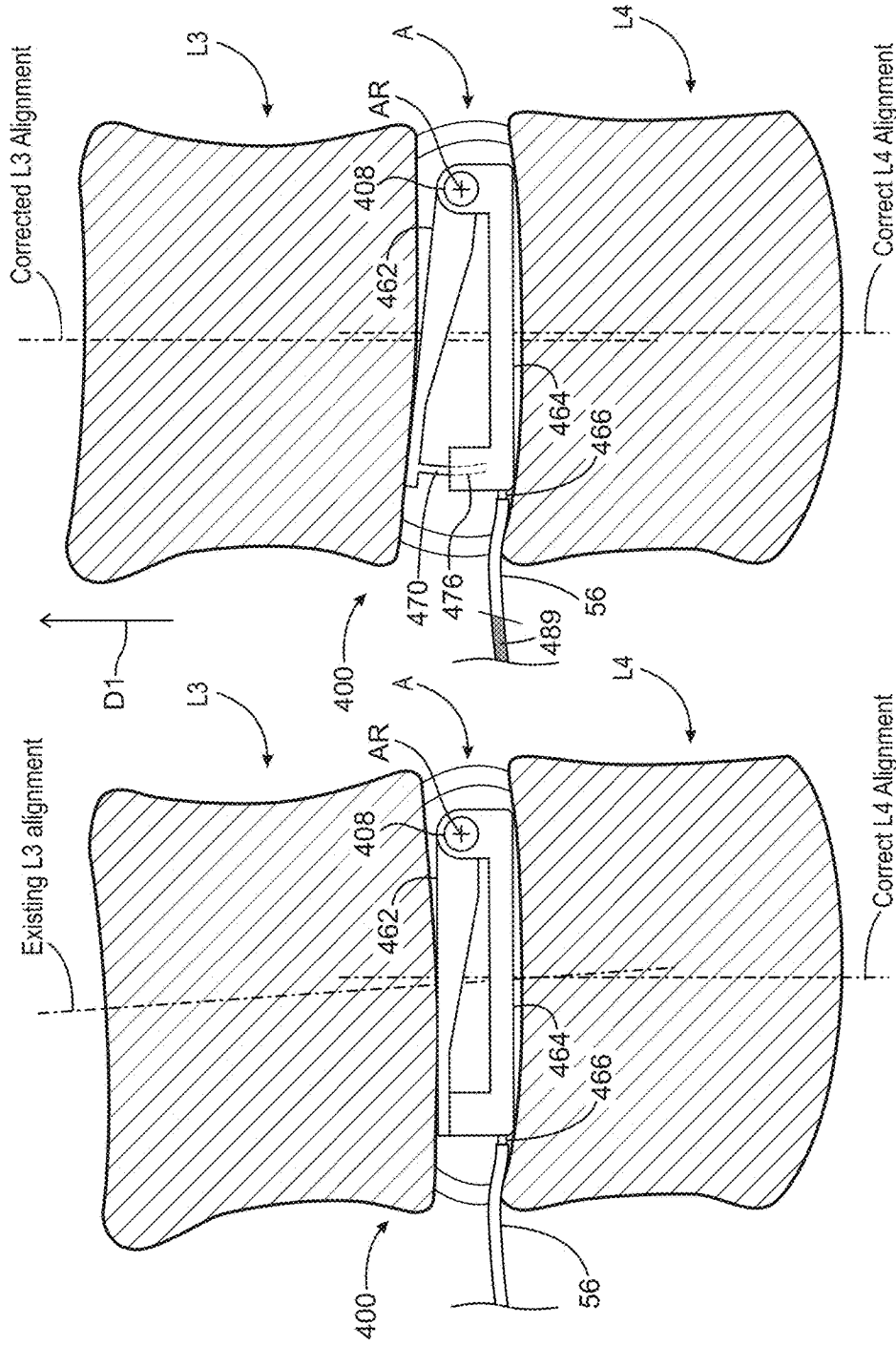

Fig. 23B

Fig. 23A

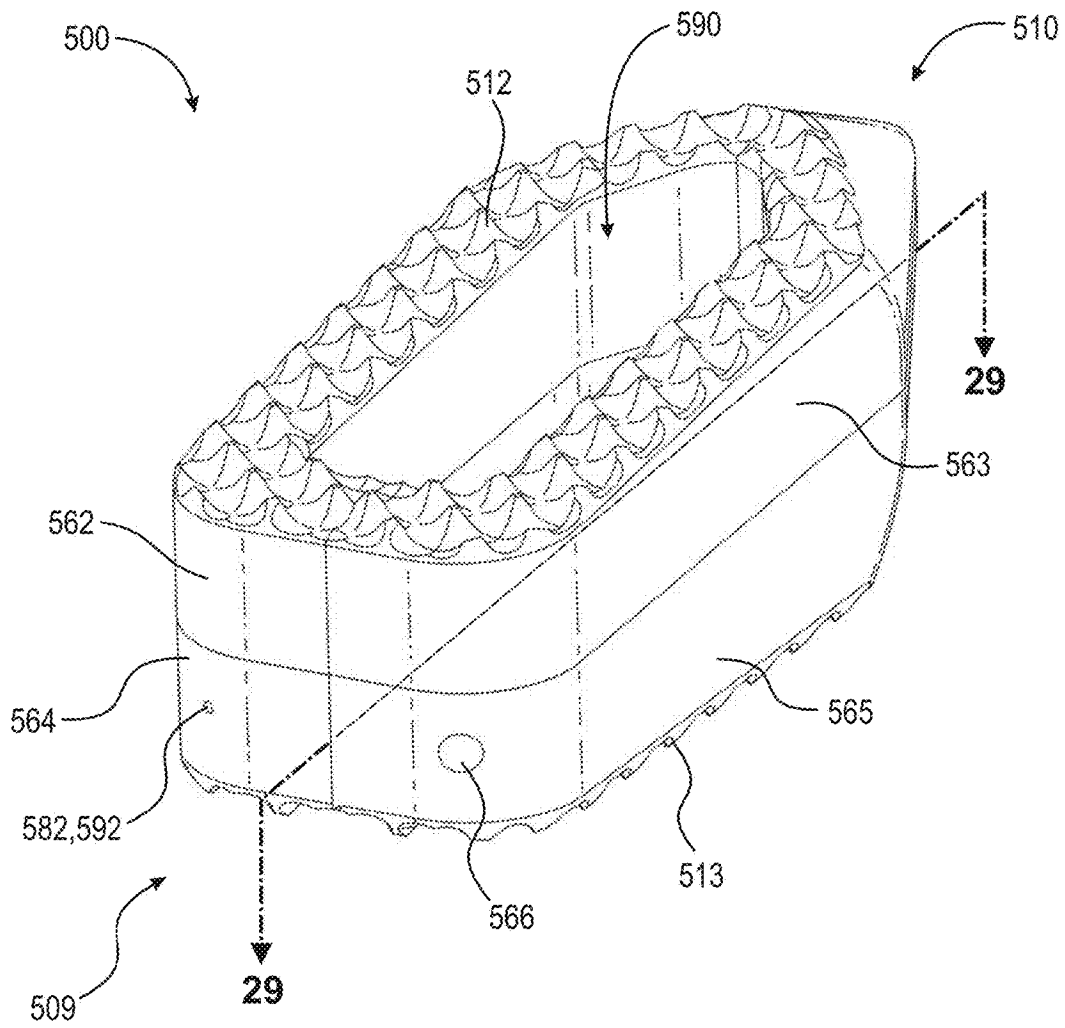

Fig. 24

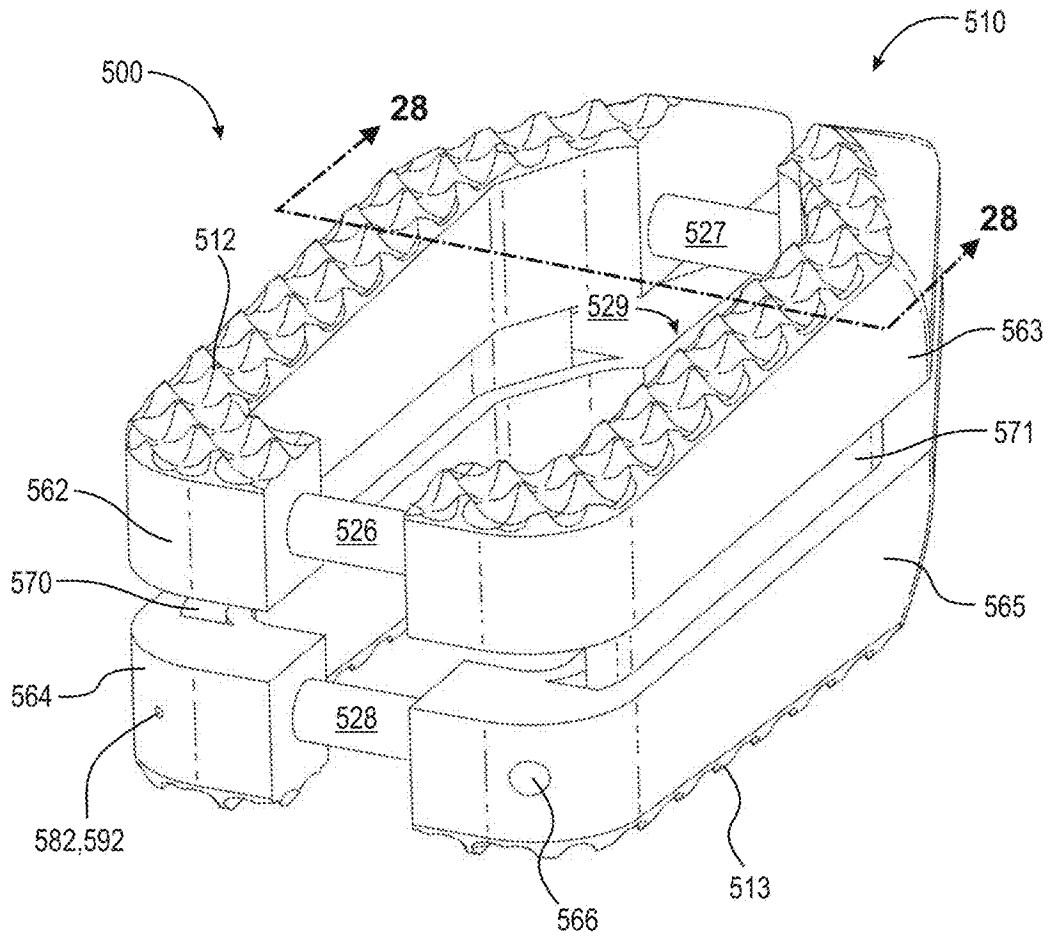
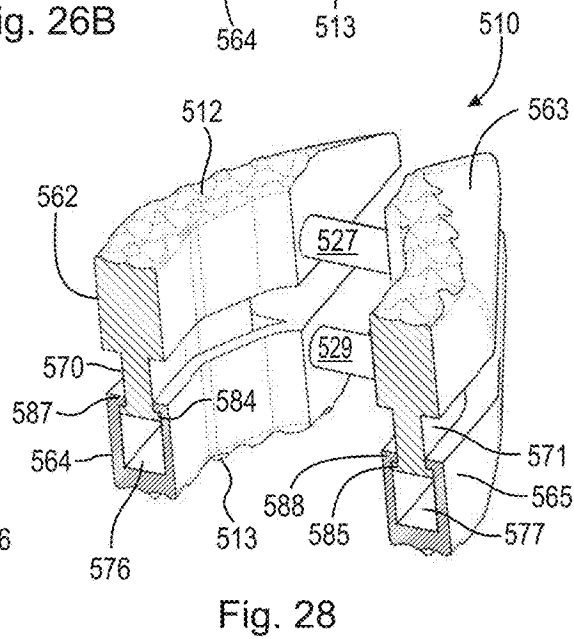
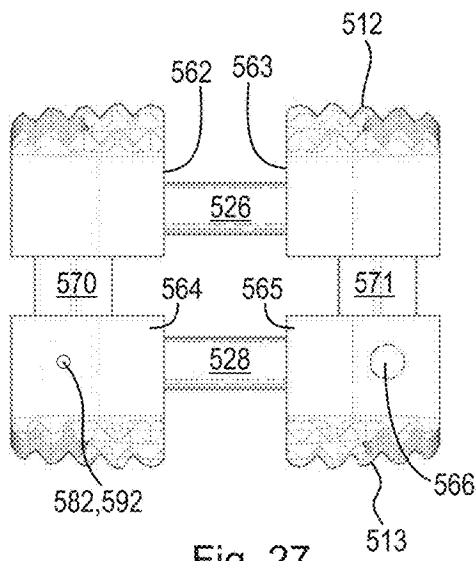
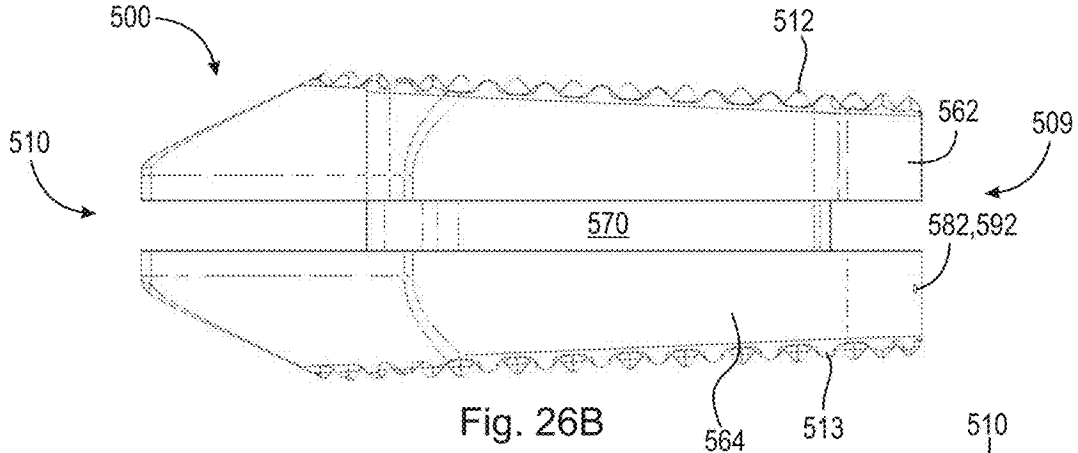
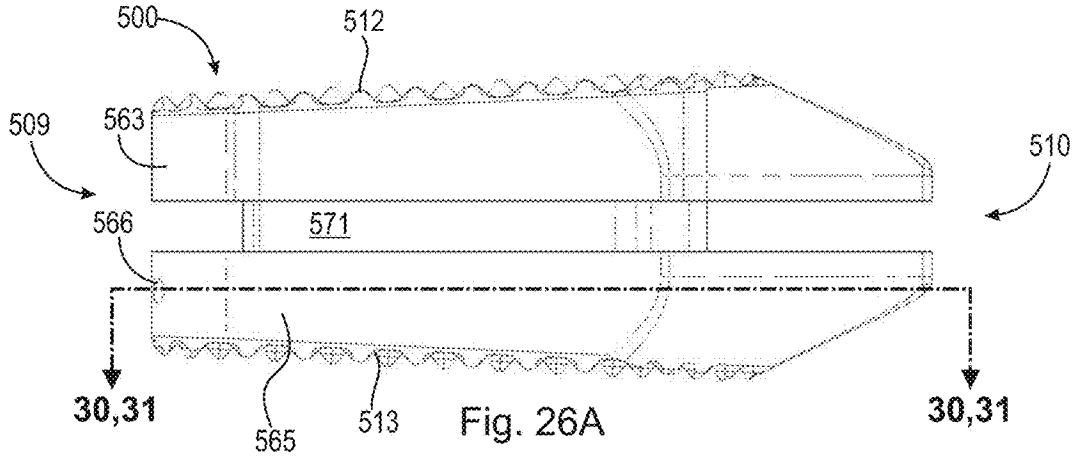

Fig. 25



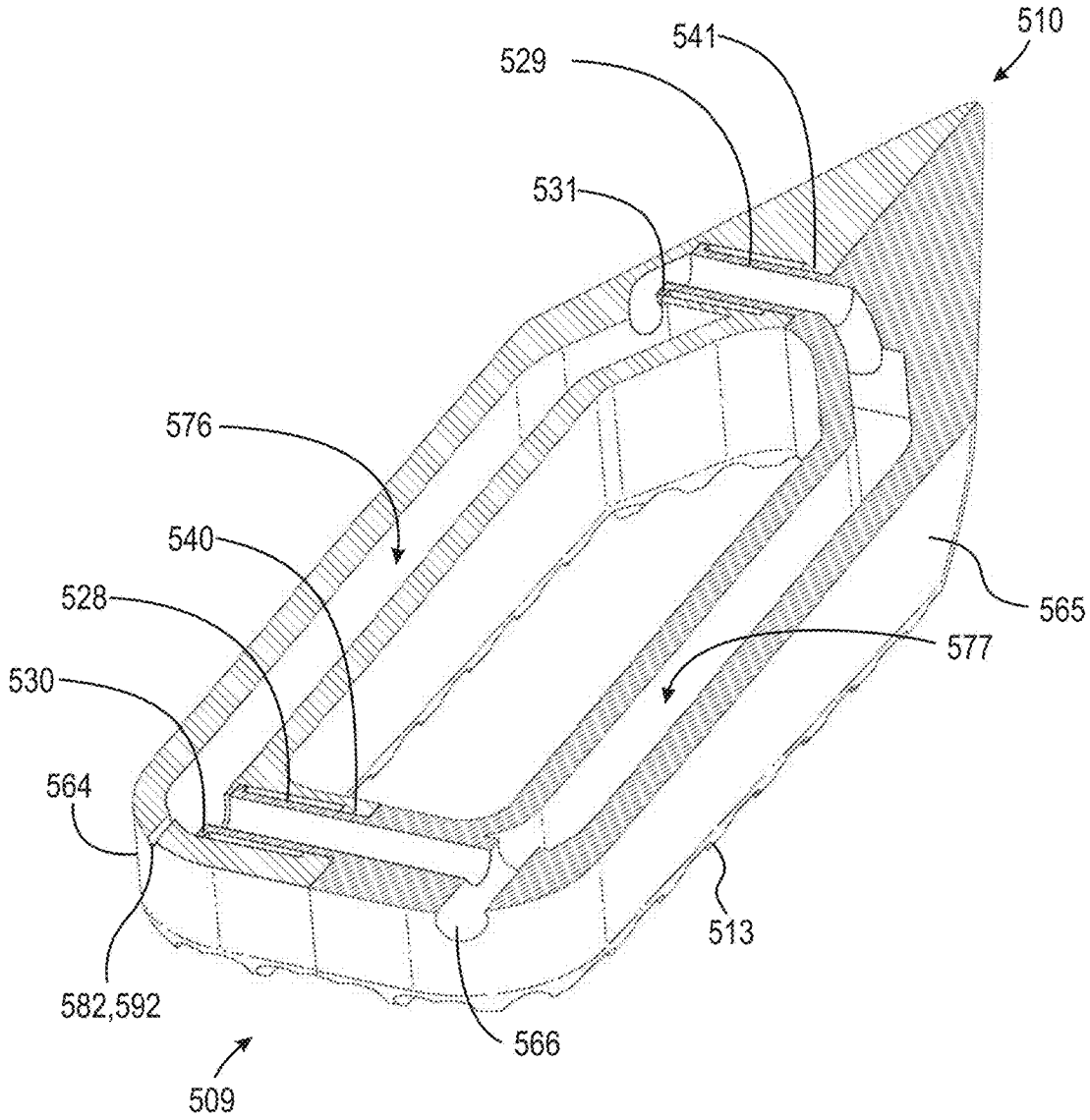

Fig. 29



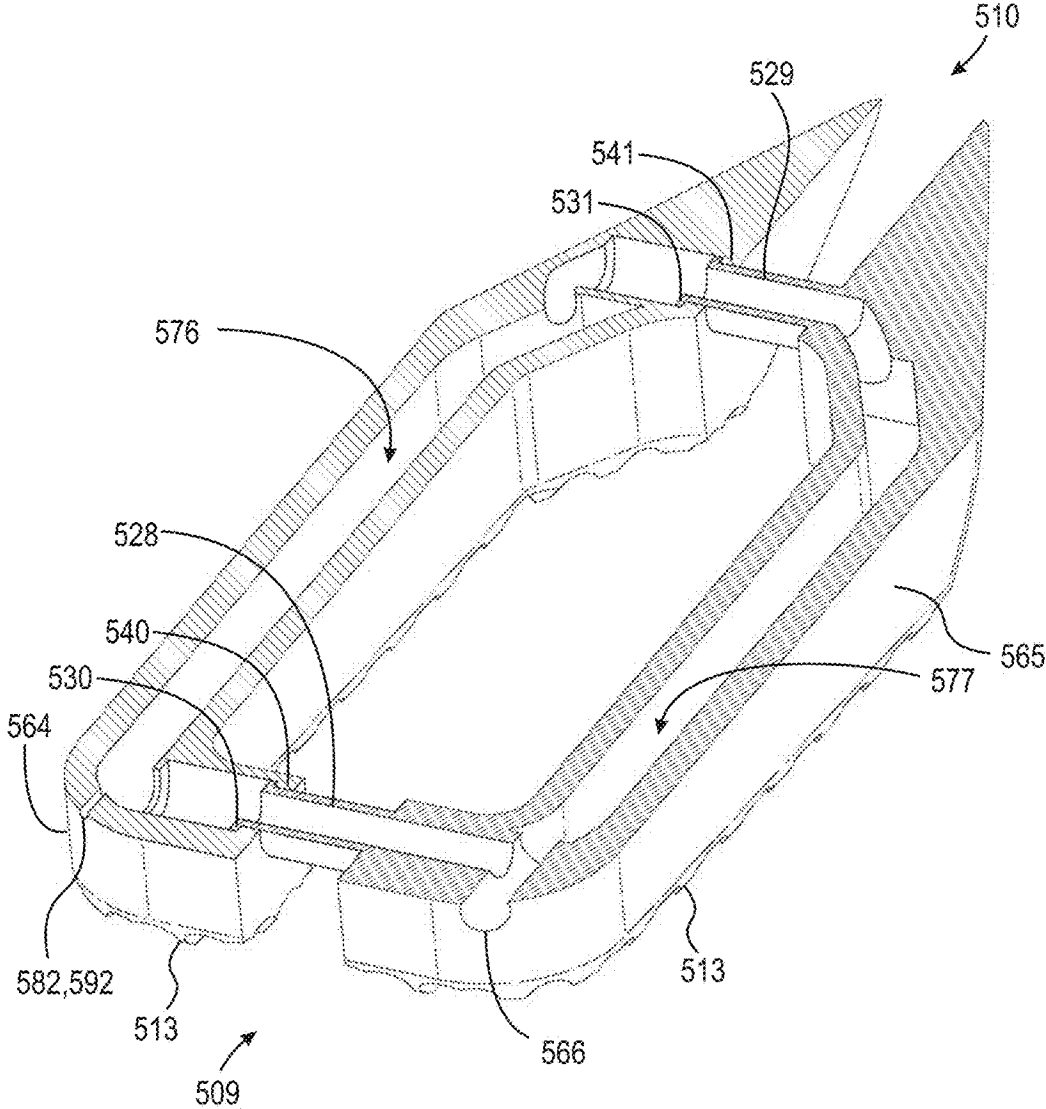

Fig. 30

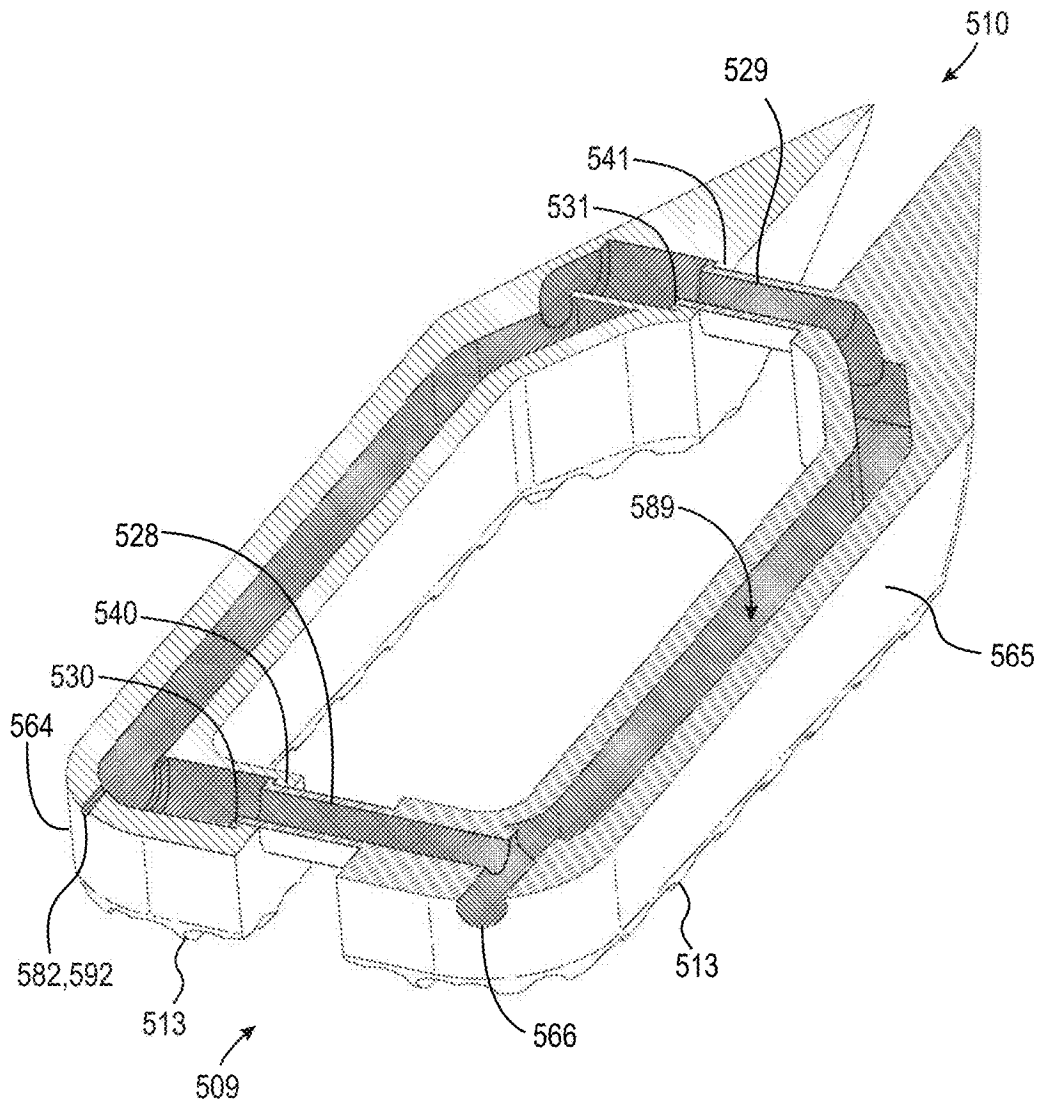

Fig. 31

1

## EXPANDABLE INTERVERTEBRAL FUSION IMPLANT

### FIELD

The invention relates to spinal surgery, more particularly to intervertebral prosthesis, and, even more specifically, to an expandable intervertebral fusion implant.

### BACKGROUND

The spinal column, or backbone, is one of the most important parts of the body. It provides the main support, allowing us to stand upright, bend, and twist. As shown in FIG. 1, thirty three (33) individual bones interlock with each other to form the spinal column. The vertebrae are numbered and divided into regions. The cervical vertebrae (C1-C7) form the neck, support the head and neck, and allow nodding and shaking of the head. The thoracic vertebrae (T1-T12) join with the ribs to form the rib cage. The five lumbar vertebrae (L1-L5) carry most of the weight of the upper body and provide a stable center of gravity when a person moves. Five vertebrae of the sacrum S and four of the coccyx C are fused. This comprises the back wall of the pelvis. Intervertebral discs are located between each of the mobile vertebra. Intervertebral discs comprise a thick outer layer with a crisscrossing fibrous structure annulus A that surrounds a soft gel-like center, the nucleus N. Discs function like shock-absorbing springs. The annulus pulls the vertebral bodies together against the elastic resistance of the gel-filled nucleus. When we bend, the nucleus acts like a ball bearing, allowing the vertebral bodies to roll over the incompressible gel. Each disc works in concert with two facet joints, forming a spinal motion segment. The biomechanical function of each pair of facet joints is to guide and limit the movement of the spinal motion segment. The surfaces of the joint are coated with cartilage that helps each joint move smoothly. Directly behind the discs, the ring-like vertebral bodies create a vertical tunnel called the spinal canal, or neuro canal. The spinal cord and spinal nerves pass through the spinal canal, which protects them from injury. The spinal cord is the major column of nerve tissue that is connected to the brain and serves as an information superhighway between the brain and the body. The nerves in the spinal cord branch off to form pairs of nerve roots that travel through the small openings between the vertebrae and the intervertebral foramina.

The repetitive forces which act on these intervertebral discs during repetitive day-to-day activities of bending, lifting and twisting cause them to break down or degenerate over time. Overt trauma, or covert trauma occurring in the course of repetitive activities disproportionately affect the more highly mobile areas of the spine. Disruption of a disc's internal architecture leads to bulging, herniation or protrusion of pieces of the disc and eventual disc space collapse. Resulting mechanical and even chemical irritation of surrounding neural elements cause pain, attended by varying degrees of disability. In addition, loss of disc space height relaxes tension on the longitudinal ligaments, thereby contributing to varying degrees of spinal instability such as spinal curvature.

Neural irritation and instability resulting from severe disc damage has been treated by removing the damaged disc and fusing adjacent vertebral elements. Removal of the disc relieves the mechanical and chemical irritation of neural elements, while osseous union solves the problem of instability. For example, in one surgical procedure, known as a

2

discectomy (or diskectomy), the surgeon removes the nucleus of the disk and replaces it with an implant. As shown in FIG. 2, it may be necessary, for example, for the surgeon to remove the nucleus of the disc between the L3 and L4 vertebrae. Disc  $D_{L3-L4}$  is shown in an enlarged view in FIG. 3. This figure also shows various anatomical structures of the spine, including facets F3A and F4A, facet joint FJ, spinous processes SP3 and SP4, transverse processes TP3A and TP4A, and intervertebral foramen IF. FIG. 4 is a top view of the section of the spinal column shown in FIG. 3, with the L3 vertebra removed to expose annulus A and nucleus N of disc  $D_{L3-L4}$ . FIG. 5 is an anterior perspective view of the section of the spinal column shown in FIG. 4. FIG. 6 is a partial cross-sectional view of the section of the spinal column shown in FIG. 5, but with vertebra L3 in place atop disc  $D_{L3-L4}$ .

While cancellous bone appears ideal to provide the biologic components necessary for osseous union to occur, it does not initially have the strength to resist the tremendous forces that may occur in the intervertebral disc space, nor does it have the capacity to adequately stabilize the spine until long term bony union occurs. For these reasons, many spinal surgeons have found that interbody fusion using bone alone has an unacceptably high rate of bone graft migration or even expulsion or nonunion due to structural failure of the bone or residual degrees of motion that retard or prohibit bony union.

Intervertebral prosthesis in various forms have therefore been used to provide immediate stability and to protect and preserve an environment that fosters growth of grafted bone such that a structurally significant bony fusion can occur.

U.S. Pat. No. 5,505,732 (Michelson) describes an apparatus and a method of inserting spinal implants in which an intervertebral space is first distracted, a hollow sleeve having teeth at one end is then driven into the vertebrae adjacent that disc space. A drill is then passed through the hollow sleeve removing disc and bone in preparation for receiving the spinal implant which is then inserted through the sleeve. Unfortunately, the apparatus does not enable a doctor to achieve great ranges of implant height, or to adjust taper angle for kyphotic or lordotic conditions.

U.S. Pat. No. 5,665,122 (Kambin) describes an expandable intervertebral cage and surgical method including a pair of cage components, each generally in the shape of a half cylinder. Each of the cage components provides a corresponding abutting conically shaped recess that cooperates with a conical end portion of an expansion screw. One of the cage components carries a fitting with an internally threaded bore that receives external threads of the expansion screw. As the expansion screw advances into the cage, the conically shaped end portion of the expansion screw engages the conically shaped recesses on the cage components to expand the two cage components apart until they are in contact with the vertebral plates of adjacent vertebrae. Like the apparatus described in the Michelson patent, the expandable intervertebral cage described in the Kambin patent does not enable a doctor to achieve great ranges of implant height. Nor does the expandable cage enable a doctor to achieve ranges of implant length or implant width.

Typical intervertebral implants have limited applicability due to the marked variation in disc space shape and height that results from biologic variation or pathologic change. For example, if a disc space is 20 mm in height, a circular implant bridging this gap requires a minimum diameter of 20 mm just to contact the end plate of the vertebral bone. Generally, endplate disruption must occur to allow a generous bony union, meaning an additional 2-3 mm must be

added to either end, resulting in a final implant size of 24-26 mm. During implantation from an anterior approach, excessive retraction of the great blood vessels is required, which greatly enhances the risk of devastating complications such as vascular tears or thrombosis. On the other hand during a posterior approach, large implant diameters may require excessive traction on neural elements for adequate placement, even if all posterior bony elements are removed. In some instances an adequate implant size cannot be inserted posteriorly, particularly if there is a significant degree of ligamentous laxity requiring higher degrees of distraction to obtain stability by tautening the annular ligamentous tension band.

Compromising on implant size risks sub-optimal stability or a loose implant which has a greater chance for migration within or expulsion from the disc space. The alternative of excessively retracting neural elements to facilitate a posterior implant application results in neuropraxia at best and permanent neural damage at worst.

Thus, there is a long-felt need for an expandable intervertebral fusion implant which can be inserted into a distracted disc space in an unexpanded state and then expanded to a desired length, and/or depth, and/or height such that minimally invasive techniques can be employed and stable long term fusion of adjacent vertebral elements is achieved.

#### SUMMARY

According to aspects illustrated herein, there is provided an expandable intervertebral fusion implant including an inferior component, a superior component telescopingly engageable with the inferior component, and a port arranged in the inferior or the superior component. When a first material is introduced through the port and into the inferior or the superior component, the inferior component is displaced in a first direction relative to the superior component.

According to aspects illustrated herein, there is provided an expandable intervertebral fusion implant having a proximal end and a distal end, the expandable intervertebral fusion implant including an inferior component, a superior component arranged to telescopingly engage the inferior component, and an input port and an output port within the proximal end and within the inferior or superior component. When the superior component is expanded to a first position relative to the inferior component, a first material is introduced into and through the hollow channel to maintain the position of the superior and inferior components.

According to aspects illustrated herein, there is provided a method of expanding an intervertebral fusion implant in a disc space between vertebral bodies including inserting the intervertebral fusion implant in an unexpanded state within the disc space, the intervertebral fusion implant having a superior component, an inferior component, a port, and a cavity formed between the superior and inferior components, and introducing a first material through the port and into the inferior component or the superior component of the intervertebral fusion implant such that a distance between the superior and inferior component increases in a first direction and the cavity increases in size.

According to aspects illustrated herein, there is provided a method of expanding an intervertebral fusion implant in a disc space between vertebral bodies including inserting the intervertebral fusion implant in an unexpanded state within the disc space, the intervertebral fusion implant having a superior component, an inferior component, a port, and a cavity formed between the superior and inferior components, expanding the intervertebral fusion implant in a first

direction such that a distance between the superior and inferior component increases in a first direction and the cavity increases in size, and introducing a first material through the port and into the inferior component or the superior component of the intervertebral fusion implant such that the distance between the superior and inferior components is maintained.

A primary object is to provide an expandable intervertebral fusion implant which can be inserted into a distracted disc space in an unexpanded state and then expanded to a desired length, and/or width, and/or height such that minimally invasive techniques can be employed and stable long term fusion of adjacent vertebral elements is achieved.

A further object is to provide an expandable intervertebral fusion implant including telescopingly engaged members which can be filled with hardenable material to cause a desired expansion.

Still another object is to provide an expandable intervertebral fusion implant including telescopingly engaged members which can be expanded initially to a desired state and thereafter filled with hardenable material to maintain the desired expanded state.

Yet another object is to provide an expandable intervertebral fusion implant which can be expanded in situ laterally, vertically and longitudinally.

Another object is to provide an expandable intervertebral fusion implant that is both simple to manufacture and simple to use in daily clinical surgical practice while remaining versatile enough to address the complex biologic and pathologic variability of the human spine.

These, and other objects and advantages, will be readily appreciable from the following description of preferred embodiments and from the accompanying drawings and claims.

#### BRIEF DESCRIPTION OF THE SEVERAL VIEWS OF THE DRAWINGS

The nature and mode of operation of the present disclosure will now be more fully described in the following detailed description of the embodiments taken with the accompanying figures, in which:

FIG. 1 is an anterior perspective view of spinal column 10;

FIG. 2 is an anterior perspective view of the lumbar section of spinal column 10;

FIG. 3 is a lateral perspective view of L3, L4 vertebrae and disc  $D_{L3-L4}$  and related spinal anatomy;

FIG. 4 is a top view of a section of the spinal column, taken generally along line 4-4 in FIG. 3;

FIG. 5 is an enlarged anterior perspective view of the spinal column shown in FIG. 2, except with vertebra L3 and all other structure above L3 removed;

FIG. 6 is a partial cross-sectional view of the L4 vertebra and  $D_{L3-L4}$  disc shown in FIG. 5, including L3 in cross-section;

FIG. 7 is a partial cross-sectional view of the L4 vertebra and  $D_{L3-L4}$  disc shown in FIG. 5, showing the removal of the disc nucleus post-discectomy;

FIG. 8 illustrates a preliminary step in an intervertebral fusion implant procedure, namely, the introduction of a distractor to the disc space;

FIG. 9 illustrates the introduction of the intervertebral fusion implant into the disc space using distractor 50 with the implant in an unexpanded state;

FIG. 10 illustrates the intervertebral fusion implant in place in the disc space, in an expanded state;

FIG. 11 is an anterior perspective view of spinal column 10 including an expanded intervertebral fusion implant;

FIG. 12A is a perspective view of an expandable intervertebral fusion implant in an unexpanded state having an input port located on the inferior component;

FIG. 12B is a perspective view of an expandable intervertebral fusion implant in an expanded state having an input port located on the inferior component;

FIG. 13A is a cross-sectional view of an expandable intervertebral fusion implant, in an unexpanded state, taken generally along line 13A-13A in FIG. 12A;

FIG. 13B is a cross-sectional view of an expandable intervertebral fusion implant, in an expanded state, taken generally along line 13B-13B in FIG. 12B;

FIG. 14A is a perspective view of an expandable intervertebral fusion implant, in an unexpanded state having an input port located on the superior component;

FIG. 14B is a perspective view of an expandable intervertebral fusion implant, in an expanded state having an input port located on the superior component;

FIG. 15A is a cross-sectional view of an expandable intervertebral fusion implant, in an unexpanded state taken generally along line 15A-15A in FIG. 14A;

FIG. 15B is a cross-sectional view of an expandable intervertebral fusion implant, in an expanded state taken generally along line 15B-15B in FIG. 14B;

FIG. 16A is a perspective view of an expandable intervertebral fusion implant, in an unexpanded state having an intermediate telescoping strut;

FIG. 16B is a perspective view of an expandable intervertebral fusion implant, in an expanded state having an intermediate telescoping strut;

FIG. 17A is a front view of an expandable intervertebral fusion implant, in an unexpanded state having an intermediate telescoping strut;

FIG. 17B is a front view of an expandable intervertebral fusion implant, in an expanded state having an intermediate telescoping strut;

FIG. 18A is a partial cross-sectional view of an expandable intervertebral fusion implant in FIG. 17A, in an unexpanded state taken generally along line 18A-18A in FIG. 16A;

FIG. 18B is a partial cross-sectional view of an expandable intervertebral fusion implant in FIG. 17B, in an expanded state taken generally along line 18B-18B in FIG. 16B;

FIG. 19A is a perspective view of an expandable intervertebral fusion implant, in an unexpanded state having a first intermediate telescoping strut and a second intermediate telescoping strut;

FIG. 19B is a perspective view of an expandable intervertebral fusion implant, in an expanded state having a first intermediate telescoping strut and a second intermediate telescoping strut;

FIG. 20A is a front view of an expandable intervertebral fusion implant, in an unexpanded state having a first intermediate telescoping strut and a second intermediate telescoping strut;

FIG. 20B is a front view of an expandable intervertebral fusion implant, in an expanded state having a first intermediate telescoping strut and a second intermediate telescoping strut;

FIG. 21A is a partial cross-sectional view of an expandable intervertebral fusion implant in FIG. 20A, in an unexpanded state taken generally along line 21A-21A in FIG. 19A;

FIG. 21B is a partial cross-sectional view of an expandable intervertebral fusion implant in FIG. 20B, in an expanded state taken generally along line 21B-21B in FIG. 19B;

FIG. 22A is a side view of a hingedly expandable intervertebral fusion implant, in an unexpanded state;

FIG. 22B is a front view of a hingedly expandable intervertebral fusion implant, in an unexpanded state;

FIG. 22C is a front view of a hingedly expandable intervertebral fusion implant, in an expanded state;

FIG. 22D is a cross-sectional view of a hingedly expandable intervertebral fusion implant in FIG. 22A, in an unexpanded state taken along line 22D-22D in FIG. 22B;

FIG. 22E is a cross-sectional view of a hingedly expandable intervertebral fusion implant in FIG. 22A, in an expanded state taken along line 22E-22E in FIG. 22C;

FIG. 22F is a perspective view of a hingedly expandable intervertebral fusion implant, in an expanded state;

FIG. 23A illustrates a hingedly expandable intervertebral fusion implant in place in the disc space, in an unexpanded state;

FIG. 23B illustrates a hingedly expandable intervertebral fusion implant in place in the disc space, in an expanded state;

FIG. 24 is a perspective view of a bilaterally expandable intervertebral fusion implant, in an unexpanded state;

FIG. 25 is a perspective view of a bilaterally expandable intervertebral fusion implant, in an expanded state;

FIG. 26A is a side view of a bilaterally expandable intervertebral fusion implant, in an expanded state;

FIG. 26B is an opposite side view of a bilaterally expandable intervertebral fusion implant, in an expanded state;

FIG. 27 is a front view of a bilaterally expandable intervertebral fusion implant, in an expanded state;

FIG. 28 is a cross-sectional view of a bilaterally expandable intervertebral fusion implant, in an expanded state taken generally along line 28-28 in FIG. 25;

FIG. 29 is a cross-sectional view of a the inferior component of a bilaterally expandable intervertebral fusion implant, in an unexpanded state taken generally along line 29-29 in FIG. 24;

FIG. 30 is a cross-sectional view of a the inferior component of a bilaterally expandable intervertebral fusion implant, in an expanded state taken generally along line 30-30 in FIG. 26A; and,

FIG. 31 is a cross-sectional view of a the inferior component of a bilaterally expandable intervertebral fusion implant, in an expanded state showing hardenable material taken along line 31-31 in FIG. 26A;

#### DETAILED DESCRIPTION OF EMBODIMENTS

At the outset, it should be appreciated that like drawing numbers on different drawing views identify identical, or functionally similar, structural elements. While the embodiments are described with respect to what is presently considered to be the preferred aspects, it is to be understood that the invention as claimed is not limited to the disclosed aspect. The present invention is intended to include various modifications and equivalent arrangements within the spirit and scope of the appended claims.

Furthermore, it is understood that this disclosure is not limited to the particular methodology, materials and modifications described and, as such, may, of course, vary. It is also understood that the terminology used herein is for the purpose of describing particular aspects only, and is not

intended to limit the scope of the present invention, which is limited only by the appended claims.

Unless defined otherwise, all technical and scientific terms used herein have the same meaning as commonly understood to one of ordinary skill in the art to which this invention belongs. Although any methods, devices or materials similar or equivalent to those described herein can be used in the practice or testing of the invention, the preferred methods, devices, and materials are now described.

Adverting now to the Figures, FIG. 8 is a partial cross-sectional view of the L3 and L4 vertebra with disc  $D_{L3-L4}$  removed (post discectomy).

FIGS. 8 and 9 illustrate introduction of disc space distractor 50. Distractor 50 is used to maintain distance between vertebrae L3 and L4 and insert expandable intervertebral fusion implant 60 into disc space 54 between the above-mentioned vertebrae. Disc space distractor 50 includes spacers 58 and 59. Spacer 58 is placed between L3 and L4 and contacts the plate of vertebra L3. Spacer 59 is placed between L3 and L4 and contacts the plate of vertebra L4. Spacers 58 and 59 are then separated to enlarge disc space 54. Once disc space 54 is large enough, expandable intervertebral fusion implant 60 may be introduced in an unexpanded state. It should be understood that any suitable tool can be used to maintain distance between the vertebrae and insert the implant.

FIG. 10 illustrates expandable intervertebral fusion implant 60 in disc space 54, in an expanded state.

FIG. 11 is an anterior perspective view of spinal column 10 including expandable intervertebral fusion implant 60.

FIG. 12A is a perspective view of expandable intervertebral fusion implant 60 in an unexpanded state. In the unexpanded state, expandable intervertebral fusion implant 60 comprises superior component 62, inferior component 64, and input port 66. Superior and inferior components 62 and 64 are telescopingly engageable. Superior component 62 comprises a body with a generally arcuate shape (quasi-elliptical cross-section), although implants of other shapes are certainly possible and intended to be within the scope of the appended claims. The body is shown as having at least one aperture 90. Inferior component 64 also comprises a body with an arcuate shape, having at least one aperture 90, and input port 66. The inferior and superior components are of similar shapes and dimensions so as to be capable of matingly engaging one another. When expandable intervertebral fusion implant 60 is in the unexpanded state, superior component 62 and inferior component 64 form a hollow, substantially tubular structure having a cavity 91.

FIG. 12B is a perspective view of expandable intervertebral fusion implant 60 in an expanded state. Superior component 62 further comprises a plurality of downwardly extending struts 70, 71, 72, 73, 74 and 75. Inferior component 64 further comprises a plurality of upwardly extending hollow channels 76, 77, 78, 79, 80 and 81 that receive, and telescopingly engage with, downwardly extending struts 70, 71, 72, 73, 74 and 75 respectively. The plurality of upwardly extending hollow channels 76, 77, 78, 79, 80 and 81 are also connected to input port 66. Each hollow channel also includes a vent as described infra.

FIG. 13A is a cross-sectional view of an expandable intervertebral fusion implant, in an unexpanded state, taken generally along line 13A-13A in FIG. 12A. Inferior component 64 further comprises channel 86 that connects the plurality of upwardly extending hollow channels 76, 77, 78, 79, 80 and 81. Each of upwardly extending hollow channels 76, 77, 78, 79, 80, and 81 further comprise a retention shoulder operatively arranged to limit movement of the

corresponding struts, and prevent the struts from exiting the channels. For example, channel 76 includes shoulder 87 to limit movement of strut 70. Strut 70 includes flange 84 which abuts shoulder 87 when the implant is completely expanded. Similarly, channel 77 includes shoulder 88 to limit movement of strut 71. Strut 71 includes flange 85 which abuts shoulder 88 when the implant is completely expanded.

FIG. 13B is a cross-sectional view of an expandable intervertebral fusion implant, in an expanded state, taken generally along line 13B-13B in FIG. 12B. Hardenable material 89 is injected via input port 66, filling the plurality of upwardly extending hollow channels 76, 77, 78, 79, 80 and 81, as well as channel 86. Injecting hardenable material 89 creates hydraulic pressure within the hollow channels and forces the plurality of downwardly extending struts 70, 71, 72, 73, 74 and 75 in a first direction D1, displacing superior component 62 in a first direction D1.

Each of downwardly extending struts 70, 71, 72, 73, 74 and 75 further comprise a flange operatively arranged to limit movement of each strut within its respective channel. For example, as shown in FIG. 13B, flange 84 of strut 70 is shown abutting shoulder 87, and flange 85 of strut 71 is shown abutting shoulder 88 when the implant is in a fully expanded state. In an unexpanded state, expandable intervertebral fusion implant 60 has a collapsed height  $h_1$ . As hardenable material 89 is introduced via port 66, and evenly distributed to upwardly extending hollow channels 76, 77, 78, 79, 80 and 81 through channel 86, downwardly extending struts 70, 71, 72, 73, 74 and 75 causing the displacement of superior component 62, in a first direction D1. Upwardly extending hollow channels 76, 77, 78, 79, 80 and 81, as well as channel 86 continue to fill with hardenable material 89, until each flange abuts its respective shoulder, whereby the displacement of superior component 62 is stopped, resulting in expandable intervertebral fusion implant 60 having an expanded height  $h_2$ . The flanges and shoulder are thus arranged to prevent the struts from being expelled from the channels.

As hardenable material 89 is injected into upwardly extending hollow channels 76, 77, 78, 79, 80 and 81, the air originally contained within the hollow channels as well as channel 86, escapes via vents. For example, channels 76 and 77 each have a vent 82 and 83, respectively. When expandable intervertebral fusion implant 60 is in an expanded state, having expanded height  $h_2$ , flange 84 is in contact with retention shoulder 87, allowing hardenable material 89 to escape via vent 82. When hardenable material 89 escapes vent 82 instead of air, this signals that the upwardly extending hollow channels have completely filled with hardenable material. (The surgeon can actually see the hardenable material escaping through the vents with an endoscope.) When the surgeon sees the hardenable material escape through the vents, the surgeon is then free to cut injection tube 56 at input port 66, remove the injection tube, and let the hardenable material cure and harden, locking the implant in its expanded state. It should be understood that the vents within each respective hollow channel further contain a valve. For example, vent 82 further comprises valve 83 to allow control of the rate of escaping air and hydraulic pressure within the hollow channels. In the preferred embodiment, hardenable material 89 would be made of poly(methyl methacrylate), polycarbonate resins, epoxy resins, polyamide resins, or equivalent. In the preferred embodiment, superior component 62 and inferior component 64 of expandable intervertebral fusion implant 60 are made of Polyether ether ketone and titanium, or equivalent.

FIG. 14A is a perspective view of an expandable intervertebral fusion implant **100**, comprising superior component **162** and inferior component **164**, shown in an unexpanded state. Superior component **162** is shown having input port **166**, operatively arranged for import of hardening material into the telescoping struts of the implant. Superior and inferior components **162** and **164** are telescopingly engageable. Superior component **162** comprises a body with a generally arcuate shape (quasi-elliptical cross-section), although implants of other shapes are certainly possible and intended to be within the scope of the appended claims. The body is shown as having at least one aperture **190**. Inferior component **164** also comprises a body with an arcuate shape, having at least one aperture **190**, and input port **166**. The inferior and superior components are of similar shapes and dimensions so as to be capable of matingly engaging one another. When expandable intervertebral fusion implant **100** is in the unexpanded state, superior component **162** and inferior component **164** form a hollow, substantially tubular structure having a cavity **191**.

FIG. 14B is a perspective view of expandable intervertebral fusion implant **100**, in an expanded state. Inferior component **164** further comprises a plurality of upwardly extending struts **170**, **171**, **172**, **173**, **174** and **175**. Superior component **162** further comprises a plurality of downwardly extending hollow channels **176**, **177**, **178**, **179**, **180** and **181** that receive, and telescopingly engage with, upwardly extending struts **170**, **171**, **172**, **173**, **174** and **175** respectively. The plurality of downwardly extending hollow channels **176**, **177**, **178**, **179**, **180** and **181** are also connected to input port **166**. Each hollow channel also includes a vent described infra.

FIG. 15A is a cross-sectional view of an expandable intervertebral fusion implant **100**, in an unexpanded state taken generally along line **15A-15A** in FIG. 14A. Superior component **162** further comprises channel **186** that connects the plurality of downwardly extending hollow channels **176**, **177**, **178**, **179**, **180** and **181**. Each of downwardly extending hollow channels **176**, **177**, **178**, **179**, **180** and **181** further comprises a retention shoulder operatively arranged to limit movement of the corresponding struts, and prevent the struts from exiting the channels. For example, channel **176** includes shoulder **187** to limit movement of strut **170**. Strut **170** includes flange **184** which abuts shoulder **187** when the implant is completely expanded. Similarly, channel **177** includes shoulder **188** to limit movement of strut **171**. Strut **171** includes flange **185** which abuts shoulder **188** when the implant is completely expanded.

FIG. 15B is a cross-sectional view of an expandable intervertebral fusion implant **100**, in an expanded state taken generally along line **15B-15B** in FIG. 14B. Hardenable material **189** is injected via input port **166**, filling the plurality of downwardly extending hollow channels **176**, **177**, **178**, **179**, **180** and **181**, as well as channel **186**. Injecting hardenable material **189** creates hydraulic pressure within the hollow channels and forces the plurality of upwardly extending struts **170**, **171**, **172**, **173**, **174** and **175** in a first direction D1, displacing superior component **162** in a first direction D1.

Each of the upwardly extending struts **170**, **171**, **172**, **173**, **174** and **175** further comprise a flange operatively arranged to limit movement of each strut within its respective channel. For example, as shown in FIG. 15B, flange **184** of strut **170** is shown abutting shoulder **187**, and flange **185** of strut **171** is shown abutting shoulder **188** when the implant is in a fully expanded state. In an unexpanded state, expandable intervertebral fusion implant **100** has a collapsed height  $h_1$

(as shown in FIG. 15A). As hardenable material **189** is introduced via port **166**, and evenly distributed to downwardly extending hollow channels **176**, **177**, **178**, **179**, **180** and **181** through channel **186**, upwardly extending struts **170**, **171**, **172**, **173**, **174** and **175** causing the displacement of superior component **162**, in a first direction D1. Downwardly extending hollow channels **176**, **177**, **178**, **179**, **180** and **181**, as well as channel **186** continue to fill with hardenable material **189**, until each flange abuts its respective shoulder, whereby the displacement of superior component **162** is stopped, resulting in expandable intervertebral fusion implant **100** having an expanded height  $h_2$  (as shown in FIG. 15B). The flanges and shoulder are thus arranged to prevent the struts from being expelled from the channels.

As hardenable material **189** is injected into downwardly extending hollow channels **176**, **177**, **178**, **179**, **180** and **181**, the air originally contained within the hollow channels as well as channel **186**, escapes via vents. Each channel has a vent, although only two of the six vents are shown for illustration in the drawings. For example, channels **176** and **177** each have a vent **182** and **183**, respectively. When expandable intervertebral fusion implant **100** is in an expanded state, having expanded height  $h_2$ , flange **184** is in contact with retention shoulder **187**, allowing hardenable material **189** to escape via vent **182**. When hardenable material **189** escapes vent **182** instead of air, this signals that the downwardly extending hollow channels **176**, **177**, **178**, **179**, **180** and **181**, have completely filled with hardenable material **189**. (The surgeon can actually see the hardenable material escaping through the vents with an endoscope.) When the surgeon sees the hardenable material escape through the vents, the surgeon is then free to cut injection tube **56** at input port **166**, remove the injection tube and let the hardenable material cure and harden, locking the implant in its expanded state. It should be understood that the vents within each respective hollow channel further contain a valve. For example, vent **182** further comprises valve **183** to allow control of the rate of escaping air and hydraulic pressure within the hollow channels. Hardenable material **189** is preferably made of poly(methyl methacrylate), polycarbonate resins, epoxy resins, polyamide resins, or equivalent. Superior component **162** and inferior component **164** of expandable intervertebral fusion implant **100** are preferably made of polyether ether ketone and titanium, or equivalent.

FIG. 16A is a perspective view of expandable intervertebral fusion implant **200**, in an unexpanded state having an intermediate telescoping struts **220**, **221**, **222**, **223**, **224** and **225**. Expandable intervertebral fusion implant **200** comprises superior component **262**, inferior component **264**, and input port **266**. Superior and inferior components **262** and **264** are telescopingly engageable. Superior component **262** comprises a body with a generally arcuate shape (quasi-elliptical cross-section), although implants of other shapes are certainly possible and intended to be within the scope of the appended claims. The body is shown as having at least one aperture **290**. Inferior component **264** comprises a body with an arcuate shape, having at least one aperture **286**, and input port **266**. The inferior and superior components are of similar shapes and dimensions so as to be capable of matingly engaging one another. When expandable intervertebral fusion implant **200** is in the unexpanded state, superior component **262** and inferior component **264** form a hollow, substantially tubular structure having a cavity **291**.

FIG. 16B is a perspective view of expandable intervertebral fusion implant **200**, in an unexpanded state having intermediate telescoping struts **220**, **221**, **222**, **223**, **224** and **225**. Superior component **262** further comprises a plurality

11

of downwardly extending struts 270, 271, 272, 273, 274 and 275. Inferior component 264 further comprises a plurality of upwardly extending hollow channels 276, 277, 278, 279, 280 and 281 that receive, and telescopingly engage with, intermediate telescoping struts 220, 221, 222, 223, 224 and 225 respectively. Intermediate telescoping struts 220, 221, 222, 223, 224 and 225 receive and telescopingly engage with downwardly extending struts 270, 271, 272, 273, 274 and 275 respectively. The plurality of upwardly extending hollow channels 276, 277, 278, 279, 280 and 281 are also connected to input port 266. Intermediate telescoping strut also includes a vent described infra.

FIG. 17A is a front view of an expandable intervertebral fusion implant 200, in an unexpanded state having intermediate telescoping struts 220, 221, 222, 223, 224 and 225.

FIG. 17B is a front view of an expandable intervertebral fusion implant 200, in an expanded state having intermediate telescoping struts 220, 221, 222, 223, 224 and 225. In this view only struts 220, 270, 221 and 271 are shown.

FIG. 18A a partial cross-sectional view of an expandable intervertebral fusion implant 200 in FIG. 17A, in an unexpanded state taken generally along line 18A-18A in FIG. 16A having intermediate telescoping struts 220, 221, 222, 223, 224 and 225. Inferior component 264 further comprises channel 286 that connects the plurality of upwardly extending hollow channels 276, 277, 278, 279, 280 and 281. Each of upwardly extending hollow channels 276, 277, 278, 279, 280 and 281 further comprises intermediate telescoping struts 220, 221, 222, 223, 224 and 225, respectively. Each intermediate telescoping strut 220, 221, 222, 223, 224 and 225 further comprises an intermediate retention shoulder, an intermediate flange, and a vent respectively. (Only one of the six intermediate retention shoulders, 228, one of the six intermediate flanges, 226, and one of the vents, 282, are shown in the drawings.)

FIG. 18B is a partial cross-sectional view of an expandable intervertebral fusion implant 200 in FIG. 17B, in an expanded state taken generally along line 18B-18B in FIG. 16B. Hardenable material 289 is injected via input port 266, filling the plurality of upwardly extending hollow channels 276, 277, 278, 279, 280 and 281, as well as channel 286. Injecting hardenable material 289 creates hydraulic pressure within the hollow channels and forces the plurality of downwardly extending struts 270, 271, 272, 273, 274 and 275 in a first direction D1, displacing superior component 262 in a first direction D1.

Each of downwardly extending struts 270, 271, 272, 273, 274 and 275 further comprises a flange operatively arranged to limit movement of each intermediate strut within its respective channel. For example, as shown in FIG. 18B, flange 284 is shown abutting intermediate flange 227 when expandable intervertebral fusion implant 200 is in a fully expanded state. As hardenable material 289 is introduced via port 266, and evenly distributed to upwardly extending hollow channels 276, 277, 278, 279, 280 and 281, as well as, intermediate telescoping struts 220, 221, 222, 223, 224 and 225 through channel 286, downwardly extending struts 270, 271, 272, 273, 274 and 275, as well as, intermediate telescoping struts 220, 221, 222, 223, 224 and 225 are displaced in a first direction D1, displacing superior component 262, in a first direction D1. The upwardly extending hollow channels 276, 277, 278, 279, 280 and 281, intermediate telescoping struts 220, 221, 222, 223, 224 and 225, and channel 286 continue to fill with hardenable material 289, until each flange of each the downwardly extending struts 270, 271, 272, 273, 274 and 275 contact each respective intermediate retention shoulder of each of intermediate

12

telescoping struts 220, 221, 222, 223, 224 and 225; and, each intermediate flange contacts each retention shoulder of each of the upwardly extending hollow channels 276, 277, 278, 279, 280 and 281, whereby the displacement of superior component 162 in direction D1 is stopped. The flanges and intermediate retention shoulders abut, and the intermediate flanges and shoulders abut, and are thus arranged to prevent the struts and the intermediate struts from being expelled from the channels.

As hardenable material 289 is injected into upwardly extending hollow channels 276, 277, 278, 279, 280 and 281, the air originally contained within the hollow channels, the intermediate telescoping struts, and channel 286, escapes via vents. Each intermediate strut has a vent, although only two of the six vents are shown for illustration in the drawings. For example, intermediate struts 220 and 221 each have a vent 282 and 283 respectively. When expandable intervertebral fusion implant 200 is in an expanded state, flange 284 is in contact with intermediate retention shoulder 227, allowing hardenable material 289 to escape via vent 282. When hardenable material 289 escapes vent 282 instead of air, this signals that the upwardly extending hollow channels 276, 277, 278, 279, 280 and 281, and the intermediate telescoping struts 220, 221, 222, 223, 224 and 225 have completely filled with hardenable material 80. (The surgeon can actually see the hardenable material escaping through the vents with an endoscope.) When the surgeon sees the hardenable material escape through the vents, the surgeon is then free to cut injection tube 56 at input port 266, remove the injection tube, and let the hardenable material cure and harden, locking the implant in its expanded state. It should be understood that the vents within each respective intermediate strut further contain a valve. For example, vent 282 further comprises valve 283 to allow control of the rate of escaping air and hydraulic pressure within the hollow channels and intermediate struts. Hardenable material 289 is preferably made of poly(methyl methacrylate), polycarbonate resins, epoxy resins, polyamide resins, or equivalent. Superior component 262 and inferior component 264 of expandable intervertebral fusion implant 200 are preferably made of polyether ether ketone and titanium, or equivalent.

FIGS. 19A and 19B are perspective views of expandable intervertebral fusion implant 300, in an unexpanded and an expanded state respectively. Expandable intervertebral fusion implant 300 comprises a plurality of first intermediate telescoping struts 320, 321, 322, 324, 324 and 325, and a plurality of second intermediate telescoping struts 330 331, 332, 333, 334, and 335. Expandable intervertebral fusion implant 300 further comprises superior component 362, inferior component 364, and input port 366. Superior and inferior components 362 and 364 are telescopingly engagable. Superior component 362 comprises a body with a generally arcuate shape (quasi-elliptical cross-section), although implants of other shapes are certainly possible and intended to be within the scope of the appended claims. The body is shown as having at least one aperture 190. Inferior component 364 also comprises a body with an arcuate shape, having at least one aperture 390 and input port 366. The inferior and superior components are of similar shapes and dimensions so as to be capable of matingly engaging one another. When expandable intervertebral fusion implant 300 is in the unexpanded state, superior component 362 and inferior component 364 form a hollow, substantially tubular structure having a cavity 388.

Superior component 362 further comprises a plurality of downwardly extending struts 370, 371, 372, 373, 374 and 375. Inferior component 364 further comprises a plurality of



upwardly extending hollow channels **376, 377, 378, 379, 380** and **381**; a plurality of first intermediate telescoping struts **320, 321, 322, 323, 324** and **325**; and, a plurality of second intermediate telescoping struts **330, 331, 332, 333, 334** and **335**. The plurality of upwardly extending hollow channels **376, 377, 378, 379, 380** and **381** receive, and telescopingly engage, the plurality of first intermediate telescoping struts **320, 321, 322, 323, 324** and **325** respectively. The plurality of first intermediate telescoping struts **320, 321, 322, 323, 324** and **325** receive, and telescopingly engage, the plurality of second intermediate telescoping struts **330, 331, 332, 333, 334** and **335** respectively. The plurality of second intermediate telescoping struts **330, 331, 332, 333, 334** and **335** receive, and telescopingly engages, downwardly extending struts **370, 371, 372, 373, 374** and **375**, respectively. The plurality of upwardly extending hollow channels **376, 377, 378, 379, 380** and **381** are also connected to input port **366**.

It should be appreciated that the present embodiment as claimed is not limited to struts comprising only two telescoping members. For example, the expandable intervertebral fusion implant may comprise a third intermediate telescoping member arranged to telescopingly engage the second intermediate telescoping member, although this is not shown in the drawings. The embodiment could have even more than three telescoping members.

FIG. 20A is a front view of an expandable intervertebral fusion implant, in an unexpanded state having a first intermediate telescoping strut and a second intermediate telescoping strut

FIG. 20B is a front view of an expandable intervertebral fusion implant, in an expanded state having a first intermediate telescoping strut and a second intermediate telescoping strut

FIG. 21A is a partial cross-sectional view of expandable intervertebral fusion implant **300** in FIG. 20B, in an unexpanded state taken generally along line **21A-21A** in FIG. 19A having a plurality of first intermediate telescoping struts **320, 321, 322, 323, 324** and **325** and a plurality of second intermediate telescoping struts **330, 331, 332, 333, 334** and **335**. Inferior component **364** further comprises channel **386** that connects the plurality of upwardly extending hollow channels **376, 377, 378, 379, 380** and **381**. Upwardly extending hollow channels **376, 377, 378, 379, 380** and **381** further comprise a plurality of first intermediate telescoping struts **320, 321, 322, 323, 324** and **325** and a plurality of second intermediate telescoping struts **330, 331, 332, 333, 334** and **335**, as well as, retention shoulder **387**. Each of the plurality of first intermediate telescoping struts **320, 321, 322, 323, 324** and **325** further comprise a first intermediate flange, and a first intermediate retention shoulder. (Only one of the six first intermediate retention shoulders, **228**, and one of the six intermediate flanges, **326**, are shown in the drawings.) Each of the plurality of second intermediate telescoping struts **330, 331, 332, 333, 334** and **335** further comprise a second intermediate flange, a second intermediate retention shoulder, and a vent. (Only one of the six intermediate retention shoulders, **328**, one of the six intermediate flanges, **326**, and one of the six vents **382** are shown in the drawings.)

FIG. 21B is a partial cross-sectional view of expandable intervertebral fusion implant **300** in FIG. 20B, in an expanded state taken generally along line **21B-21B** in FIG. 19B. Hardenable material **389** is injected via input port **366**, filling the plurality of upwardly extending hollow channels **376, 377, 378, 379, 380** and **381**, as well as channel **386**. Injecting hardenable material **389** creates hydraulic pressure within the hollow channels and forces the plurality of

downwardly extending struts **370, 371, 372, 373, 374** and **375**; the plurality of first intermediate telescoping struts **320, 321, 322, 323, 324** and **325**; and, the plurality of second intermediate telescoping struts **330, 331, 332, 333, 334** and **335** in a first direction **D1**, displacing superior component **362** in a first direction **D1**.

Each of the downwardly extending struts **370, 371, 372, 373, 374** and **375** further comprises a flange operatively arranged to limit movement of each of the second plurality of intermediate struts within its respective channel. As hardenable material **389** is introduced via port **366**, and evenly distributed to upwardly extending hollow channels **376, 377, 378, 379, 380** and **381**, the plurality of first intermediate telescoping struts **320, 321, 322, 323, 324** and **325**; and, the plurality of second intermediate telescoping struts **330, 331, 332, 333, 334** and **335** through channel **386**, the downwardly extending struts **370, 371, 372, 373, 374** and **375**, the plurality of first intermediate telescoping struts **320, 321, 322, 323, 324** and **325**, and the plurality of second intermediate telescoping struts **330, 331, 332, 333, 334** and **335**, are displaced in a first direction **D1**, displacing superior component **362**, in a first direction **D1**. Upwardly extending hollow channels **376, 377, 378, 379, 380** and **381**, the plurality of first intermediate telescoping struts **320, 321, 322, 323, 324** and **325**, and the plurality of second intermediate telescoping struts **330, 331, 332, 333, 334** and **335**, as well as, channel **386** continue to fill with hardenable material **389** until each flange of each of the downwardly extending struts **370, 371, 372, 373, 374** and **375** contact each respective second intermediate shoulder of each of the second plurality of intermediate telescoping struts **330, 331, 332, 333, 334** and **335**; and each respective second intermediate flange contacts each respective first intermediate retention shoulder; and, each respective first intermediate flange contacts each respective shoulder of each of the upwardly extending hollow channels **376, 377, 378, 379, 380** and **381**, stopping the displacement of superior component **362** in a first direction **D1**.

As hardenable material **389** is injected into upwardly extending hollow channels **376, 377, 378, 379, 380** and **381**, the air originally contained within the hollow channels, the plurality of first intermediate telescoping struts, the plurality of second intermediate telescoping struts, and channel **386**, escapes via vents. Each of the plurality of second intermediate struts **330, 331, 332, 333, 334** and **335** has a vent, although only one of the six vents are shown for illustration in the drawings. For example, second intermediate strut **330** has a vent **382** as shown in FIGS. 21A and 21B. When expandable intervertebral fusion implant **300** is in an expanded state, flange **384** is in contact with second intermediate retention shoulder **338**, allowing hardenable material **389** to escape via vent **382**. When hardenable material **389** escapes vent **382** instead of air, this signals that the upwardly extending hollow channels **376, 377, 378, 379, 380** and **381**, the plurality of first intermediate telescoping struts **320, 321, 322, 323, 324** and **325**, and the plurality of second intermediate telescoping struts **330, 331, 332, 333, 334** and **335**, and channel **386** have completely filled with hardenable material **389**. (The surgeon can actually see the hardenable material escaping through the vents with an endoscope.) When the surgeon sees the hardenable material escape through the vents, the surgeon is then free to cut injection tube **56** at input port **366**, remove the injection tube, and let the hardenable material cure and harden, locking the implant in its expanded state. It should be understood that the vents within each respective second intermediate strut further contain a valve. For example, vent

**382** further comprises valve **383** to allow control of the rate of escaping air and hydraulic pressure within the hollow channels, the first and second intermediate struts. Hardenable material **289** is preferably made of poly(methyl methacrylate), polycarbonate resins, epoxy resins, polyamide resins, or equivalent. Superior component **362** and inferior component **364** of expandable intervertebral fusion implant **300** are preferably made of polyether ether ketone and titanium, or equivalent.

FIG. 22A is a side view of a hingedly expandable intervertebral fusion implant **400**, in an unexpanded state. Hingedly expandable intervertebral fusion implant **400** broadly comprises a superior component **462**, an inferior component **464**, a hinge **408**, an input port **466**, and a vent **482**.

FIGS. 22B and 22C are front views of hingedly expandable intervertebral fusion implant **400**, in an unexpanded and expanded state respectively.

FIG. 22D is a cross-sectional view of hingedly expandable intervertebral fusion implant **400** as shown in FIG. 22A, in an unexpanded state taken generally along line 22D-22D in FIG. 22B. Superior component **462** further comprises downwardly extending strut **470**. Downwardly extending strut **470** further comprises a flange **484**. Inferior component **464** further comprises an upwardly extending hollow channel **476**. Upwardly extending hollow channel further comprises a shoulder **487**. Input port **466** is operatively arranged to deliver a hardenable material **489** into upwardly extending hollow channel **476**. Vent **482** is operatively arranged to allow air to escape from the upwardly extending hollow channel **476** as hardenable material **489** is added to channel **476**.

FIG. 22E is a cross-sectional view of hingedly expandable intervertebral fusion implant **400** in FIG. 22A, in an expanded state taken generally along line 22E-22E in FIG. 22C. As hardenable material **489** is injected, via input port **466**, into upwardly extending hollow channel **476**, hydraulic pressure is created within upwardly extending hollow channel **476**, displacing downwardly extending strut **470** in a first direction D1. As downwardly extending strut **470** is displaced in first direction D1, superior component **462** is rotationally displaced about axis of rotation AR. Hardenable material **489** is injected until flange **484** of downwardly extending strut **470** abuts shoulder **487** of upwardly extending hollow channel **476**. When hardenable material **489** escapes vent **482** instead of air, this signals that channel **476** has completely filled with hardenable material. (The surgeon can actually see the hardenable material escaping through the vents with an endoscope.) When the surgeon sees the hardenable material escape through the vents, the surgeon is then free to cut injection tube **56** at input port **466**, remove the injection tube, and let the hardenable material cure and harden, locking the implant in its expanded state. Vent **482** further comprises valve **492** to allow control of the rate of escaping air and hydraulic pressure within the hollow channel. Hardenable material **489** is preferably made of poly(methyl methacrylate), polycarbonate resins, epoxy resins, polyamide resins, or equivalent. Superior component **462** and inferior component **464** of expandable intervertebral fusion implant **400** are preferably made of polyether ether ketone and titanium, or equivalent.

FIG. 22F is a perspective view of hingedly expandable intervertebral fusion implant **400**, in an expanded state. Superior component **462** and inferior component **464** are shown as having at least one aperture **490** to accept bone fusing material.

FIG. 23A illustrates hingedly expandable intervertebral fusion implant **400** in place in disc space  $D_{L3-L4}$  in an

unexpanded state. As illustrated in FIG. 23A, hingedly expandable intervertebral fusion implant **400** can be placed within disc space  $D_{L3-L4}$  where vertebrae L3 and vertebrae L4 as misaligned.

FIG. 23B illustrates hingedly expandable intervertebral fusion implant **400** in place in disc space  $D_{L3-L4}$ , in an expanded state. As superior component **462** is rotationally displaced about axis of rotation AR, vertebrae L3 is displaced in direction D1, correcting misalignment between vertebra L3 and L4. This alignment correcting procedure could be used to correct spinal misalignment in patients with scoliosis.

FIG. 24 is a perspective view of a bilaterally expandable intervertebral fusion implant **500**, in an unexpanded state. Bilaterally expandable intervertebral fusion implant **500** comprises a first superior component **562**, a second superior component **563**, a first inferior component **564**, and a second inferior component **565**. First and second superior components **562** and **563** further comprise a toothed surface **512**, and first and second inferior components **564** and **565** further comprise a toothed surface **513**. Toothed surfaces **512** and **513** prevent bilaterally expandable intervertebral fusion implant **500** from shifting within a disc space. It should be appreciated that although toothed surfaces **512** and **513** are shown as having a toothed texture in FIGS. 24-28, any equivalent texture that will produce a sufficient static coefficient of friction between the superior components of the implant and the respective vertebra the implant is placed between, that prevents bilaterally expandable intervertebral fusion implant **500** from slipping laterally within the disc space could be utilized. Bilateral expandable intervertebral fusion implant **500** has a proximate end **509** and a distal end **510**. First inferior component **564** comprises upwardly extending hollow channel **576** and vent **582**. Second inferior component **565** further comprises upwardly extending hollow channel **577** and input port **566**. First and second inferior components **564** and **565** contain upwardly extending hollow channels **576** and **577** respectively, to allow for the dispersion of a hardenable material **589** throughout the first and second inferior components. In its unexpanded state, the superior components and inferior components form an aperture **590**, to receive bone fusing material.

FIG. 25 is a perspective view of bilaterally expandable intervertebral fusion implant **500**, in an expanded state. First superior component **562** further comprises a downwardly extending strut wall **570**. Second superior component **563** further comprises a downwardly extending strut wall **571**. Upwardly extending hollow channel **576** is arranged to receive and telescopingly engage with downwardly extending strut wall **570**. Upwardly extending hollow channel **577** is arranged to receive and telescopingly engage with downwardly extending strut wall **571**. Each of upwardly extending hollow channels **576** and **577** further comprise a shoulder **587** and **588** respectively (as shown in FIG. 28).

First and second superior components **562** and **563** further comprise a first superior horizontal telescoping strut **526** and a second superior horizontal telescoping strut **527**. As shown in FIG. 25, first superior horizontal telescoping strut **526** is arranged at the proximate end **509** of implant **500** and second superior horizontal telescoping strut **527** is arranged at the distal end **510** of implant **500**. First and second inferior components **564** and **565** further comprise a first inferior horizontal telescoping strut **528** and a second inferior horizontal telescoping strut **529**. First superior horizontal telescoping strut **528** is arranged at the proximate end **509** of

implant **500** and second superior horizontal telescoping strut **529** is arranged at the distal end **510** of implant **500**.

FIG. **26A** is a side view of bilaterally expandable intervertebral fusion implant **500**, in an expanded state.

FIG. **26B** is an opposite side view of a bilaterally expandable intervertebral fusion implant **500**, in an expanded state.

FIG. **27** is a front view of bilaterally expandable intervertebral fusion implant **500**, in an expanded state.

FIG. **28** is a cross-sectional view of bilaterally expandable intervertebral fusion implant **500**, in an expanded state taken generally along line **28-28** in FIG. **25**. Upwardly extending hollow channels **576** and **577** as well as first and second inferior horizontal telescoping struts **527** and **528** are operatively arranged to receive and fill with hardenable material **589**, injected via port **566**. It should be appreciated that the present embodiment is positioned, vertically expanded, and horizontally expanded to the desirable dimensions manually, that is to say, not using hardenable material **589** to exert hydraulic pressure upon downwardly extending strut walls **570** and **571**. However, it should also be appreciated that the present embodiment could be vertically and horizontally expanded using hydraulic pressure created by injecting hardenable material **589** into upwardly extending hollow channels **576** and **577**.

Downwardly extending strut walls **570** and **571** each have a flange, **584** and **585** respectively, that are operatively arranged to limit movement of each downwardly extending strut wall within its respective upwardly extending hollow channel. For example, as shown in FIG. **28**, Flange **584** of strut wall **570** is shown abutting shoulder **587** when the implant **500** is in a fully expanded state. As hardenable material is injected via port **566** into upwardly extending hollow channels **576** and **577** as well as first and second inferior horizontal telescoping struts **528** and **529**, the surgeon could continue to hold the desired position of implant **500**, or allow the implant to expand due to hydraulic pressure to its fully expanded state.

FIG. **29** is a cross-sectional view of bilaterally expandable intervertebral fusion implant **500**, in an unexpanded state taken generally along line **29-29** in FIG. **24**. First and second inferior horizontal telescoping struts **528** and **529** further comprise first inferior horizontal flange **530** and a second inferior horizontal flange **531** respectively. First inferior component **564** further comprises a first inferior horizontal shoulder **540** and a second inferior horizontal shoulder **541** respectively, and operatively arranged to limit the horizontal movement of first and second inferior horizontal telescoping struts **528** and **529** respectively. First and second superior horizontal telescoping struts **526** and **527** function similarly, although they are not shown in the drawings.

FIG. **30** is a cross-sectional view of bilaterally expandable intervertebral fusion implant **500**, in an expanded state taken generally along line **30-30** in FIG. **26A**; and,

FIG. **31** is a cross-sectional view of bilaterally expandable intervertebral fusion implant **500**, in an expanded state taken along line **31-31** in FIG. **26A**. This figure illustrates hardenable material **589** filling upwardly extending hollow channels **576** and **577** as well as first and second inferior horizontal struts **528** and **529**. When hardenable material **589** escapes vent **582** instead of air, this signals that channels **576** and **577** and horizontal struts **528** and **529** are completely filled with hardenable material. (The surgeon can actually see the hardenable material escaping through the vent with an endoscope.) When the surgeon sees the hardenable material escape through the vent, the surgeon is then free to cut injection tube **56** at input port **566**, remove the injection tube, and let the hardenable material cure and

harden, locking the implant in its expanded state. Vent **582** further comprises valve **592** to allow control of the rate of escaping air and hydraulic pressure within the hollow channel. Hardenable material **589** is preferably made of poly (methyl methacrylate), polycarbonate resins, epoxy resins, polyamide resins, or equivalent. Superior components **562** and **563**, as well as, and inferior components **564** and **565** of expandable intervertebral fusion implant **500** are preferably made of polyether ether ketone and titanium, or equivalent.

It should be appreciated that hardenable materials **89**, **189**, **289**, **389**, **489** and **589** are intended to be injected into ports **66**, **166**, **266**, **366**, **466**, and **566** using a hydraulic pump or other suitable means for injecting material through injection tube **56**. It should be further understood that the expandable intervertebral implants described herein are applicable to all generally accepted surgical approaches, including microsurgical and endoscopic applications.

Thus it is seen that the objects of the invention are efficiently obtained, although changes and modifications to the invention should be readily apparent to those having ordinary skill in the art, which changes would not depart from the spirit and scope of the invention as claimed.

LIST OF REFERENCE NUMBERS

- 10** Spinal column
- C1-C7 Cervical vertebrae
- T1-T9 Thoracic vertebrae
- L1-L5 Lumbar vertebrae
- S Sacrum
- C Coccyx
- D1 Direction
- D2 Direction
- D3 Direction
- D<sub>L1-L2</sub> Disc
- D<sub>L2-L3</sub> Disc
- D<sub>L3-L4</sub> Disc
- D<sub>L4-L5</sub> Disc
- F Facet
- FJ Facet joint
- h<sub>1</sub> Collapsed height
- h<sub>2</sub> Expanded height
- SP Spinous process
- TP Transverse process
- IF Intervertebral foramen
- A Annulus
- AR Axis of rotation
- N Nucleus
- 50** Distractor
- 52** Means of attachment
- 54** Disk Space
- 56** Injection tube
- 58** Upper spacer
- 59** Lower spacer
- 60** Expandable intervertebral fusion implant
- 62** Superior component
- 64** Inferior component
- 66** Input port
- 70** Downwardly extending strut
- 71** Downwardly extending strut
- 72** Downwardly extending strut
- 73** Downwardly extending strut
- 74** Downwardly extending strut
- 75** Downwardly extending strut
- 76** Upwardly extending hollow channel
- 77** Upwardly extending hollow channel
- 78** Upwardly extending hollow channel

## 19

79 Upwardly extending hollow channel  
 80 Upwardly extending hollow channel  
 81 Upwardly extending hollow channel  
 82 Vent  
 83 Vent  
 84 Flange  
 85 Flange  
 86 Channel  
 87 Shoulder  
 88 Shoulder  
 89 Hardenable material  
 90 Aperture  
 91 Cavity  
 92 Valve  
 93 Valve  
 100 Expandable intervertebral fusion implant  
 162 Superior component  
 164 Inferior component  
 166 Input port  
 170 Upwardly extending strut  
 171 Upwardly extending strut  
 172 Upwardly extending strut  
 173 Upwardly extending strut  
 174 Upwardly extending strut  
 175 Upwardly extending strut  
 176 Downwardly extending hollow channel  
 177 Downwardly extending hollow channel  
 178 Downwardly extending hollow channel  
 179 Downwardly extending hollow channel  
 180 Downwardly extending hollow channel  
 181 Downwardly extending hollow channel  
 182 Vent  
 183 Vent  
 184 Flange  
 185 Flange  
 186 Channel  
 187 Shoulder  
 188 Shoulder  
 189 Hardenable material  
 190 Aperture  
 191 Cavity  
 192 Valve  
 193 Valve  
 200 Expandable intervertebral fusion implant  
 220 Intermediate telescoping strut  
 221 Intermediate telescoping strut  
 222 Intermediate telescoping strut  
 223 Intermediate telescoping strut  
 224 Intermediate telescoping strut  
 225 Intermediate telescoping strut  
 226 Intermediate flange  
 227 Intermediate flange  
 228 Intermediate retention shoulder  
 229 Intermediate retention shoulder  
 262 Superior component  
 264 Inferior component  
 266 Input port  
 270 Downwardly extending strut  
 271 Downwardly extending strut  
 272 Downwardly extending strut  
 273 Downwardly extending strut  
 274 Downwardly extending strut  
 275 Downwardly extending strut  
 276 Upward extending hollow channel  
 277 Upward extending hollow channel  
 278 Upward extending hollow channel  
 279 Upward extending hollow channel

## 20

280 Upward extending hollow channel  
 281 Upward extending hollow channel  
 282 Vent  
 283 Vent  
 5 284 Flange  
 285 Flange  
 286 Channel  
 287 Shoulder  
 288 Shoulder  
 10 289 Hardenable material  
 290 Aperture  
 291 Cavity  
 292 Valve  
 293 Valve  
 15 300 Expandable intervertebral fusion implant  
 320 First intermediate telescoping strut  
 321 First intermediate telescoping strut  
 322 First intermediate telescoping strut  
 323 First intermediate telescoping strut  
 20 324 First intermediate telescoping strut  
 325 First intermediate telescoping strut  
 326 First intermediate flange  
 327 First intermediate flange  
 328 First intermediate retention shoulder  
 25 329 First intermediate retention shoulder  
 330 Second intermediate telescoping strut  
 331 Second intermediate telescoping strut  
 332 Second intermediate telescoping strut  
 333 Second intermediate telescoping strut  
 30 334 Second intermediate telescoping strut  
 335 Second intermediate telescoping strut  
 336 Second intermediate flange  
 337 Second intermediate flange  
 338 Second intermediate retention shoulder  
 35 339 Second intermediate retention shoulder  
 362 Superior component  
 364 Inferior component  
 366 Input port  
 370 Downwardly extending strut  
 40 371 Downwardly extending strut  
 372 Downwardly extending strut  
 373 Downwardly extending strut  
 374 Downwardly extending strut  
 375 Downwardly extending strut  
 45 376 Upward extending hollow channel  
 377 Upward extending hollow channel  
 378 Upward extending hollow channel  
 379 Upward extending hollow channel  
 380 Upward extending hollow channel  
 50 381 Upward extending hollow channel  
 382 Vent  
 383 Vent  
 384 Flange  
 385 Flange  
 55 386 Channel  
 387 Shoulder  
 388 Shoulder  
 389 Hardenable material  
 390 Aperture  
 60 391 Cavity  
 392 Valve  
 393 Valve  
 400 Expandable intervertebral fusion implant  
 408 Hinge  
 65 462 Superior component  
 464 Inferior component  
 466 Input port

- 470 Downwardly extending strut
- 476 Upward extending hollow channel
- 482 Vent
- 484 Flange
- 487 Retention shoulder
- 490 Aperture
- 492 Valve
- 500 Expandable intervertebral fusion implant
- 509 Proximate end
- 510 Distal end
- 512 Superior toothed surface
- 513 Inferior toothed surface
- 526 First superior horizontal telescoping strut
- 527 Second superior horizontal telescoping strut
- 528 First inferior horizontal telescoping strut
- 529 Second inferior horizontal telescoping strut
- 562 First superior component
- 563 Second superior component
- 564 First inferior component
- 565 Second inferior component
- 566 Input port
- 570 Downwardly extending strut wall
- 571 Downwardly extending strut wall
- 576 Upwardly extending hollow channel
- 577 Upwardly extending hollow channel
- 582 Vent
- 584 Flange
- 585 Flange
- 586 Channel
- 587 Shoulder
- 588 Shoulder
- 589 Hardenable material
- 590 Aperture
- 592 Valve

I claim:

1. An expandable intervertebral fusion implant, comprising:
  - an inferior component;
  - a superior component telescopingly engageable with the inferior component; and,
  - an input port arranged in the inferior or the superior component;
 wherein:
  - the inferior component or the superior component includes a vent; and,
  - when a first material is introduced through the input port and into the inferior or the superior component, the superior component is displaced in a first direction relative to the inferior component.
2. The expandable intervertebral fusion implant of claim 1, wherein the inferior component comprises a first upwardly extending hollow channel and the superior component comprises a first downwardly extending strut arranged to telescopingly engage the first upwardly extending hollow channel.
3. The expandable intervertebral fusion implant of claim 1, wherein the superior component comprises a first downwardly extending hollow channel and the inferior component comprises a first upwardly extending strut arranged to telescopingly engage the first upwardly extending hollow channel.
4. The expandable intervertebral fusion implant of claim 1, wherein the inferior and superior components are expandable in a second direction, different than the first direction.

5. The expandable intervertebral fusion implant of claim 4, wherein the inferior and superior components are expandable in a third direction, different than the first and second directions.
6. The expandable intervertebral fusion implant of claim 1, further comprising:
  - a first hollow channel;
  - a second hollow channel connected to the first hollow channel by a further hollow channel;
  - a first strut arranged to telescopingly engage the first hollow channel; and,
  - a second strut arranged to telescopingly engage the second hollow channel;
 wherein the first, second, and further hollow channels are arranged to receive the first material.
7. The expandable intervertebral fusion implant of claim 1, further comprising a cavity formed between the inferior and superior components to receive bone fusing material.
8. The expandable intervertebral fusion implant recited in claim 1, wherein said inferior component comprises a body, and said body comprises at least one aperture therein.
9. The expandable intervertebral fusion implant recited in claim 1, wherein said superior component comprises a body, and said body comprises at least one aperture therein.
10. The expandable intervertebral fusion implant recited in claim 1, wherein said inferior component comprises a body, and said body is arcuate in shape.
11. The expandable intervertebral fusion implant recited in claim 1, wherein said superior component comprises a body, and said body is arcuate in shape.
12. The expandable intervertebral fusion implant recited in claim 1, further comprising:
  - a hollow channel including a shoulder, the hollow channel connected to the input port; and,
  - a strut arranged to telescopingly engage the hollow channel, the strut including a flange arranged to slide within the hollow channel, and abut the shoulder when the superior component is in a maximally extended position relative to the inferior component.
13. The expandable intervertebral fusion implant recited in claim 1, wherein the superior and inferior components are hingedly connected.
14. The expandable intervertebral fusion implant recited in claim 1, further comprising a first intermediate telescoping member arranged to telescopingly engage the inferior and superior components.
15. The expandable intervertebral fusion implant recited in claim 14, further comprising a second intermediate telescoping member arranged to telescopingly engage the first intermediate telescoping member.
16. The expandable intervertebral fusion implant of claim 1, wherein the vent comprises a valve.
17. An expandable intervertebral fusion implant having a proximal end and a distal end, the expandable intervertebral fusion implant comprising:
  - an inferior component;
  - a superior component arranged to telescopingly engage the inferior component; and,
  - an input port and a vent arranged within the inferior component or the superior component;
 wherein when the superior component is expanded to a first position relative to the inferior component, a first material is introduced into and through the inferior component and/or the superior component to maintain the position of the superior and inferior components.

18. The expandable intervertebral fusion implant of claim 17, further comprising a hollow channel extending between the input port and the vent, the hollow channel within the inferior component.

19. The expandable intervertebral fusion implant of claim 17, further comprising a hollow channel extending between the input port and the vent, the hollow channel within the superior component.

20. The expandable intervertebral fusion implant of claim 17, wherein the vent comprises a valve.

\* \* \* \* \*